

# Aftermarket Interface Module™

Combined High Idle with  
Upfitter Interface Module® Technology

## Overview

- Passive CAN data acquisition
- High idle with park brake trigger (optional charge protect feature)
- Outputs can be programmed as momentary, latching, time-hold, time-delay or flashing
- Able to unlock doors via the OBDII interface
- Simple plug and play connection for CAN data
- Provides access to Electric Park Brake signal for the 2023 Ford Super Duty®

## Features

- FLEXIBLE DESIGN: Saves time, cost and additional components; user interface makes programming output functions easy
- Multiple inputs can control a single output
- Eight high/low true outputs and two inputs
- Works with Ford, GM and RAM vehicle CAN, plus J1939 to provide real-time chassis data
- Warning LEDs offer easy troubleshooting
- Includes Intermittent Fault Filter™ (IFF) technology to eliminate false readings



# Details

Product features may vary by make, model or year. See instructions for complete details.

## EXAMPLE SCHEMATIC

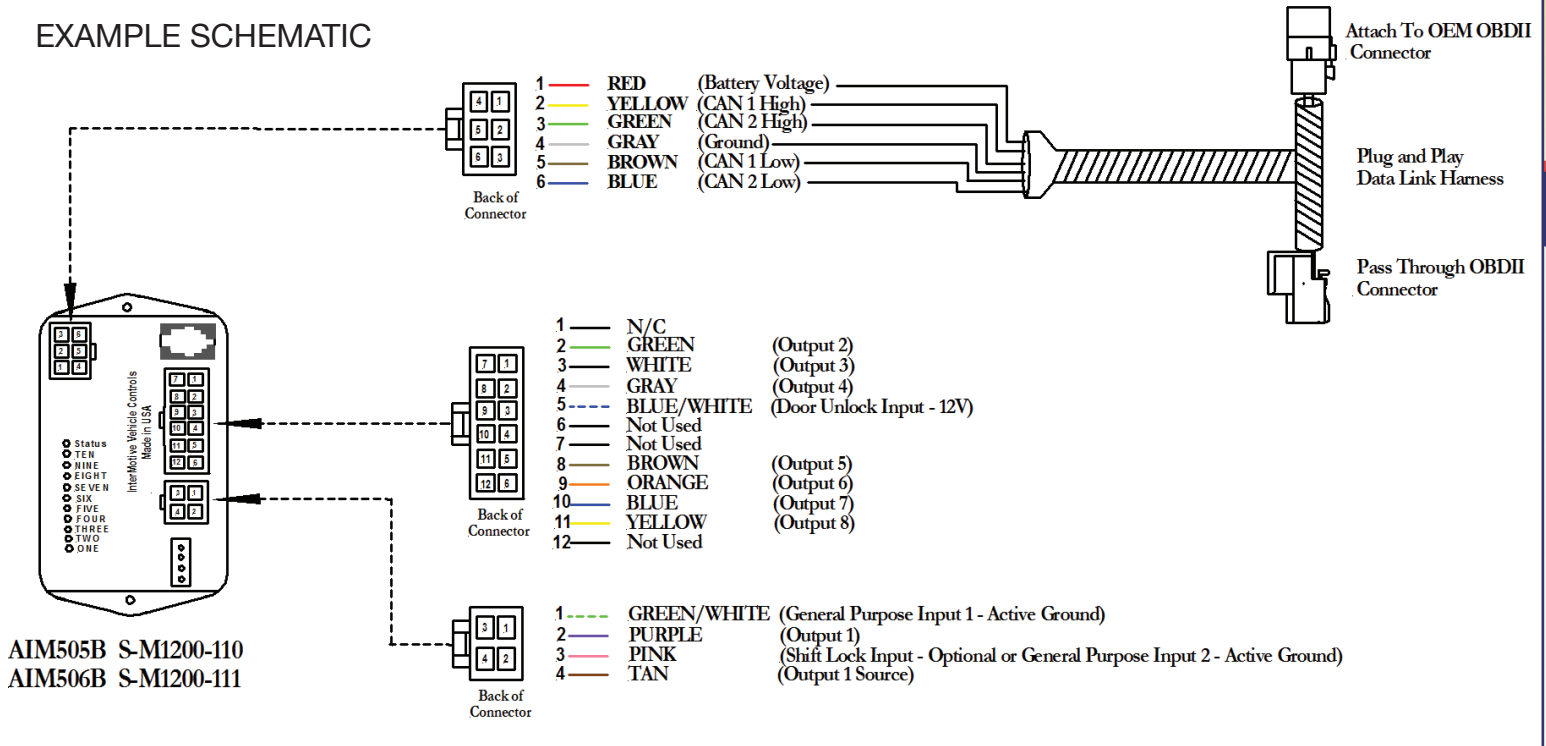

## SPECIFICATIONS

Number of Inputs	Two
Number of Outputs	Eight
Current Draw	150 mA
Quiescent Draw	< 2 mA (sleep current)
CAN Speed	High and medium speed
Temperature Range	-40°C to 80°C
Dimensions	4" L x 2" W x 1" H

## AVAILABLE DATA INCLUDES: (partial list)

- **Transmission:** Range | Fluid Temperature
- **Lights:** External Lights\* | High and Low Beams | Turn Signals
- **Doors:** Lock | Unlock
- **Brakes:** ABS Event | Park Brake and Electric Park Brake | Service Brakes
- **Other:** Vehicle Speed | Seatbelt
- **Engine/Fuel:** Clean Tach Output | Check Engine Light (MIL)\*\* | Coolant and Oil Temp.† | RPM | Engine Running | Ignition Switch Status | Fuel Level | Intake Air Temp. | Throttle Position | Vbat | VSS (2.2 Hz/mph)

\* Daytime running lights only work with Ford vehicles

\*\* Check Engine Light Output does not work with RAM vehicles

† Oil Temperature only works with Ford vehicles