

ILISC301-A Wheelchair Lift Shift Interlock—Manual Lift Door 2012—2019 Nissan NV Full Size Van

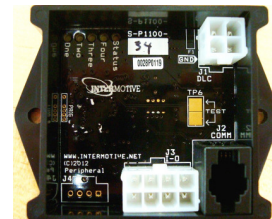

Introduction

The ILISC301-A is a wheel chair lift interlock intended for commercial use with a Nissan NV full size van. It can be configured to use either the manual side or rear doors, and will operate with the ignition key on or off. The transmission shifter will lock in Park when the designated lift door is open or when the Park Brake is set. The lift will not be powered until all the safety conditions are met: Transmission in Park, Park Brake set, Lift Door open, etc.

ILISC301 Add-On Option

ILISC301-AD—Door Ajar: monitors an additional door other than lift door.

Installation Instructions

Disconnect vehicle battery before proceeding with installation.



WARNING
Disconnect the battery to prevent setting a check engine light.

IMPORTANT—READ BEFORE INSTALLATION

It is the installer's responsibility to route and secure all wiring harnesses where they cannot be damaged by sharp objects, mechanical moving parts and high heat sources. Failure to do so could result in damage to the system or vehicle and create possible safety concerns for the operator and passengers. Avoid placing the module where it could encounter strong magnetic fields from high current cabling connected to motors, solenoids, etc. Avoid radio frequency energy from antennas or inverters next to the module. Avoid high voltage spikes in vehicle wiring by always using diode clamped relays when installing upfitter circuits.

CAUTION

All electronic products are susceptible to damage from Electrostatic Discharge or ESD. Ground yourself before handling or working with the module and harnessing by first touching chassis ground, such as the barrel of the cigarette lighter.



ILISC301 Module

Remove the lower dash panel below the steering column and find a suitable location to mount the ILISC301 module. Locate the module in an area away from external heat sources (engine heat, heater ducts, etc.). Do not mount the module until all wire harnesses are routed and secure. The last step of the installation is to mount the module.

Data Link Harness (4-Pin connector)

Locate the vehicle's OBDII Data Link Connector, mounted in the lower dash panel which was removed in the previous step.

1. Remove the OBDII connector from the panel by pushing in the tabs on the right and left sides of the connector and pulling it out from the back.
2. Plug the red connector from the ILISC301-A Data Link Harness into the vehicle's OEM OBDII connector just removed. Ensure the connection is fully seated and secure with the supplied wire tie.
3. Mount the White pass through connector from the ILISC301-A Data Link Harness in the former location of the vehicle's OBDII connector in the lower dash panel. It will snap into place when properly seated.
4. Secure the ILISC301-A Data Link harness so that it does not hang below the lower dash panel when the panel is re-installed.
5. Plug the free end of the Data Link harness into the mating 4-pin connector on the ILISC301-A module.

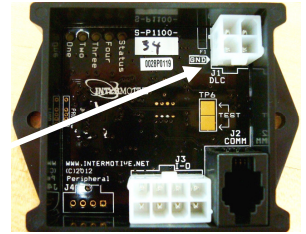

LED Dash Mounted Panel



Standard LED display panel



Optional Door Ajar LED panel

Locate a suitable position on the dashboard, within view of the driver to mount the LED Display Panel. Ensure that there is open space behind the dash for the harness where the panel is mounted. The harness is 40" in length, which is the maximum distance the display can be from the module.

1. Drill a 5/8" hole in the dash where the center of the display will be located.
2. Attach the Black 4-pin connector of the LED display panel harness to the module.
3. Run the other end of the harness under the dash and out through the 5/8" hole.
4. Attach the end to the LED Display Panel.
5. Place the panel on the dash, ensure it is level, and secure using supplied screws.



LED Panel Harness

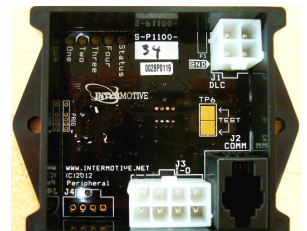

4 pin LED panel Connector

Control Inputs/Outputs - 8-pin connector

Reference ILISC301-A CAD drawings

The 8 pin Input/Output harness provides three different functions:

- Connection to the OEM shift lock solenoid
- Connection to the OEM Park Brake circuit—Optional
- Connection to the Wheel Chair Lift

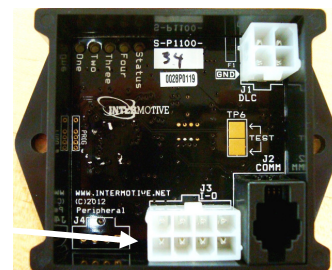

Shift Lock Solenoid Harness Installation

Remove the steering column plastic cover. Locate the black wiring harness below the ignition switch that terminates at the white 8-pin connector mounted to the steering assembly. Carefully remove the tape surrounding the wires. See photo.

1. Find the Blue wire and cut it in a location which will allow easy connection to both ends.
2. Slide the supplied heat shrink over both ends of the Blue wire.
3. Attach the side of the Blue wire coming from the shift lock solenoid to the ILISC301-A Blue wire, which is pin #2 of the 8 pin connector (see CADs for pin number identification). Use solder to make a solid, reliable connection.
4. Attach the other side of the OEM Blue wire coming from the PCM to the ILISC301-A harness Yellow wire, which is pin #6 on the 8 pin connector. Solder connection.
5. Position the two pieces of heat shrink directly over the solder joints and using a heat gun or other heat source, shrink to complete the shift lock wiring.

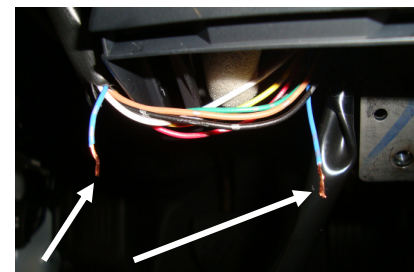
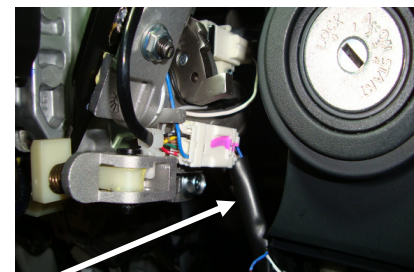

Optional Park Brake Harness Installation

Brown wire pin 4 – Connect this wire only if "key off" lift operation is desired. This optional Plug and Play T-harness (shown) connects to the OEM Park Brake switch located behind the Park Brake pedal, (as shown) such that the switch is made (GND) when the Park Brake is set. This connection is required if lift operation is desired when the vehicle ignition is OFF.

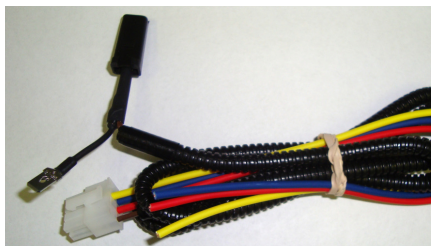

Park Brake connection behind pedal

Control Inputs/Outputs - 8-pin connector (continued)

Connection to the Wheelchair Lift

There are three different lift harness options available for the ILISC310-A. Refer to the appropriate section for the specific harness. The only signal required to interface to the lift is the Red wire Vehicle Secure signal. Lift door information is acquired over the vehicle's CAN network, so no upfitter door switch is required.

Generic Flying Lead Harness—A single Red wire flying lead Vehicle Secure signal is provided from pin 3 which should be wired to the lift to enable operation. Extend this wire (solder/heat shrink) back to the lift and connect per the lift instructions. If the lift draws more the 1/2A, a relay **with diode** must be added, as shown on the CAD drawing.

Braun Plug and Play Harness—connects the ILISC310-A Red wire to the Braun pin #6 of their 9-pin connector.

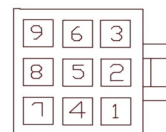

Braun

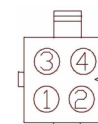

Ricon

Ricon Plug and Play Harness—connects the ILISC310-A Red wire to pin 86 of an integral relay in the harness which is connected to the Ricon 4 pin connector. See Ricon CAD page which shows Yellow, Red, and Black wires connected to the Ricon 4 pin connector pins 1, 2 & 3, respectively.

Note: A control relay may be needed to power some lifts, due to the lift drawing current of more than 1/2 amp on the Vehicle Secure signal. Install a diode or diode-clamped relay as shown on the CAD drawing. The diode is **required** to prevent high voltage spikes from damaging electronic control module components.

Connect the 8 pin connector to the module

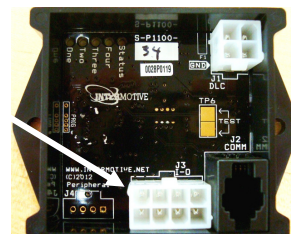

**** Optional Braun Plug & Play Relay Kit #900-00006 ****

Current models of Braun lifts draw more than 1 amp and will require the Braun plug and play relay kit.

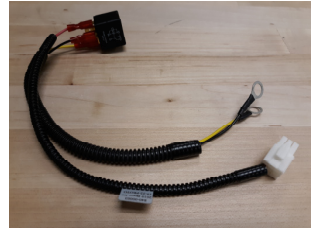

Red (from ILISC301 module) – This output provides 12V when it is safe to operate the lift. Cut the wire to the correct length and attach one of the pins provided using a crimping tool and insert at pin #86 of the included relay.

Red - Connect to pin #6 of the 9-pin Braun lift connector.

Yellow (eyelet) - Connect to External +12V at the lift.

Black (eyelet) - Connect to External ground at the lift.

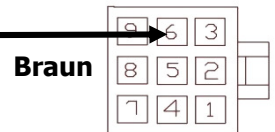

Optional Shift Lock Input: Connect the Yellow wire to any source which provides a High True output to enable shift lock and insert pin into pin #1 at the 8-pin connector.

- Pin #1 — N/C
- Pin #2 — BLUE (Shift Interlock Output)
- Pin #3 — RED (Vehicle Secure (12V) Output)
- Pin #4 — BROWN (Optional Park Brake (GND) Input)
- Pin #5 — N/C
- Pin #6 — YELLOW (Shift Interlock Output)
- Pin #7 — N/C
- Pin #8 — N/C

Connect the 8 pin connector to the module

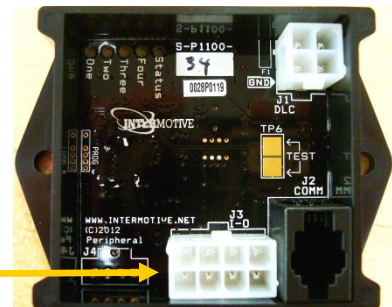

Reconnect vehicle battery

ILISC301 Module

Ensure all harnesses are properly connected and routed and are not hanging below the dash area. Mount the module as described on Page one and secure using screws or double sided tape.

Place the included label where it can be easily seen (e.g., on the dash).

Reconnect Vehicle Battery

ILISC301-A Post Installation / Check List

The following checks **MUST** be made after installation of the system, to ensure correct and safe operation of the lift. If any of the checks do not pass, do not deliver the vehicle. Recheck all connections per the installation instructions. If needed, call InterMotive Tech Support for assistance.

Begin the checklist with the vehicle in the following state:

- Lift stowed
 - Lift Door closed
 - Rear door closed (If the side door is configured as your lift door).
 - Park Brake set (PB)
 - Transmission in Park (P)
 - Ignition off (Key off). Wait until the module goes into "Sleep" mode (all panel LED's OFF) which takes approximately 5 minutes after reconnecting the battery.
1. Verify the module wakes up when turning key on or opening door. All 5 LED's will illuminate for approximately 2 seconds. The lower icon LED's on the standard LED panel are backlit and will remain illuminated whenever the module is awake. See Operator Instructions page for definition of LED panel icons.
 2. Verify that the Park, the Park Brake, and Shift Lock LEDs remain illuminated.
 3. Attempt to deploy the lift. Verify the lift does **not** deploy with the Lift Door closed.
 4. Block wheels or otherwise make sure vehicle cannot roll. With key on, transmission in Neutral, Park Brake set, lift door open, verify the lift does **not** deploy with transmission in neutral.
 5. With key on, Lift Door open, Park Brake set and transmission in Park, all 5 LED's will be illuminated. Attempt to deploy the lift. Verify the lift deploys then stow the lift.
 6. With key on, Lift Door open, transmission in Park, release Park Brake. Verify Park Brake (PB) and Vehicle Secure LED's go out. Attempt to deploy the lift. Verify the lift does **not** deploy.
 7. With key on, Lift Door closed, Park Brake set, attempt to shift transmission out of Park. Verify transmission does **not** shift out of Park.
 8. With key on, Lift Door open, Park Brake released, attempt to shift transmission out of Park. Verify transmission does **not** shift out of Park.
 9. With key on, Lift Door closed, Park Brake released and Service Brake applied, attempt to shift transmission out of Park. Verify transmission shifts out of Park.

If any of the previous Post Installation tests fail, enter diagnostic mode below.

Lift Interlock Diagnostic Mode Testing

Enabling Diagnostic Mode allows a visual indication of system status and is a good troubleshooting tool when used in conjunction with the above tests. The module is fully functional in this mode. Enter Diagnostic Mode by the following steps.

1. Place transmission in Park and turn ignition switch to run position.
2. Short the two Gold Test Pads together on the module to go into Diagnostic Mode. LED's on the module will prove out, then become status indicators:

- LED 1 will be on when Shift Lock enabled.
- LED 2 will be on when transmission is in park.
- LED 3 will be on when Park Brake is set.
- LED 4 will be on when Lift Door is open.
- LED marked "status" indicates "Vehicle Secure" or "Lift enabled" meaning there is 12V on Pin 3 (Red wire) which connects to the lift.

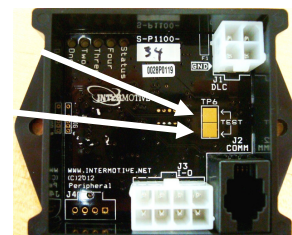

Cycling the key, or shorting the test pads again will exit Diagnostic Mode and all module LED's will be off.

ILISC301-A Post Installation / Check List (continued)

Selecting which door is the Lift Door

The module comes from the factory with the rear door defined as the Lift Door, but can be changed to the passenger side slider door of the vehicle. To do this, perform the following steps:

1. Sit at the wheel with all doors closed, vehicle in Park, and Park Brake ON.
2. Have the vehicle Key in the ON position.
3. Put the ILISC301-A module into Diagnostic mode (see previous section.)
4. Press and release the Service Brake rapidly several times until all LED's on the module turn ON. NOTE: all LED's on the panel display will blink as well.
5. There is a 1 minute window to select which door (passenger slider or rear) will be the Lift Door. To do this, open the required door. The module will detect this, store the information, and from this point, the selected door becomes the Lift Door. If the 1 minute time elapses before a door is selected, the Lift Door remains as it was. Verify the correct Lift Door by opening and closing it while observing the display panel for proper indication.

Once the door has been reconfigured or the 1 minute window has elapsed, the module and display panel will return to normal operation.

Leave with vehicle

Operating Instructions ILISC301-A Wheelchair Lift Shift Interlock

2012—2019 Nissan NV Van

The ILISC301-A is an electronic system for controlling wheelchair lift operation. It will lock the shifter when the lift door is open which minimizes the possibility of driving away with the lift out. It also locks the shifter when Park Brake is set, which can prevent excessive brake wear. The ILISC301-A will not allow the lift to be used unless the transmission is in Park, Park Brake is set, and the Lift Door is open.

Key On operation:

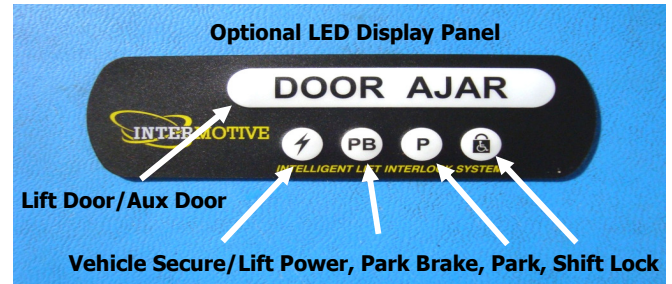

- When the vehicle is in "Park" the (P) LED will be illuminated.
- When the Park Brake is applied, the (PB) LED will be illuminated.
- When the Lift Door is open, the Lift Door LED will be illuminated. (Door Ajar LED on optional display panel).
- When in Park and either the Park Brake is applied or the Lift Door is open, the Shift Lock LED will be illuminated, and the transmission will not shift out of Park.
- With the vehicle in Park, Park Brake applied and Lift Door open, the Vehicle Secure LED will be illuminated and the lift will be operational. At this point **all** LED's will be illuminated on either display panel.

Key off operation (if optional Park Brake input is supplied):

The module goes into sleep mode approximately 5 minutes after the key is turned off, and will wake up when either the key is turned on, or any door is opened. Upon wake up, all display LED's will illuminate for approximately 2 seconds as a "prove out". The backlit LED's remain on as long as the module is awake. Functioning with key off is similar to key on operation. The vehicle must be in Park, with Park Brake set, and the Lift Door open (all LEDs on) to operate the lift.

When the side door is configured as the lift door, the rear door must remain closed during lift operation.

Optional Display Panel: If equipped with the optional LED display panel, the Door Ajar LED will blink if any door other than the lift door is open. If the Lift Door is open, the Door Ajar LED will be on solid, taking priority over any other door. If using the standard display panel, there will be no indication for any doors other than the Lift Door.

Do not leave the lift door open when the vehicle is not in use. This will cause a draw on the vehicle's electrical system as the lift will remain powered up, which could result in a dead battery.

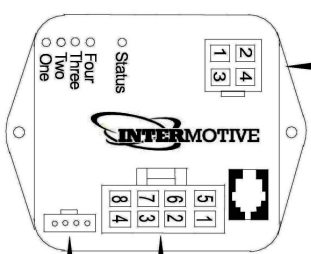
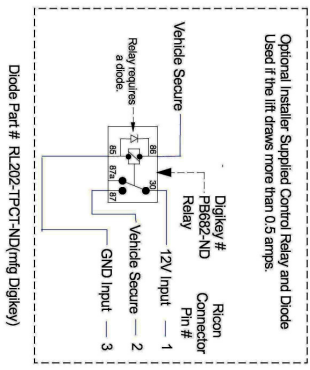
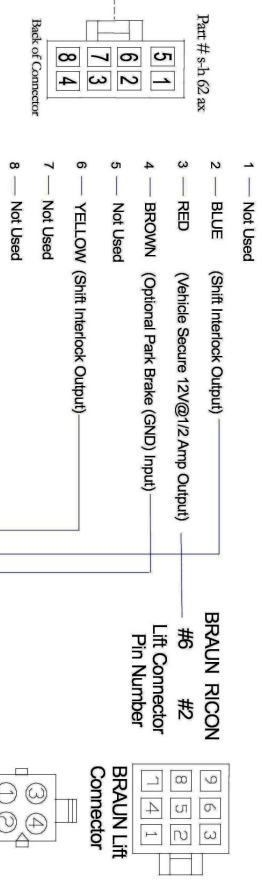
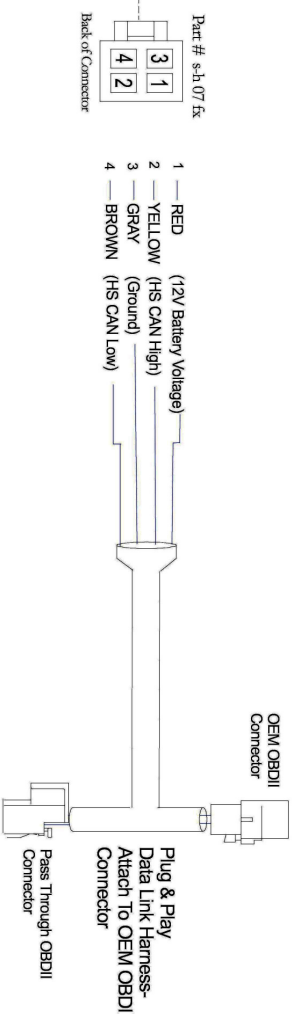

ILISC301-A
 Part # s-m 1100-22

Submit product registration at www.intermotive.net

If the ILISC301-A fails any step in the Post Installation Test, review the installation instructions and check all connections. If necessary, call InterMotive Technical Support at (530) 823-1048.

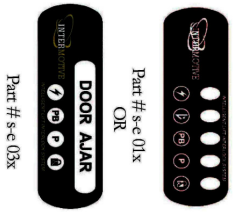

**** Optional Ricon Plug & Play Lift Harness ****

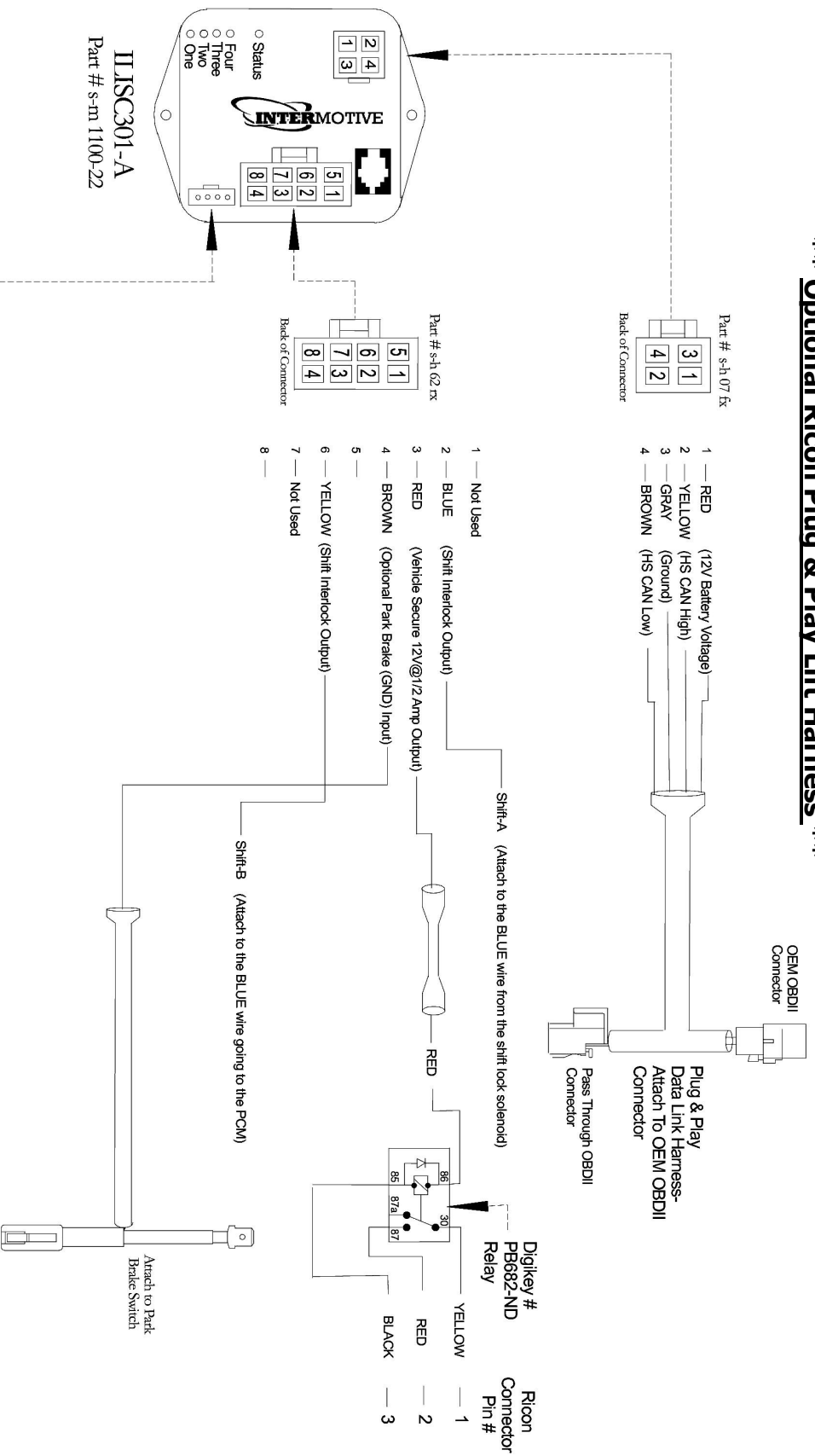

ILISC301-A
Part # s-m 1100-22

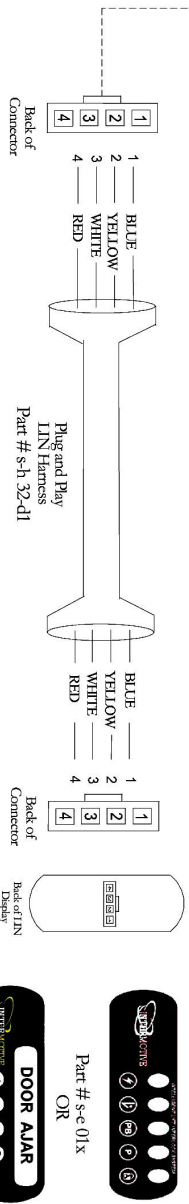

Submit product registration at www.intermotive.net

If the ILISC301-A fails any step in the Post Installation Test, review the installation instructions and check all connections. If necessary, call InterMotive Technical Support at (530) 823-1048.

**** Optional Braun Plug & Play Lift Harness ****

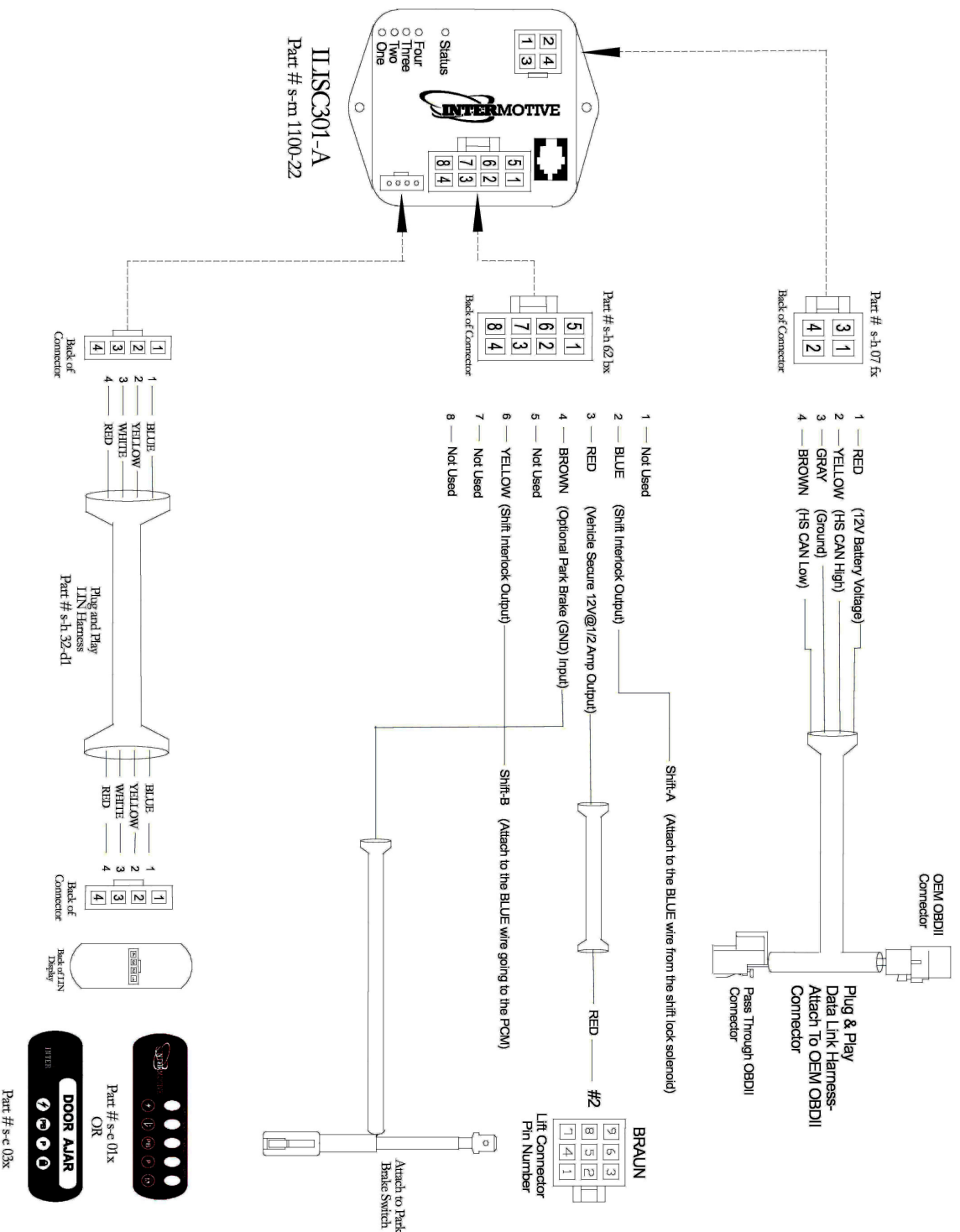

Submit product registration at www.intermotive.net

If the ILISC301-A fails any step in the Post Installation Test, review the installation instructions and check all connections.
If necessary, call InterMotive Technical Support at (530) 823-1048.

** Braun Plug and Play with 2019 Relay Kit **

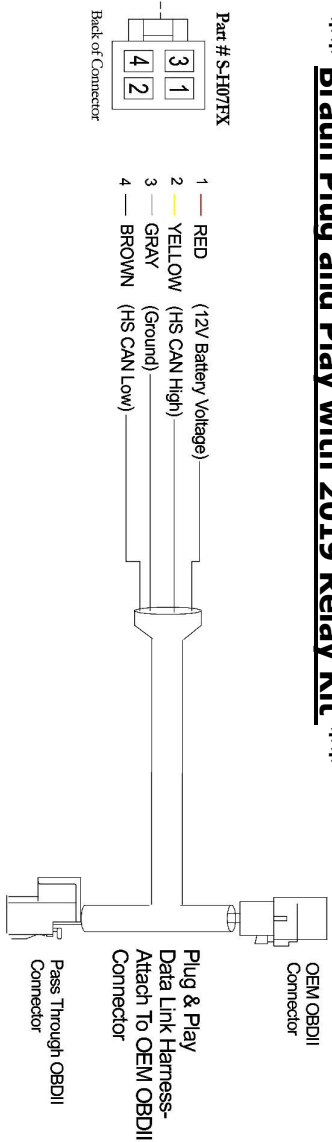

Part # S-H07FX

- 1 — RED (12V Battery Voltage)
- 2 — YELLOW (HS CAN High)
- 3 — GRAY (Ground)
- 4 — BROWN (HS CAN Low)

Back of Connector

OEM OBDII Connector

Plug & Play Data Link Harness- Attach To OEM OBDII Connector

Pass Through OBDII Connector

8w Part # 840-00006

- Part Kit Part # 900-00002
- 1 — Not Used
 - 2 — BLUE (Shift Interlock Output)
 - 3 — RED (Vehicle Secure 12V@1/2 Amp Output)
 - 4 — BROWN (Optional Park Brake (GND) Input)
 - 5 — Not Used
 - 6 — YELLOW (Shift Interlock Output)
 - 7 — Not Used
 - 8 — Not Used

Back of Connector

Part # 840-00003

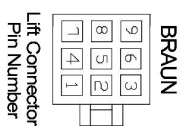

* Connect to External +12V and Ground

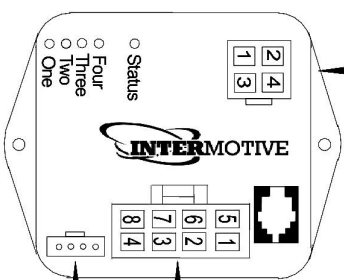

ILISC301-A
Part # S-M1100-22

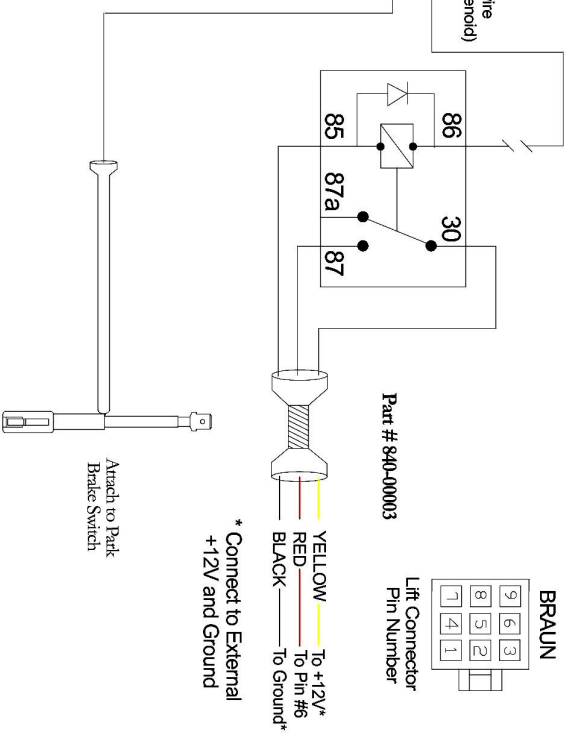

Attach to Park Brake Switch



Plug and Play LIN Harness
Part # S-H32-DX

Back of Connector

Back of LIN Display

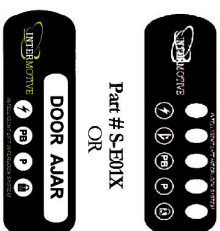

Part # S-E03X

Submit product registration at www.intermotive.net

If the ILISC301-A fails any step in the Post Installation Test, review the installation instructions and check all connections. If necessary, call Intermotive Technical Support at (530) 823-1048.