

SMM511 Surveillance Mode Module™

2016-2019 Ford Police Interceptors (Utility Only)



Introduction

The SMM511 for Ford Police Interceptors (Sedan & Utility) uses the vehicle's OEM sensors to inform an officer if anyone is behind the vehicle. The OEM sensors can include Blind Spot Information System (BLIS) and/or Rear Backup sensors with the backup camera if equipped. If no OEM Rear Backup sensors are installed on the vehicle, the HAWK511 can be installed (see HAWK511 instructions for more information). Anytime Surveillance Mode is active, the rear camera will also be turned on. If any of the sensors detect a presence while in Surveillance mode, the system will activate a chime indicating a sensor has been tripped, all the door's will lock, the driver's window will roll up, and the reverse 'back-up' lights will flash.

Installation Instructions

Disconnect vehicle battery before proceeding with installation



WARNING
Disconnect the battery to
prevent setting a check engine
light.

IMPORTANT - READ BEFORE INSTALLATION

It is the installer's responsibility to route and secure all wiring harnesses where they cannot be damaged by sharp objects, mechanical moving parts and high heat sources. Failure to do so could result in damage to the system or vehicle and create possible safety concerns for the operator and passengers.

It is important to avoid placing the module where it could encounter strong magnetic fields from high current cabling connected to motors, solenoids, etc. Also avoid radio frequency energy from antenna's or inverters next to the module. Finally, avoid high voltage spikes in vehicle wiring by always using diode clamped relays when installing upfitter circuits.

SMM511 Module

Remove the lower dash panel below the steering column area and find a suitable location to mount the SMM module. Locate the module in an area away from any external heat sources (engine heat, heater ducts, etc.). Do not mount the module until all wire harnesses are routed and secure. The last step is to mount the module.

Installation for Automatic Window Function

To install Surveillance Mode, it will be necessary to tap into the driver's side window switch. Remove the driver's door trim panel following the appropriate instructions.

Utility Interceptor

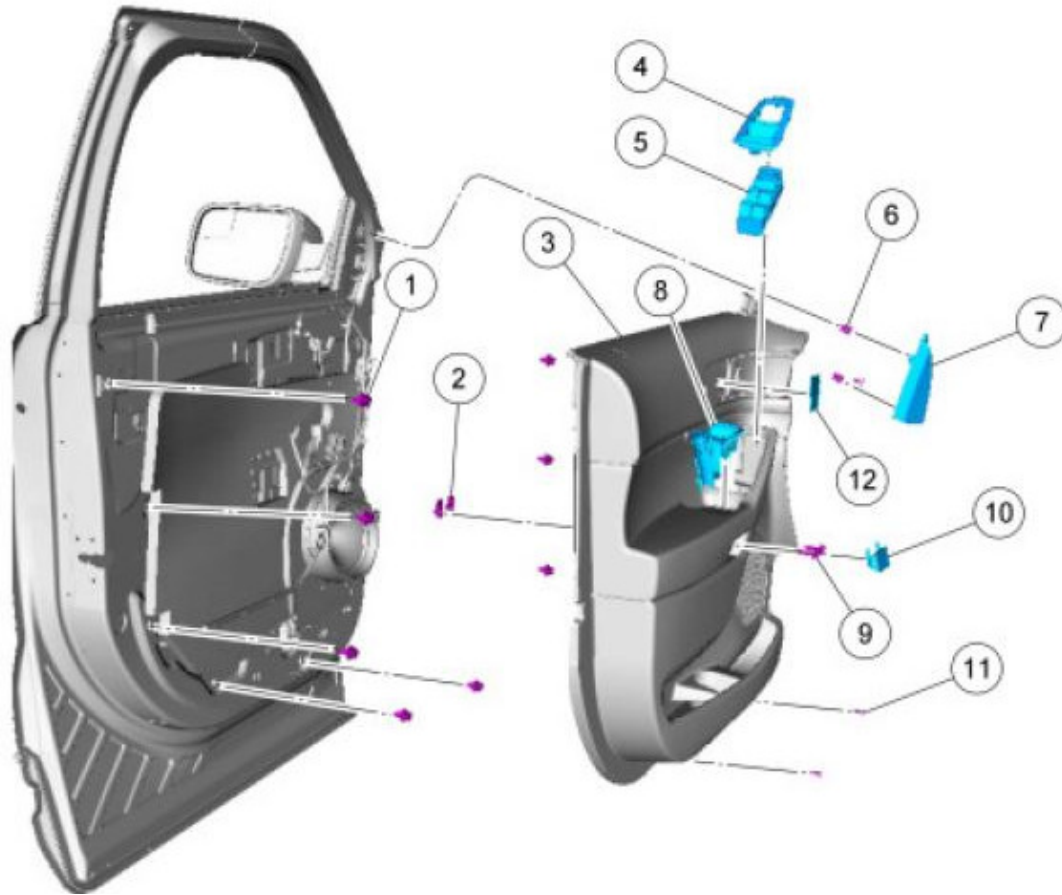

N0131446

Item	Service Part Number	Description	Torque	Material Name	Notes
1	W713297	Front door trim panel retaining clip (8 required)	-	-	-
2	W520832	Front door trim panel nut (2 required)	-	-	-
3	23942 / 23943	Front door trim panel (Right Hand (RH) / LH)	-	-	-
4	14524 / 14525	Front door window switch bezel (Right Hand (RH) / LH)	-	-	-
5	14529	Front door window switch (Right Hand (RH) / LH)	-	-	-
6	W710338	Sail panel clip (3 required)	-	-	-
7	17K709	Sail panel (Right Hand (RH) / LH)	-	-	-
8	22634 / 22635	Front door trim panel handle cup (Right Hand (RH) / LH)	-	-	-
9	W505424	Front door trim panel bolt (2 required)	7 Nm (62 lb-in)	-	-
10	24056 / 24057	Front door trim panel bolt cover (Right Hand (RH) / LH)	-	-	-
11	W708392	Front door trim panel screw (2 required)	1 Nm (9 lb-in)	-	-
12	22620	Front interior door handle bolt cover	-	-	-

Removal

1. Using a non-marring tool, release the 3 sail panel clips and remove the sail panel.

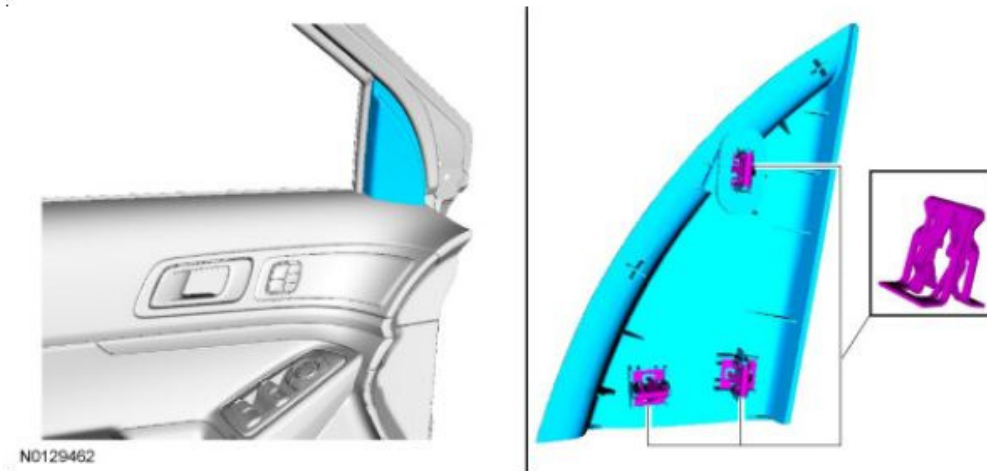

2. Remove the front window control switch. [REFER to Section 501-11, Window Control Switch.](#)
3. Using a non-marring tool, remove the front interior door handle bolt cover.

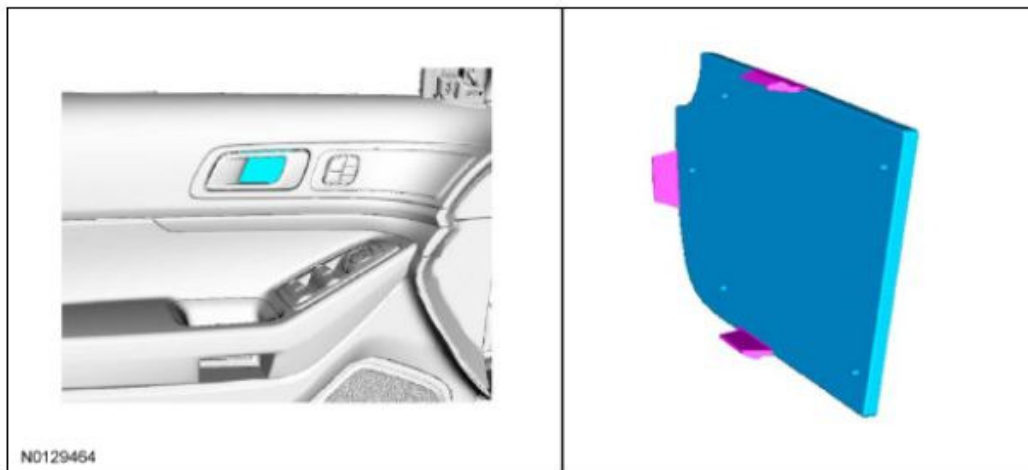

4. Using a non-marring tool, remove the front door trim panel bolt cover.

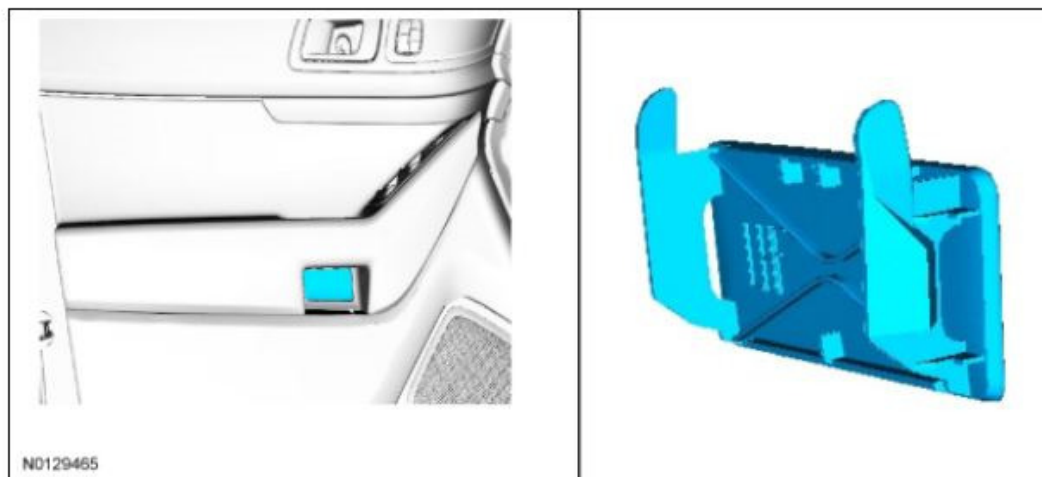

5. Remove the interior door handle bolt and the 2 front door trim panel bolts.

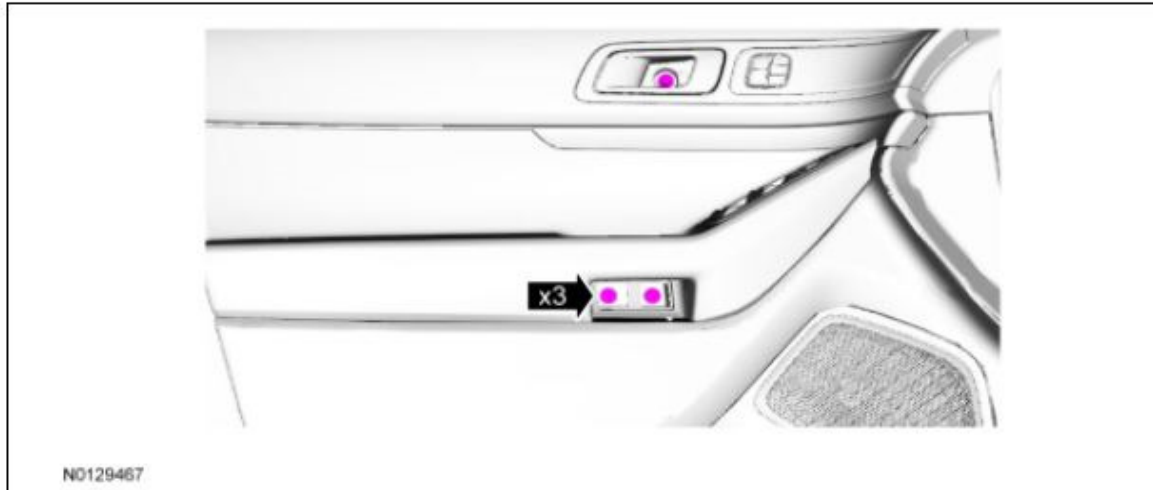

6. Remove the 2 front door trim panel screws.



7. Using a non-marring tool, release the 8 front door trim panel clips.

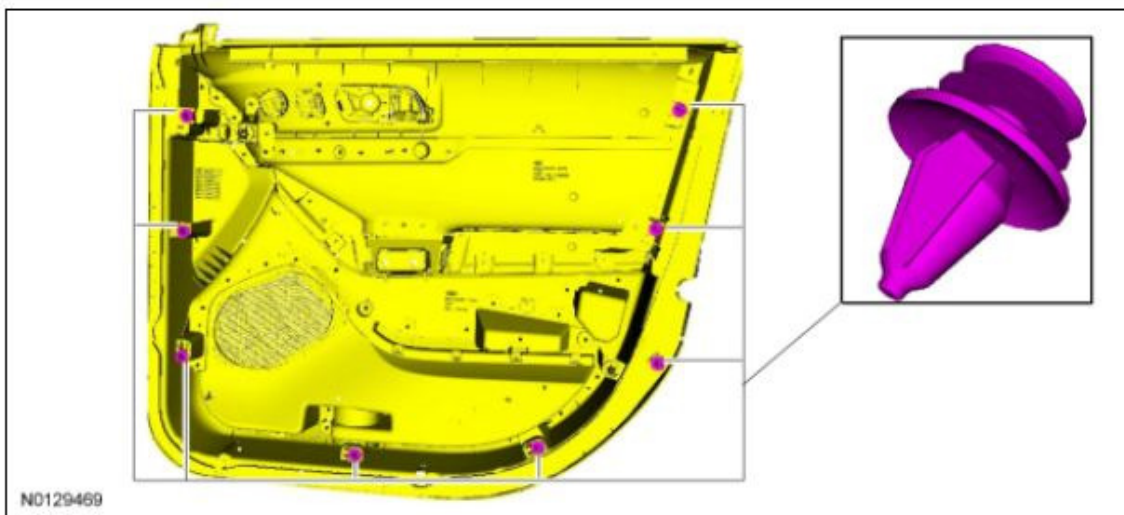

8. **NOTE:** *High-end options shown, all others similar.*

Disconnect the door trim panel electrical connector.

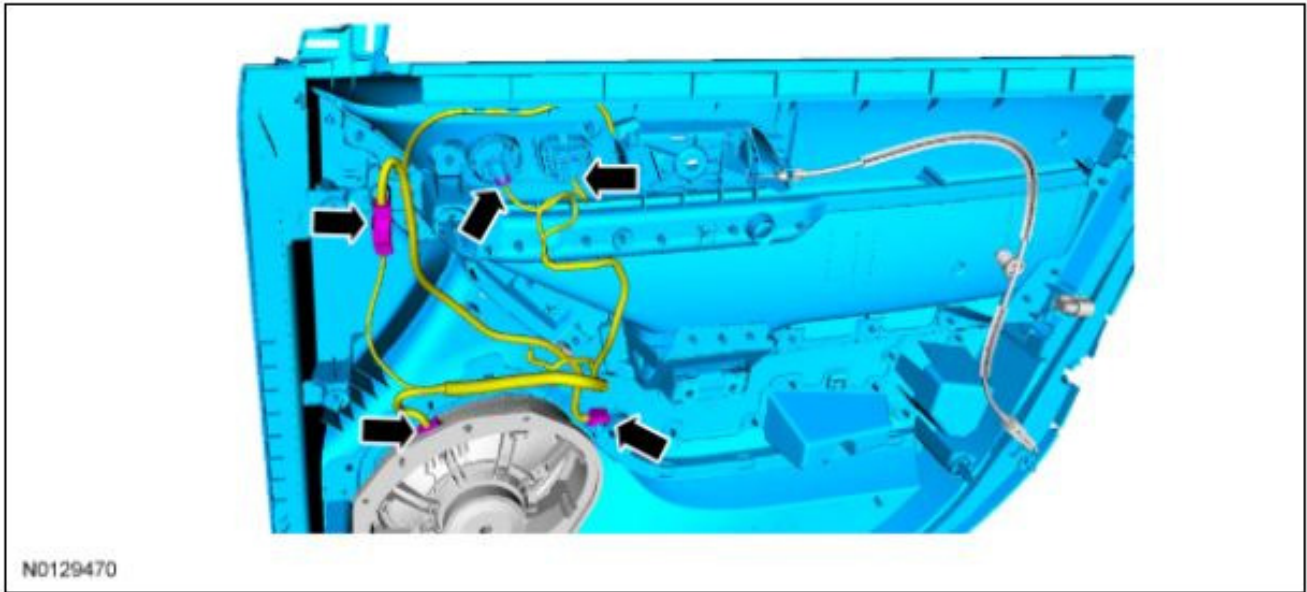

9. Release the front interior door handle cable and remove the front door trim panel.

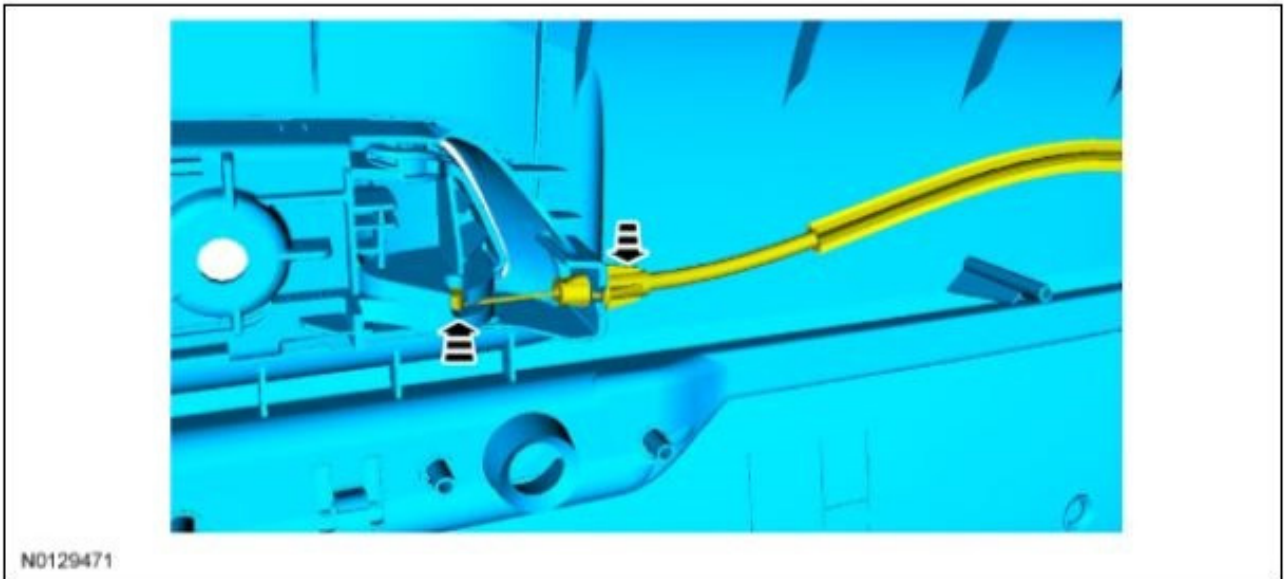

After removing the door trim panel, continue to the "routing wire into door panel" section.

Routing Wire into Door Panel (Utility)

It's recommended to drill a hole in the driver's side kick panel (see photo). The hole must be large enough to accommodate a single loomed wire and a grommet.

Route the Grey wire from pin 2 of the 12 pin connector through the hole.



Remove the boot between the vehicle and the door and route the Grey wire through the boot and into the door panel. Removing the speaker from the door panel may be necessary.



Install a grommet in the hole previously drilled in the kick panel.

After routing the Grey wire into the door panel, continue to the "Tapping into the Window Switch" section.



Tapping into the Window Switch

The procedure differs between the type of switch used for the drivers window.

One Touch Up ONLY

Locate the master Window Adjust Switch (20 pin connector) and connect the Grey wire from Pin 2 on the 12 pin connector at the SMM module to the Blue/Grey wire Pin 17 using solder and tape.



Connector:	Description	Color	Harness	Base Part #	Service Pigtail
C504	MASTER WINDOW ADJUST SWITCH	BK	14631	14529A	Not Available

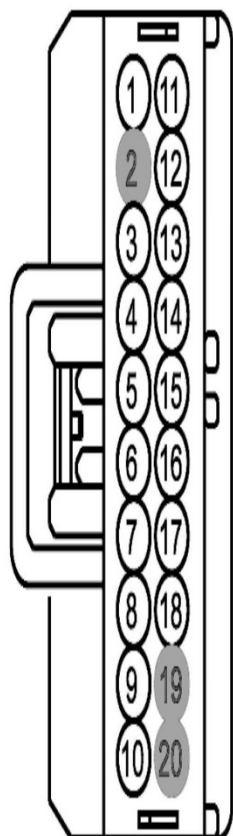

Pin	Circuit	Gauge	Circuit Function	Qualifier
1	GD233 (BK)	22	GROUND - COWL SIDE/PILLAR A LEFT (BC3T)	
2	*	*	Not Used	
3	CPW14 (VT-WH)	22	SWITCH - POWER WINDOW DRIVER # PASSENGER LOCK OUT (ENABLE)	
4	CPM23 (GY)	22	SWITCH - POWER MIRROR # COMMON ALL MOTORS (LEFT AND RIGHT)	
5	CPM16 (BN-BU)	22	SWITCH - POWER MIRROR # LEFT MIRROR RIGHTWARD (IF PLUS)	
6	CPM17 (BU-GN)	22	SWITCH - POWER MIRROR # LEFT MIRROR UPWARD (IF PLUS)	
7	CPM20 (BN-WH)	22	SWITCH - POWER MIRROR # RIGHT MIRROR RIGHTWARD (IF PLUS)	
8	CPM21 (YE-VT)	22	SWITCH - POWER MIRROR # RIGHT MIRROR UPWARD (IF PLUS)	
9	CPW74 (YE-GN)	22	SWITCH - POWER WINDOW DRIVER # FRONT PASSENGER LOCK OUT BYPASS	
10	CBP32 (GN-VT)	22	FUSE - 32 OR CIRCUIT BREAKER	
11	CPW12 (GN-OG)	22	SWITCH - POWER WINDOW DRIVER # FRONT PASSENGER DOWN	
12	CPW13 (BN-YE)	22	SWITCH - POWER WINDOW DRIVER # FRONT PASSENGER UP	
13	CPW17 (BN-GN)	22	SWITCH - POWER WINDOW DRIVER # REAR RIGHT DOWN	
14	CPW18 (GY-VT)	22	SWITCH - POWER WINDOW DRIVER # REAR RIGHT UP	
15	CPW16 (BU-OG)	22	SWITCH - POWER WINDOW DRIVER # REAR LEFT UP	
16	CPW15 (YE)	22	SWITCH - POWER WINDOW DRIVER # REAR LEFT DOWN	
17	CPW11 (BU-GY)	22	SWITCH - POWER WINDOW DRIVER # DRIVER UP	
18	CPW10 (YE-VT)	22	SWITCH - POWER WINDOW DRIVER # DRIVER DOWN	
19	*	*	Not Used	
20	*	*	Not Used	

NON-One Touch Up

1. Locate 4 pin Connector on window switch (C535B).
2. Cut the Blue/Grey wire (pin 4 on C535B) and attach the motor side of this wire to Pin 30 of the relay.
3. Attach the window switch side of the Blue/Grey wire to pin 87A of relay.
4. Using solder and tape, parallel tap into the Blue wire (pin 3 on C535B) and attach to pin 87 of the relay.
5. Using solder and tape, parallel tap into the Black wire (pin 1 on C535B) and attach to pin 85 of the relay.
6. Locate the Grey wire, Pin 2 of the 12 pin connector on the SMM module and attach to pin 86 of the relay.

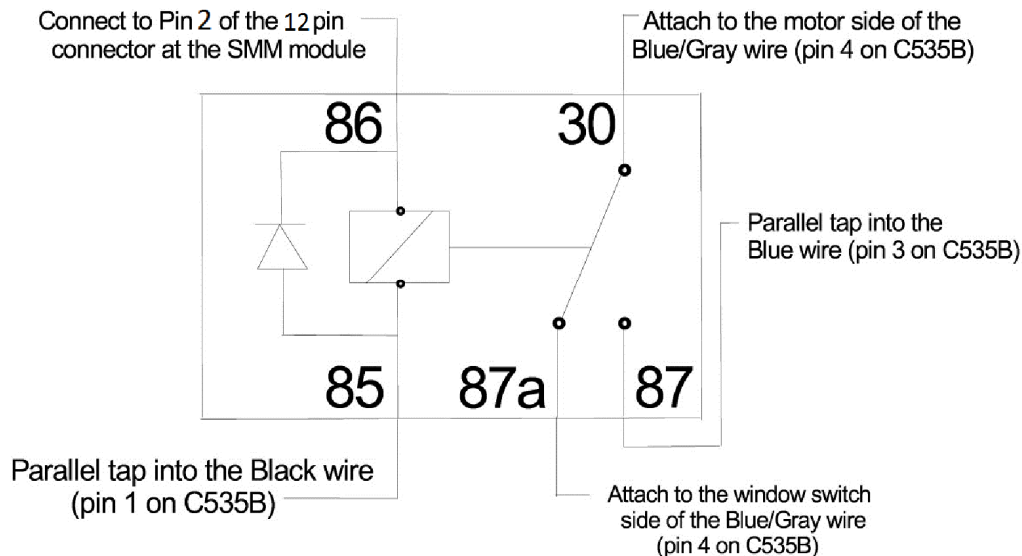

Connector:	Description	Color	Harness	Base Part #	Service Pigtail
C535B	MASTER WINDOW CONTROL SWITCH		14631	part# N/A	See Below

Pin	Circuit	Gauge	Circuit Function	Qualifier
1	GD233 (BK)	12	GROUND - COWL SIDE/PILLAR A LEFT	
2	CPW10 (YE-VT)	12	SWITCH - POWER WINDOW DRIVER # DRIVER DOWN	
3	CBP01 (BU)	12	FUSE - 48 OR CIRCUIT BREAKER	
4	CPW11 (BU-GY)	12	SWITCH - POWER WINDOW DRIVER # DRIVER UP	

Installation for Reverse Camera Display on Rear View Mirror only

Note: Skip if Reverse Camera Display is located in the center stack.

To install Surveillance Mode, it will be necessary to tap into the camera input in the rear view mirror. Find the harness that goes up the A-Pillar near the parking brake as shown below.

1. Locate the harness going up to connector C317 and find the Blue/White wire.
2. **Verify** with a DVM that there is 12V on the Blue/White wire when the vehicle is in Reverse and 0V when the vehicle is in any gear other than Reverse.
3. Cut the Blue/White wire in the OEM harness.
4. Attach the BCM side of the wire to the Blue/White wire of the SMM Harness.
5. Attach the harness side of the wire to the Blue wire of the SMM Harness.

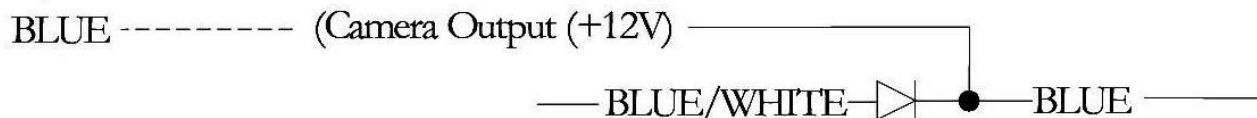
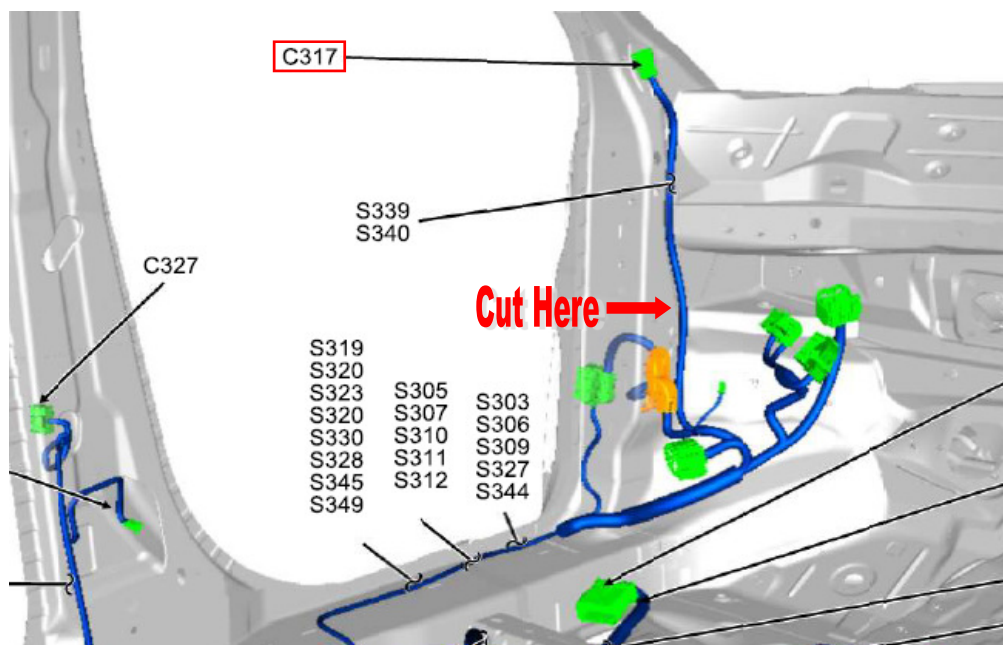

Optional Third Party Device Harness (S-H31NX)

This harness is to be used if a third party device will be installed with the SMM511. It will disable the third party device when the SMM is in Surveillance Mode. This will prevent the device from interfering with the SMM operation. See wiring diagram for installation instructions.

12 pin SMM connector pin-out definition

This connector contains the output pins. Each output is rated at 1/2A and is intended to drive relay coils or other low current loads.

The outputs are defined as follows:

- Pin #1 (Red wire) Only used if HAWK511 is installed
- Pin #2 (Grey wire) Window Output, +12V
- Pin #3 (Yellow wire) Activated Output, +12V
- Pin #4 (Orange Wire) Detected Output, +12V
- Pin #5 (White wire) Only used if HAWK511 is installed
- Pin #6 (Red wire jumped to pin 12)
- Pin #7 no-connect
- Pin #8 (Blue Wire) Camera Output, +12V
- Pin #9 Connect to Part # S-H31NX (Optional)
- Pin #10-11 are no-connects
- Pin #12 (Red wire jumped to pin 12)

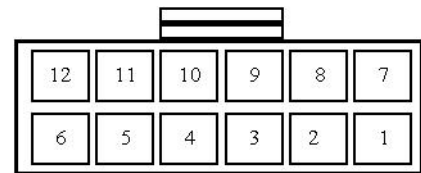

Outputs

Window Output - used to raise the window up when sensors are tripped in Surveillance Mode.

Activated Output - Active when surveillance mode is enabled.

Detected Output - Active when a sensor is set off while in surveillance mode.

Camera Output - used to enable the camera display in the rear view mirror.

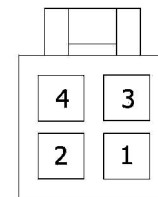

4 pin Input connector definition

This connector contains the input to enable Surveillance Mode. A momentary switch connected to ground is required for this input. (Not included in Kit)

- Pin #1 - Not Used
- Pin #2 - Not Used
- Pin #3 - (Green/White stripe) SMM input, Active low
- Pin #4 - Not Used

Surveillance Mode Post Installation Instructions

Preferably test with two people so one person can activate the rear sensors.

1. Place car in Park, close the driver door, and do not apply the Service Brake.
2. Put the driver and passenger door windows all the way down and unlock doors.
3. Apply Surveillance Mode input and verify rear camera display turns on.
4. Have one person trip the sensors by walking behind the vehicle.
5. Verify that the window goes up, all doors lock, and the reverse 'back-up' lights flash.
6. Verify rear camera display turns on.
7. Open driver door to exit surveillance mode and verify rear camera turns off and the reverse lights shut off.

If the SMM511 fails any step in the Post Installation Test, call InterMotive Technical Support at (530) 823-1048.

SMM511 Module Mounting

Ensure all harness are properly connected and routed, and are not hanging below the dash area. Mount the SMM511 module using screws or double sided tape. Reinstall the lower dash panel.

Gateway Plug and Play Harness (6-pin connector)

1. Locate the vehicles Gateway Module (C2431). It will be mounted below the lower left dash panel.
2. Remove the harness behind the Gateway module by pressing the locking tab and pulling outward.
3. Plug the Female side of the InterMotive Gateway Harness into the back of the Gateway module. Ensure the connection is fully seated and secured by the locking tab.
4. Plug the Male side of the InterMotive Data Link Harness into Gateway harness.
5. Secure the SMM Gateway harness so that it does not hang below the lower dash panel.

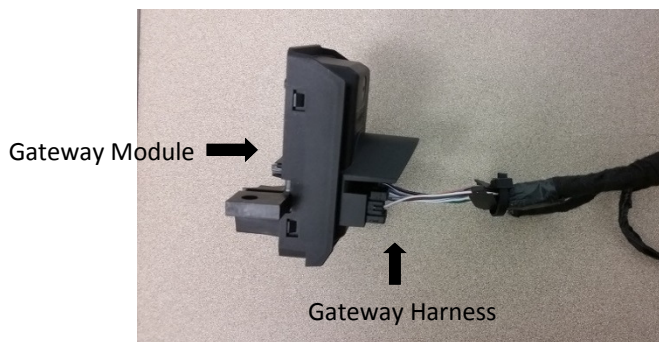

InterMotive Plug and Play Gateway Harness

Surveillance Mode

2016-2019 Ford Interceptor Utility

Introduction

Surveillance Mode uses the Rear Backup sensors and/or Blind Spot Information System (BLIS) and the Backup Camera. If any of the sensors detect a presence while in Surveillance Mode, the vehicle will chime indicating which sensor tripped, and then the SMM will lock the doors and roll the driver's window up when Ground is momentarily applied to Pin 3 on the 4 pin connector (J6). Surveillance Mode will still be active after a sensor is tripped to allow the backup camera to stay on.

To enter Surveillance Mode, ALL five preconditions must be met:

- Transmission must be in park.
- Vehicle speed must be zero.
- Driver door must be closed.
- Service brake must not be applied.
- Momentarily ground the Green/White wire Pin 3 on the 4 pin connector.

To exit Surveillance Mode, any condition may be applied:

- Pin 3 of the 4 pin connector Green/White wire momentarily grounded.
- Driver door is opened.
- Service brake is pressed.

Note: Exiting Surveillance Mode results in the AM/FM radio clicking off momentarily as well as causing the headlights to briefly flash.

If Flashing Reverse Lights are enabled, the Reverse Lights will flash at about 10 hertz when a presence is detected. This will turn off when either of these conditions are met:

- The transmission is cycled out of park.
- Disable Surveillance Mode by momentarily grounding input on Green/White wire.
- Cycling the key position.

Diagnostics

Diagnostic mode is entered by shorting the two "Test" pads together on the module. The module provides diagnostic LEDs which illuminate according to the following table. To exit this mode, cycle the key. For diagnostics for the SMM portion of the PIM module, momentarily short the two "Test" pads TWO times. The Status Light will Flash 5-5.

LED #	Diagnostic Mode LED Descriptions
1	SMM Input Ground Active
2	TR = Park
3	VSS < 0
4	Driver Door Closed
5	Service Brake Applied
6	Surveillance Mode Active
8	LED ON - BLIS Trigger Activated
9	LED ON - Flashing Reverse Lights Activated



Toggle BLIS Trigger

The BLIS Trigger is defaulted ON, the following procedure must be performed to toggle the BLIS Trigger off:

1. Turn Key to the RUN position.
2. Short the test pads on the module twice and verify the Status LED flashes a 5-5 code.
3. Open the Driver's Door.
4. Apply and hold the Service Brake.
5. Momentarily ground Pin 3 of the 4 pin connector **THREE** times within 5 seconds. All LED's will flash once and turn off for confirmation.
6. Cycle Key off and on for changes to take effect.
7. Repeating this procedure will toggle the BLIS Trigger ON/OFF.

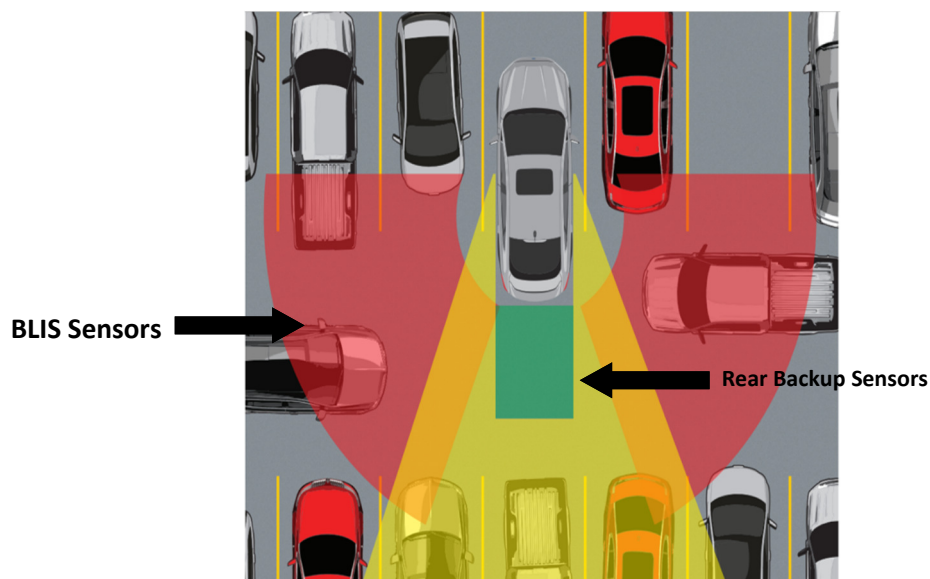

Toggle Flashing Reverse Lights

The Flashing Reverse Lights are defaulted ON, the following procedure must be performed to disable them:

1. Turn Key to the RUN position.
2. Short the test pads on the module twice and verify the Status LED flashes a 5-5 code.
3. Close the Driver's Door.
4. Apply and hold the Service Brake.
5. Momentarily ground Pin 3 of the 4pin connector THREE times within 5 seconds. All LED's will flash once and turn off for confirmation.
6. Cycle Key off and on for changes to take effect.
7. Repeating this procedure will toggle the Flashing Revers Lights ON/OFF.

U.S. Patent #9,469,261

Optional Harness for Third Party Devices

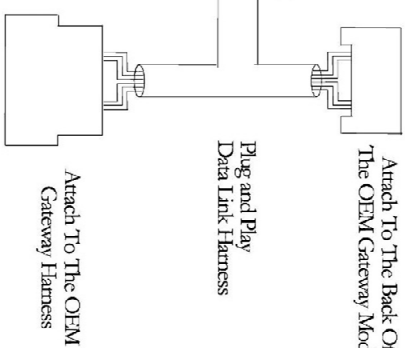
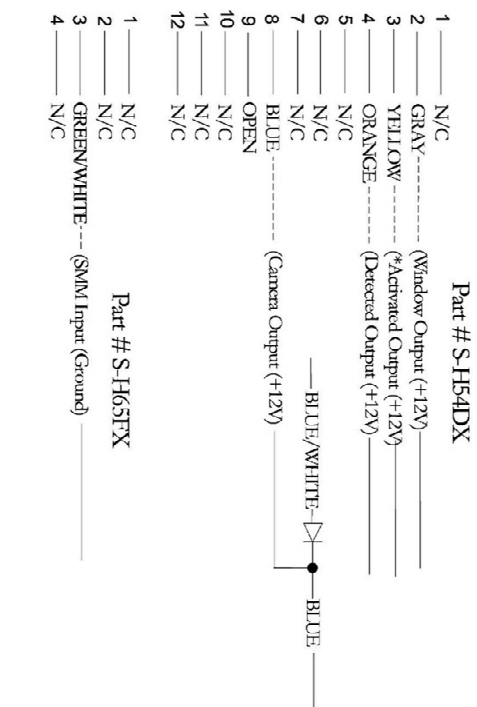
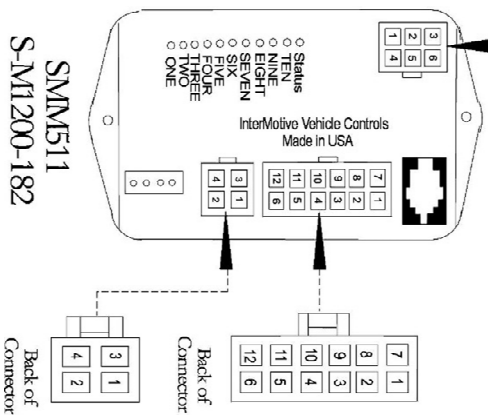
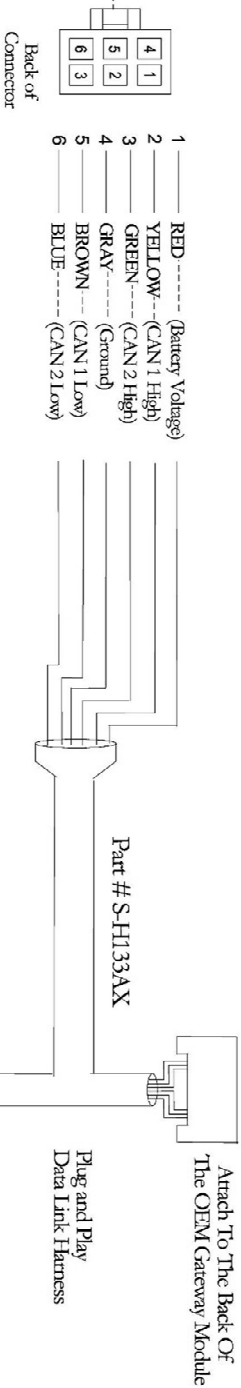
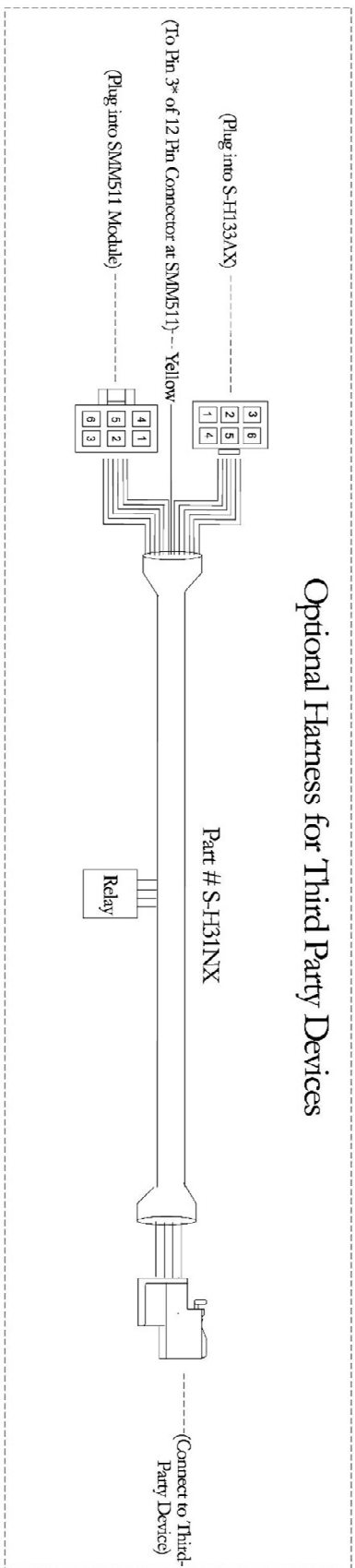

If the SMM fails any step in the System Operation Test, review the installation instructions and check all connections.

If necessary, call InterMotive Technical Support at (530) 823-1048

Submit product registration at www.intermotive.net

SM511 Installed With HAWK511

Optional Harness for Third Party Devices

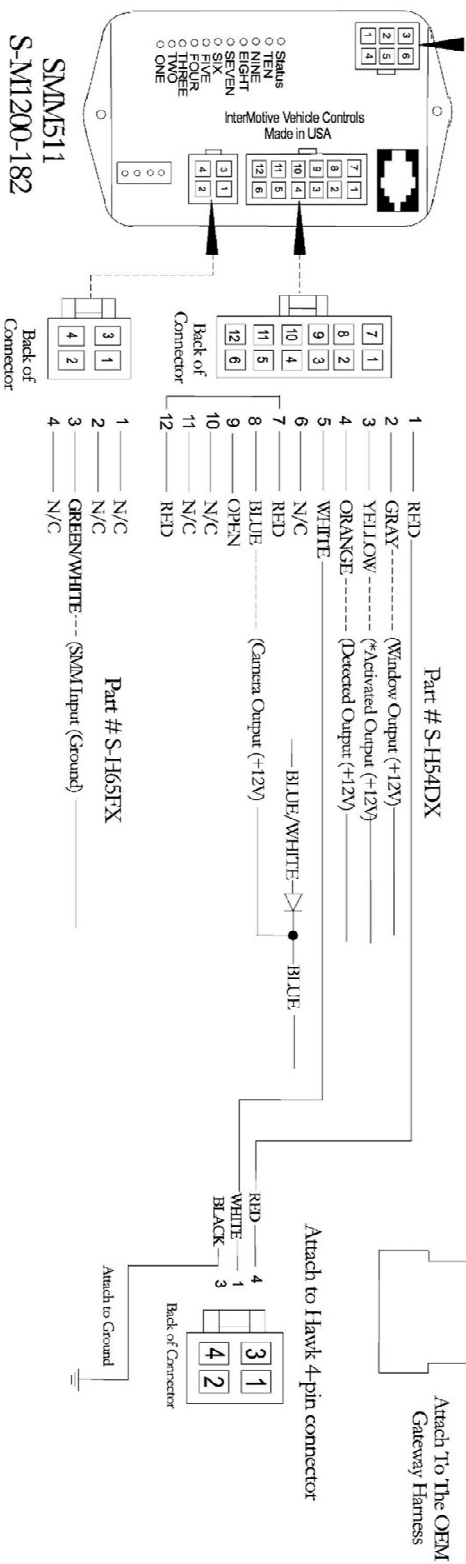
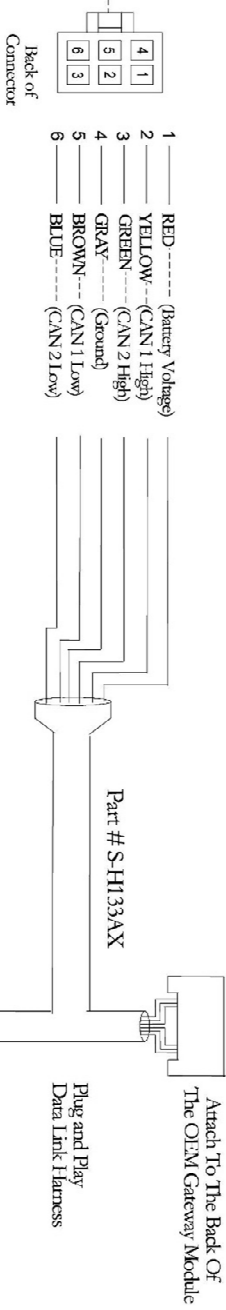
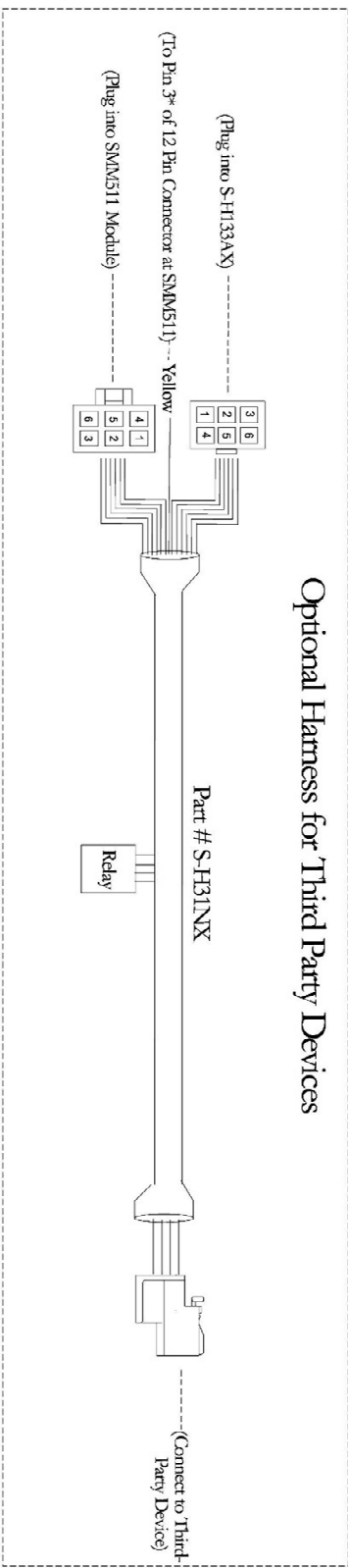

If the SM511 fails any step in the System Operation Test, review the installation instructions and check all connections.

If necessary, call InterMotive Technical Support at (530) 823-1048

Submit product registration at www.intermotive.net