

**ILISC: Intelligent Lift  
Interlock System**

**INTERMOTIVE**  
**VEHICLE  
CONTROLS**

An ISO 9001:2015 Registered Company

# Intelligent Lift Interlock System™

ILISC: Shift Interlock for Manual Doors

## Overview

- Prevents the vehicle from shifting out of Park if the wheelchair lift or ramp is in use or until properly stowed
- Prohibits lift operation unless the vehicle is in a secure state
- System is fully compliant with FMVSS 403/404 and the Americans with Disabilities Act (ADA) for wheelchair lift interlocks
- Simple plug and play connections to the OEM chassis

## Features

- Dash-mounted LED display panel provides system status
- Allows the lift to be operated from outside with the engine off
- Optional vehicle lockdown while passenger door is open
- Uses Intermittent Fault Filter™ (IFF) technology to eliminate erroneous lift door signals

*Product features may vary by make, model or year. See instructions for complete details.*

Proudly distributed by  
**LGS GROUP**  
AUTOMOTIVE TECHNOLOGIES

**(775) 831-2002**

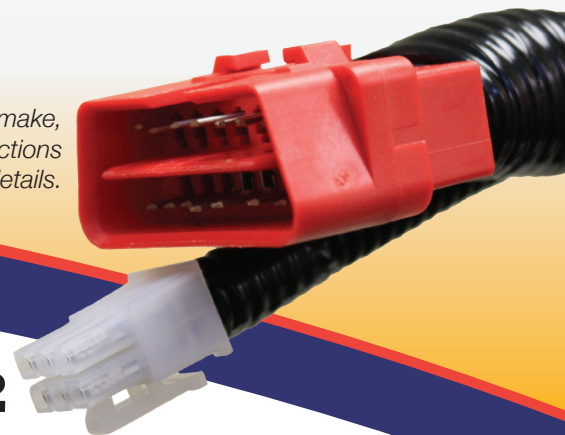

# Details

## EXAMPLE SCHEMATIC

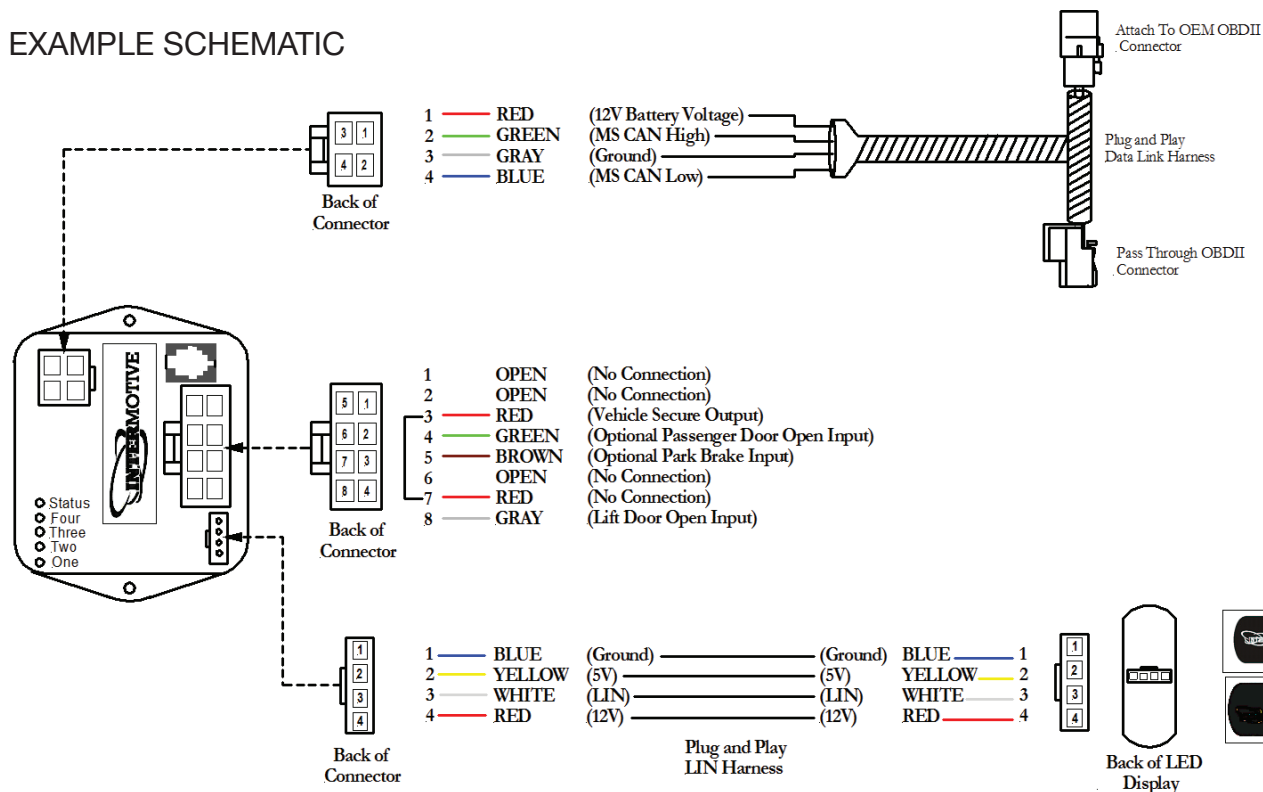

## SPECIFICATIONS

Number of Inputs	Three active low (lift door open, Park Brake and passenger door open)
Number of Outputs	Two high/low (vehicle secure and shift lock)
Current Draw	70 mA
Quiescent Draw	3 mA (sleep current)
CAN Speed	High and medium speed
Temperature Range	-40°C to 80°C
Dimensions	3" L x 2" W x 1" H