

**TempGuard**

**INTERMOTIVE**  
**VEHICLE**  
**CONTROLS**

*An ISO 9001:2015 Registered Company*

# TempGuard

## ECT Warning System

### Overview

- Monitors the engine coolant temperature (ECT) and initiates a warning if parameters are exceeded
- Reduces the chances of the engine overheating, which could lead to expensive repairs
- Simple plug and play connections for CAN data

### Features

- Configurable temperature threshold
- DUAL ALERTS: Audible and visual warnings with a buzzer and dash-mounted LED panel
- Alerts will continue until the temperature falls and stays below the threshold for a set amount of time
- Includes Intermittent Fault Filter™ (IFF) technology to eliminate false readings

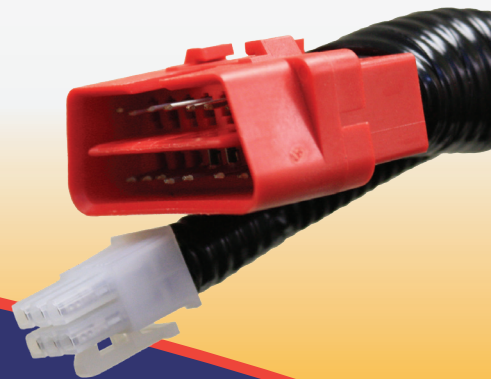

Proudly distributed by

**LGS GROUP**  
AUTOMOTIVE TECHNOLOGIES

**(775) 831-2002**

# Details

Features may vary by make, model or year.  
See instructions for complete details.

## EXAMPLE SCHEMATIC

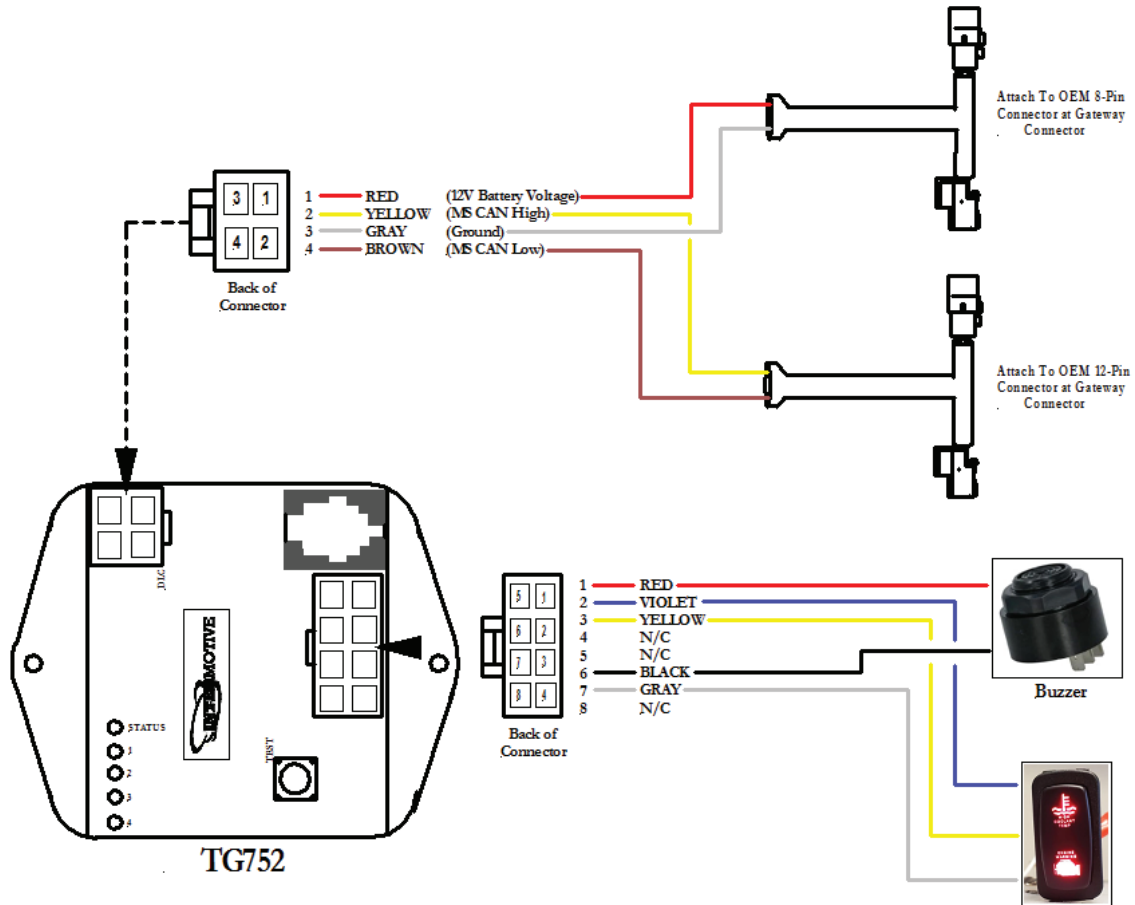

## SPECIFICATIONS

Number of Inputs                      Power and ground inputs

Number of Outputs                    Five outputs; three for LED panel and two for buzzer

Current Draw                            80 mA

Quiescent Draw                        < 2 mA (sleep current)

Temperature Range                    -40°C to 80°C

Dimensions                              3" L x 2" W x 1" H