

**Speed Sentinel**

**INTERMOTIVE**  
**VEHICLE**  
**CONTROLS**

An ISO 9001:2015 Registered Company

# Speed Sentinel™

## Road Speed Limiter

### Overview

- Field programmable device that prevents vehicles from being driven at unsafe speeds
- Maximum speeds can be set from 10-80 mph in single mph increments
- Simple plug and play connections

#### SPEEDING STATISTICS

- Every 5 mph a vehicle travels over 60 mph reduces fuel economy by 7 percent
- In major studies, speeding is the No. 1 factor in traffic fatalities and nearly triples the odds of an accident

### Features

- **INCREASED FUEL SAVINGS:** Can save as much as \$0.21/gallon in effective fuel costs (speeding increases fuel usage)
- Does not limit the engine output below the maximum speed setting
- Multi-mode: Single or dual speed, Forward/Reverse max speed
- Includes passing mode, emergency response override and theft deterrent mode
- Includes Intermittent Fault Filter™ (IFF) technology to eliminate false readings

*Product features may vary by make, model or year. See instructions for complete details.*

Proudly distributed by  
**LGS GROUP**  
AUTOMOTIVE TECHNOLOGIES

**(775) 831-2002**

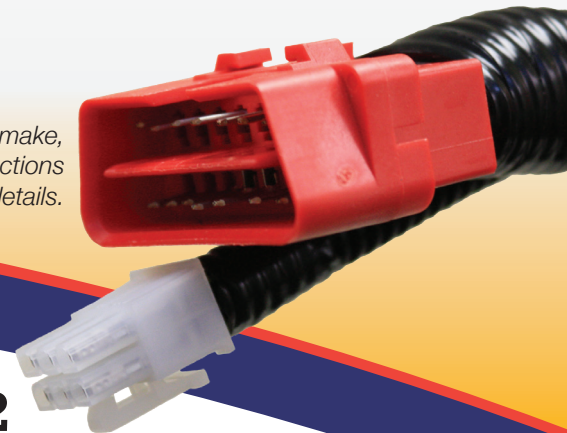

# Details

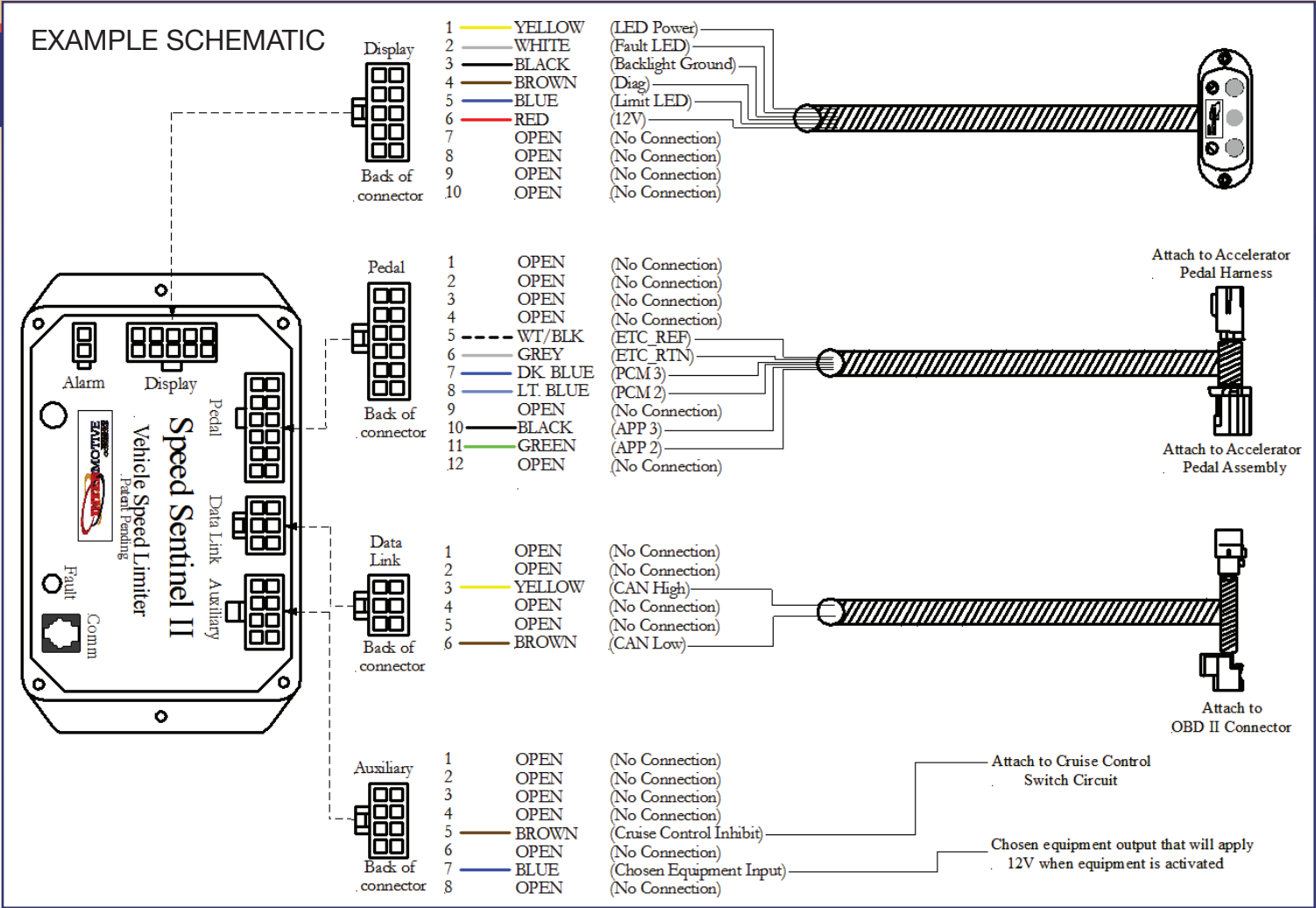

## SPECIFICATIONS

Number of Inputs	Two user inputs
Number of Outputs	One user output
Current Draw	75-85 mA
Quiescent Draw	0.5 mA (sleep current)
Temperature Range	-40°C to 80°C
Dimensions	5" L x 3" W x 1.25" H