

**Protected Idle
Output**

INTERMOTIVE
**VEHICLE
CONTROLS**

An ISO 9001:2015 Registered Company

Protected Idle Output

Anti-theft Lock for Weapons Rack & Hatch

Overview

- Automatically disables the weapons rack and hatch on a GM Tahoe PPV while the Protected Idle™ feature is engaged
- Offers an extra layer of lockdown when working outside the vehicle
- Simple plug and play connections

Features

- Prevents unauthorized access to the gun lock and rear hatch when the OEM feature (idling shift lock with fob) activates; instantly unlocks when Protected Idle™ disengages
- Output installs in minutes; no cutting of factory wires
- Designed specifically for the GM Tahoe and available for 2021-current model year

See instructions for complete details.

Proudly distributed by



(775) 831-2002

Details

EXAMPLE SCHEMATIC

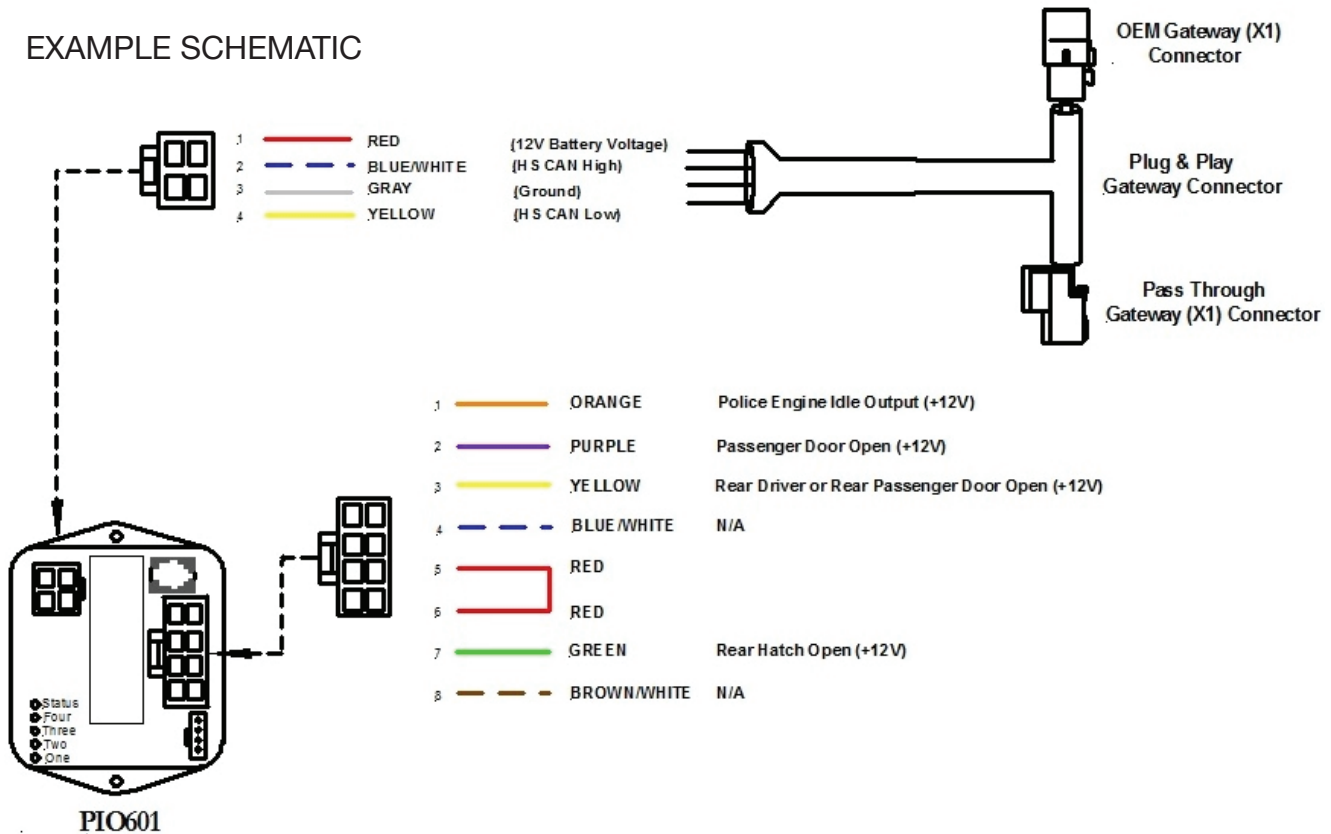

SPECIFICATIONS

Number of Inputs	None
Number of Outputs	Four (two +12V, two ground)
Current Draw	~ 100 mA
Quiescent Draw	~ 2 mA (sleep current)
CAN Speed	High speed
Temperature Range	-40°C to 80°C
Dimensions	3" L x 2" W x 1" H