

## **ILISP510-B Shift Interlock** **2009-2018 Ford E Series** **Contact InterMotive for specific applications**

### **Introduction**

The ILISP510-B is a wheelchair lift safety interlock which will work with the key on or key off. It will enable the lift when certain vehicle safety conditions are met, and will lock the transmission shifter in Park when the lift is in use (not stowed). Optional Plug & Play harnesses are available for most applications which makes the installation fast and easy.



### **Installation Instructions**

**Disconnect vehicle battery before proceeding with installation.**



#### **WARNING**

Disconnect the battery to prevent setting a check engine light.

### **IMPORTANT—READ BEFORE INSTALLATION**

It is the installer's responsibility to route and secure all wiring harnesses where they cannot be damaged by sharp objects, mechanical moving parts and high heat sources. Failure to do so could result in damage to the system or vehicle and create possible safety concerns for the operator and passengers.

Avoid placing the module where it could encounter strong magnetic fields from high current cabling connected to motors, solenoids, etc. Avoid radio frequency energy from antennas or inverters next to the module. Avoid high voltage spikes in vehicle wiring by always using diode clamped relays when installing upfitter circuits.

### **CAUTION**

All electronic products are susceptible to damage from Electrostatic Discharge or ESD. Ground yourself before handling or working with the module and harnessing by first touching chassis ground, such as the barrel of the cigarette lighter.



### **ILISP510 Module**

Remove the lower dash panel below the steering column area and find a suitable location to mount the module so that the Diagnostic LED's can be viewed with the lower dash panel removed. Locate the module in an area away from any high external heat sources (engine heat, heater ducts, etc.). Do not actually mount the module until all wire harnesses are routed and secure. The last step of the installation is to mount the module.

## Data Link Harness

1. Locate the vehicle OBDII Data Link Connector, mounted below the lower left dash panel.
2. Remove the mounting screws for the OBDII connector. Plug the red connector from the ILISP510-B Data Link Harness into the vehicle's OBDII connector. Ensure the connection is fully seated and secure with the supplied wire tie.
3. Mount the Black pass through connector from the ILISP510-B Data Link Harness in the former location of the vehicle's OBDII connector.
4. Secure the ILISP510-B Data Link harness so that it does not hang below the lower dash panel.
5. Plug the free end of the Data Link harness into the mating 4-pin connector on the ILISP510-B module.

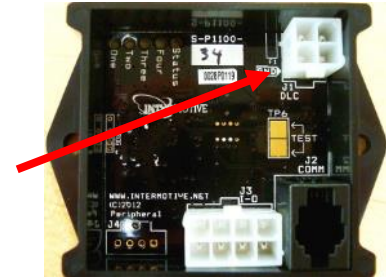

## LED Display Panel Mounting - Black 4-pin connector

Locate a suitable position on the dashboard, within view of the driver to mount the LED Display Panel. Ensure that there is open space behind the dash where the panel is mounted. The harness is 40" in length, which is the maximum distance the display can be from the module.

1. Drill a 5/8" hole in the dash where the center of the display will be located.
2. Attach the Black 4-pin connector of the LED Display Panel Harness to the module.
3. Run the other end of the harness under the dash and out through the 5/8" hole.
4. Attach the end to the LED Display Panel. Ensure the panel is level and secure using supplied screws.

## Lift Connections - 8-pin module connector—Optional Plug & Play Lift Harness for Braun lifts

1. Plug the 8 pin connector into the ILISP510-B module.
2. Run the lift harness out to the lift and plug it into the appropriate lift connector:
  - Braun models 9-Pin connector

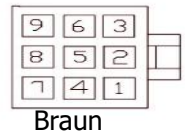

If the harness includes a control relay integrated into the harness, peel off the 2-sided tape and stick to the lift housing. Skip to the Park Brake Connection section.

## Park Brake Connection

**Plug & Play Park Brake Harness** - Disconnect the OEM connector from the Park Brake Switch. Plug in the Park Brake T-Harness, and plug in the OEM connector also into the T" harness.

## Lift Connections - 8-pin module connector—Blunt Cut Lift Harness for Braun lifts

The ILISP510-B provides three ground side inputs and one 12V, 1/2 amp output.

If a control relay is needed to power the lift (lift draws more than 1/2A), a standard rectifier diode (Digikey RL202-TPCT-ND or equivalent), **must** be installed between pins 85 & 87 of the relay, as shown in the ILISP510-B CAD Blunt Cut drawing.

The following three wires will need to be lengthened, using solder and heat shrink or tape. The blunt-cut (4-wire) harness provides for control connections to the lift as follows:

**Orange** - This Vehicle Secure output provides 12V @ 1/2 amp when it is safe to operate the lift and is to be connected to the lift.

- **Braun Lift:** Connect to pin #6 of the 9-pin lift adapter connector.

**Gray** - Connect this input to the Lift Stowed Switch. It must have a ground signal with the lift stowed. When lift is not stowed, the vehicle is prevented from shifting out of Park.

- **Braun Lift:** Connect to pin #9 of the 9-pin lift adapter connector.

**White - Braun Lift:** Connect the White wire (Lift wake up (GND) input to pin #1 of the 9 pin lift adapter connector.

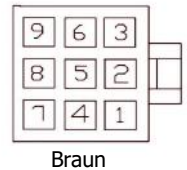

### Park Brake Connection

**Brown wire** - This input connects to the OEM Park Brake switch. Install a standard rectifier diode (Digikey RL202-TPCT-ND or equivalent), as shown in the Blunt Cut CAD Drawing, to isolate the Park Brake ground signal. Strip back some insulation off the WT/VT wire, solder the Brown wire on and tape or use heat shrink tubing.

- Pin #1 - N/C
- Pin #2 - N/C
- Pin #3 - GREEN (Vehicle Secure (12V) Output)
- Pin #4 - WHITE (Wake-up Signal (GND) input)
- Pin #5 - BROWN (Park Brake (GND) Input)
- Pin #6 - N/C
- Pin #7 - GREEN (From Pin #3)
- Pin #8 - GRAY (Lift Stowed (GND) Input)



### Connect the 8 pin connector to the module

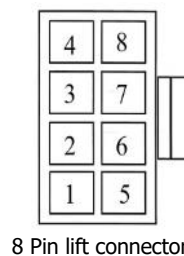

**\*\* Optional Braun Plug & Play Relay Kit #840-00015 \*\***

Current models of Braun lifts draw more than 1 amp and will require the Braun plug and play relay kit.

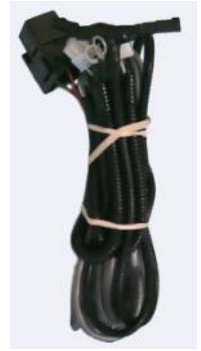

**Green Wire (from relay)** - Connect to pin #6 of the 9-pin lift adapter connector.

**Black** - Connect this input to the Lift Stowed Switch. It must have a ground signal with the lift stowed. When lift is not stowed, the vehicle is prevented from shifting out of Park. Connect to pin #9 of the 9-pin lift adapter connector.

**White** - Connect the White wire (Lift wake up (GND) input to pin #1 of the 9 pin lift adapter connector.

**Brown** (eyelet) - Connect to External ground at the lift.

**Red** (eyelet) - Connect to External +12V at the lift.



**Braun Lift Connector**

**Brown** - Plug & Play Park Brake Harness - Disconnect the OEM connector from the Park Brake Switch. Plug in the Park Brake T-Harness, and plug in the OEM connector also into the T" harness.

**ILISP510 Module**

Ensure all the harnesses are properly connected and routed, and are not hanging below the dash area. Mount the ILISP510 module as described on page one. Secure using screws or doubled sided tape.

**Reconnect vehicle battery**

## Post Installation / Check List

### ILISP510-B (Electric Lift Door)

The following checks must be made after installation of the system, to ensure correct and safe operation of the lift. If any of the checks do not pass, do not deliver the vehicle. Recheck all connections as per the installation instructions

Begin the checklist with the vehicle in the following state:

- Lift Stowed
- Lift Door closed
- Park Brake set (PB)
- Transmission in Park (P)
- Ignition off (Key off). Wait until the module goes into "Sleep" mode (all panel LEDs OFF) which takes approximately 5 minutes.

1. Press the Lift Deploy Request button on the remote fob (electric door), or open door and press button on pendant (manual door). Verify the module wakes up and all 5 LED's illuminate for approximately 2 seconds. The lower icon LEDs are backlit and will remain illuminated whenever the module is awake. The fob button may have to be held for 2 seconds or more to wake up the system.



Vehicle Secure/Lift Enable, Lift Deployed, Park Brake, Park, Shift Lock

2. Turn the ignition key on.
3. With Lift Door open, Park Brake set and transmission in Park, all LED's except Lift Deployed will be illuminated. Attempt to deploy the lift. Verify the lift deploys and all 5 LED's are illuminated.
4. With the Lift deployed and Service Brake applied, verify the vehicle cannot be shifted out of Park
5. Stow the lift but leave door open.
6. With Lift Door open, Lift Stowed, transmission in Park, release Park Brake. Verify that the Park Brake LED goes out. Attempt to deploy the lift. Verify the lift does not deploy with Park Brake released.
7. With lift door open, Park Brake set, lift stowed, Transmission in Neutral, verify the lift does not deploy.
8. With key on. Lift Door closed, Park Brake released and the Service Brake applied, verify the transmission shift level will shift out of Park

**Note:** The factory default is for the module to enable the lift on wake up (firmware 2.02 and later). This may cause the lift to beep, etc., whenever the vehicle doors are opened. To change this behavior, see ILISP510-B Application note ([www.intermotive.net](http://www.intermotive.net)).

**Confirmation Signal- (2009 and onward model year vehicles)** The vehicle lamps and radio will cycle briefly when the ignition is on and the lift door is initially closed. This signal is sent from the Ford PCM.

**If any of the previous Post Installation tests fail, enter diagnostic mode.**

## Post Installation / Check List

**Lift Interlock Diagnostic Mode Testing** allows a visual indication of system status and is a good troubleshooting tool when used in conjunction with the above tests. The module is fully functional in this mode. Enter Diagnostic Mode by the following steps:

1. Place transmission in Park and turn ignition switch to run position.
  2. Momentarily short the two Gold "Test" pads together on the module. LED's on the module will prove out, then become status indicators:
- LED 1 will be on when Shift Lock enabled.
  - LED 2 will be on when transmission is in Park.
  - LED 3 will be on when Park Brake is set.
  - LED 4 will be on when the lift is deployed.
  - LED marked "status" indicates "Vehicle Secure" or "Lift enabled," meaning there is 12V on Pin 3 (Vehicle Secure wire), which connects to the lift.
  - Cycling the key will exit Diagnostic Mode and all LED's will be off.

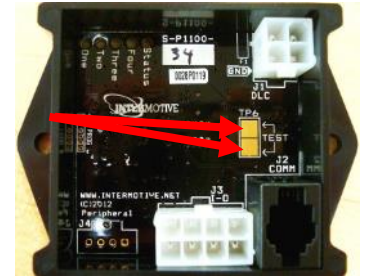

## Leave in vehicle Operating Instructions ILISP510-B Shift Interlock (Electric Lift Door) 2009-2018 Ford E Series

### ILISP510-B Lift Interlock

The ILISP510-B is a wheelchair lift safety interlock which will work with the key on or key off. It will enable the lift when certain vehicle safety conditions are met, and will lock the transmission shifter in Park when the wheelchair lift is in use (not stowed). Optional Plug & Play harnesses are available for most applications which makes the installation fast and easy.

#### Key On function:

1. The system will wake up when the fob or pendant deploy buttons are pushed.
2. With the module awake and the vehicle in Park, the (P) LED will be illuminated.
3. When the Park Brake is applied, the (PB) LED will be illuminated.
4. When the Lift is deployed, the Lift Deployed LED will be illuminated.
5. With the Park Brake applied, the PB, P, Shift Lock, and Vehicle Secure LED's will be illuminated, and the lift will be operational (enabled).

**Key Off function:** (if optional Park Brake input supplied)

- Vehicle must be in Park before turning key off.
- With the vehicle in Park and the Park Brake applied, the (P), (PB), and Vehicle Secure LED's will be on.
- When the lift starts to deploy, the Shift Lock and Lift Deployed LEDs will illuminate.



When the lift is stowed and ignition power is not present for 5 minutes, the system will enter a low current "sleep" mode of operation. To wake from "sleep" mode, turn the ignition on (key on) or press the lift deploy button on the pendant or fob (may have to be depressed for a second or two to wake the system). All display LEDs will illuminate for approximately 2 seconds as a "prove out". The backlit LEDs will remain on as long as the module is awake.

**Note:** If the vehicle has Daytime Running Lights they will be activated when the Lift Door is open and/or the Park Brake is on and the Ignition Key is on.

**Confirmation Signal- (2009 and onward model year vehicles)** The vehicle lamps and radio will cycle briefly when the ignition is on and the lift door is initially closed. This signal is sent from the Ford PCM.

**Note:** Do not leave the lift deployed when the vehicle is not in use. This will cause a current draw on the vehicle's electrical system and could result in a dead battery.

# Blunt Cut Harness with Relay

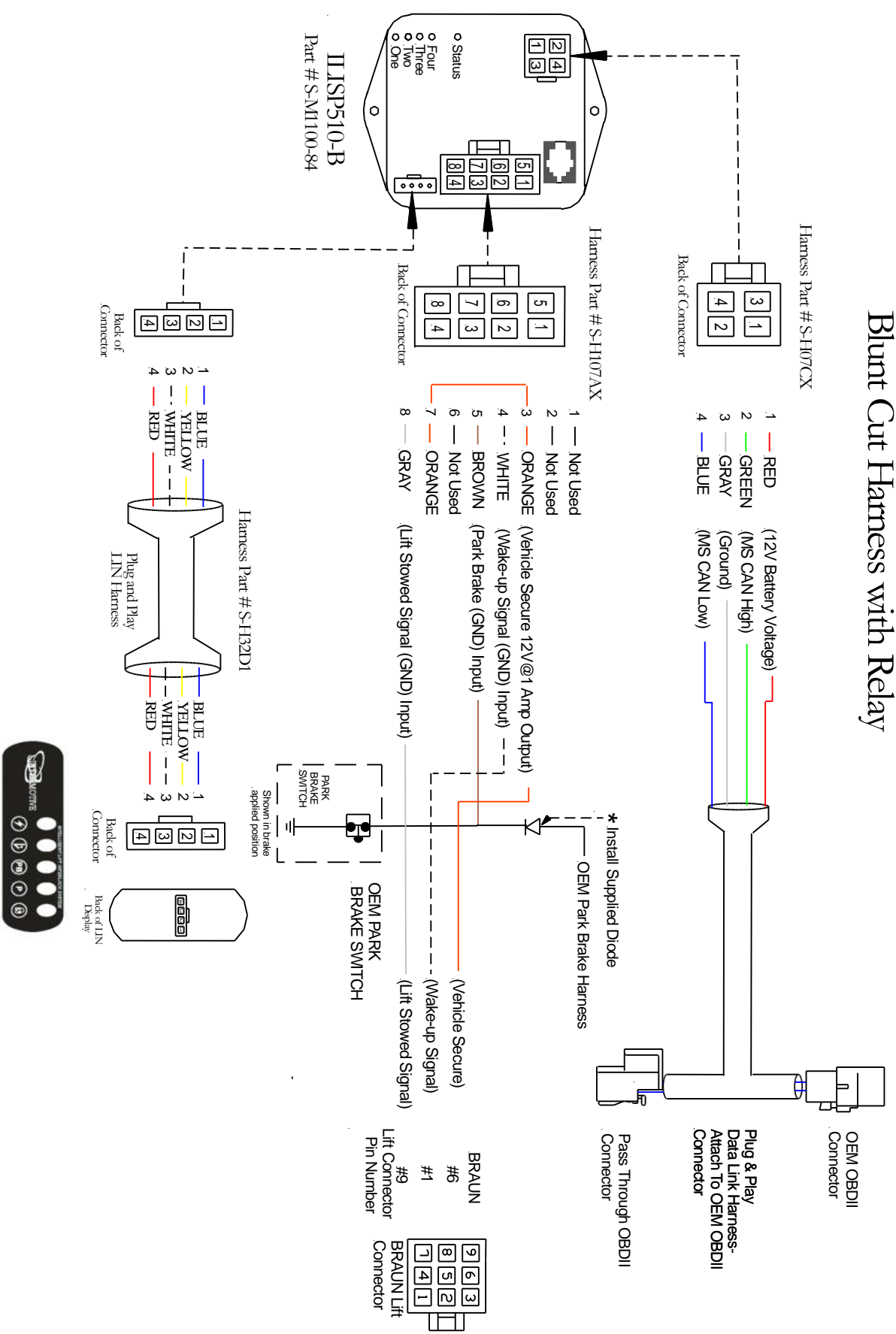

If the ILISP510-B fails any step in the Post Installation Test, review the installation instructions and check all connections. If necessary, call InterMotive Technical Support at (530) 823-1048.



# BRAUN Plug and Play Harness with Relay

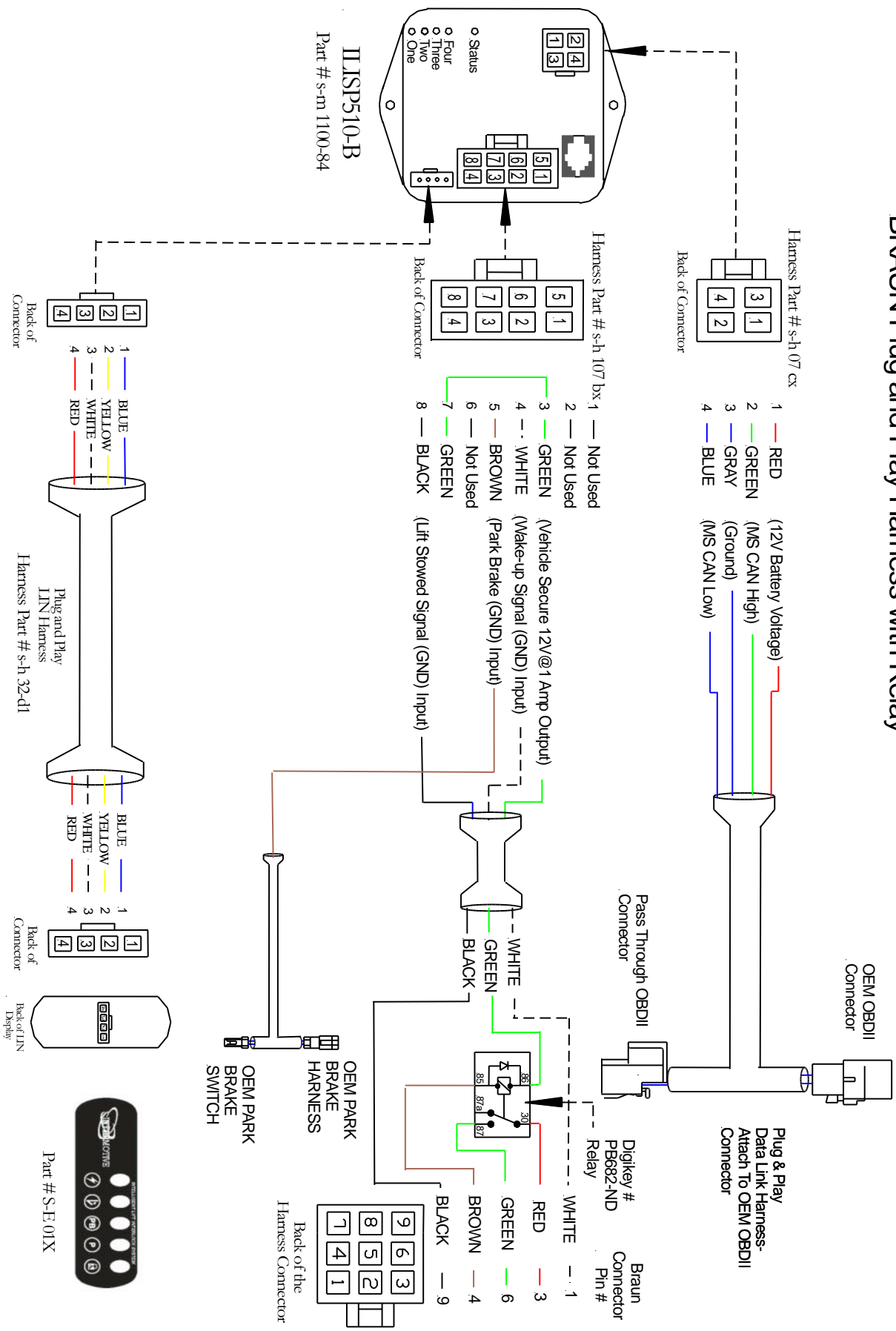

If the ILISP510-B fails any step in the Post Installation Test, review the installation instructions and check all connections. If necessary call InterMotive Technical Support at (530) 823-1048.

## 2019 BRAUN Plug and Play Harness with Relay

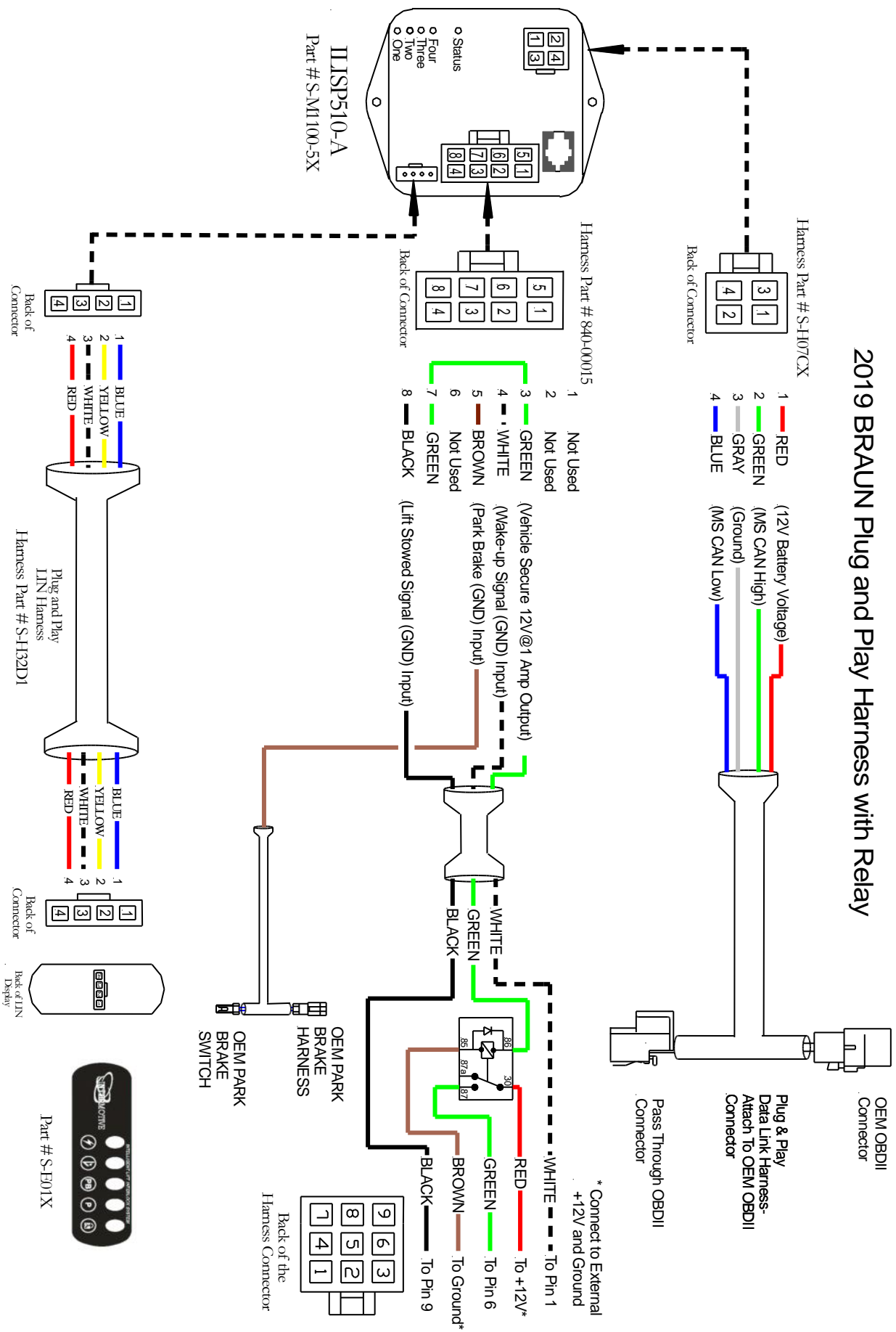

If the ILISP510-B fails any step in the Post Installation Test, review the installation instructions and check all connections.  
 If necessary, call InterMotive Technical Support at (530) 823-1048.