

HAWK6-401

Reverse Assistance System



Introduction

The HAWK6-401 Reverse Assistance System is an ultrasonic distance monitoring system. When the vehicle is in reverse, the HAWK6-401 electronically detects the area behind the vehicle and alerts the driver with an audible tone and a digital display if any objects are detected. HAWK6-401 is designed to detect objects which can reflect ultrasonic sound waves such as walls, vehicles, and poles.

Installation Instructions

Disconnect vehicle battery before proceeding with installation.



WARNING

Disconnect the battery to prevent setting a check engine light.

IMPORTANT—READ BEFORE INSTALLATION

It is the installer's responsibility to route and secure all wiring harnesses where they cannot be damaged by sharp objects, mechanical moving parts and high heat sources. Failure to do so could result in damage to the system or vehicle and create possible safety concerns for the operator and passengers.

Avoid placing the module where it could encounter strong magnetic fields from high current cabling connected to motors, solenoids, etc. Avoid radio frequency energy from antennas or inverters next to the module. Avoid high voltage spikes in vehicle wiring by always using diode clamped relays when installing upfitter circuits.

Note: Excess cabling for the HAWK6-401 system should be rolled up and located away from other vehicle electronics. Split this roll into roughly two equal coils and overlay them one on top of the other, such that the current flow changes direction from one coil to the next. This will minimize the inductive effects of coiling the wire, and will minimize possible interference with other vehicle electronics.

To aid in installation, first gain access to the connection points. Remove any interior panels covering the left (driver) side of the rear cap and along the upper left side of the vehicle all the way to the front of the vehicle. It is not necessary to cut any OEM wires during the installation of the HAWK6-401 wire harness.

Lower Sensors and In-Bumper Harness

The procedure for positioning and mounting the sensors depends on the shape of the rear bumper. The sensors must be mounted on a flat surface of the bumper (curved surfaces must not exceed 5°). Sensor height must be 17 - 24 inches from the ground or the sensors will not work properly.

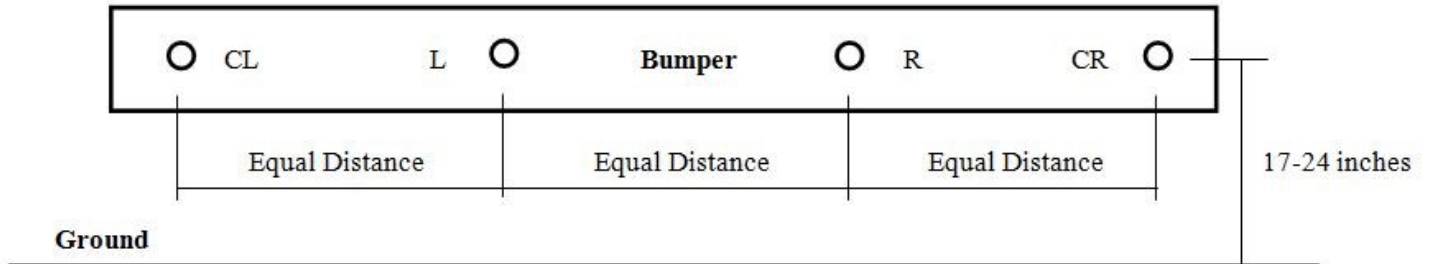

NOTE: The preset of the sensitivity for the sensor heights is 17 inches above the ground. To avoid false alarm, sensor height must be at least 17 inches.

1. Measure horizontally from each corner of the bumper and mark a distance of 6 - 8 inches for both corner sensors.
2. Divide the remaining distance by 3 and mark the two center sensor locations such that the distance between each sensor is equal.
3. Drill four 1-inch holes (use a 1-inch hole saw) in the bumper through the previous marks.
4. Install the four sensors through the holes in their proper location.

THE SENSORS MUST BE INSTALLED WITH THE DOT POINTING DOWN.



In-Vehicle Harness – The In-Vehicle Harness connects the Bumper/Sensor Harness to the Control Unit in the vehicle.

1. Connect the 8-pin connector on the In-Vehicle Harness to the connector located on the bumper.
2. Drill a 5/8" hole in the bottom of the rear of the vehicle.
3. Route the harness through the hole and seat the harness grommet securely in the hole.
4. Connect the 8 pin connector to the mating cavity on the module labeled "Sensor1".
5. Secure the harness as needed.

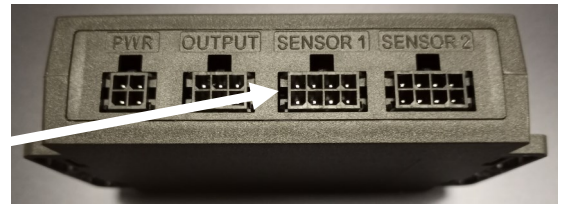

Rear Top Sensor Harness

1. Install the 2 additional sensors in their proper location.
2. Plug the Rear Top Sensor Harness into the 8-pin connector labeled "Sensor2" on the Hawkeye module.

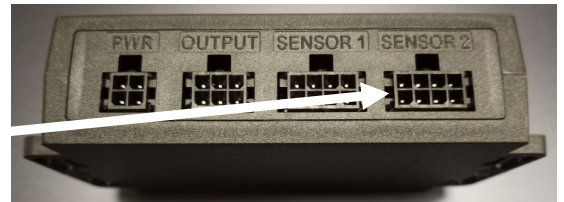

Control Module

The control module must be located inside of the vehicle on the left-hand (driver) side. Attach the control module inside of the vehicle within 4 feet of the rear tail-lamp assembly. The control module should be attached in a vertical position to prevent water from getting into the module.

Control Module DIP Switches

- Open the control module **right** cover using a screwdriver.

The default setting is switches

1 = OFF
2 = ON
3 = OFF

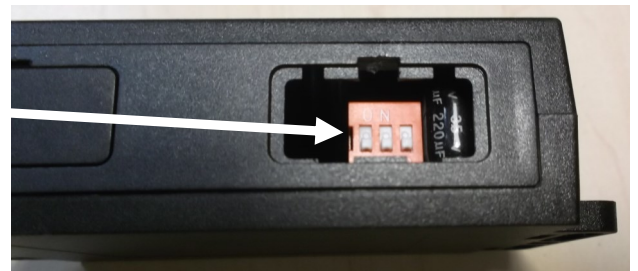

LED Display Panel

The LED display panel provides system feedback to the driver. Prior to installing the panel, determine if any changes to the default settings are desired (See figure 1).

LED Display Pane DIP Switch

The default setting is switches 1-6 are 'On' and switches 7-8 are 'Off'.

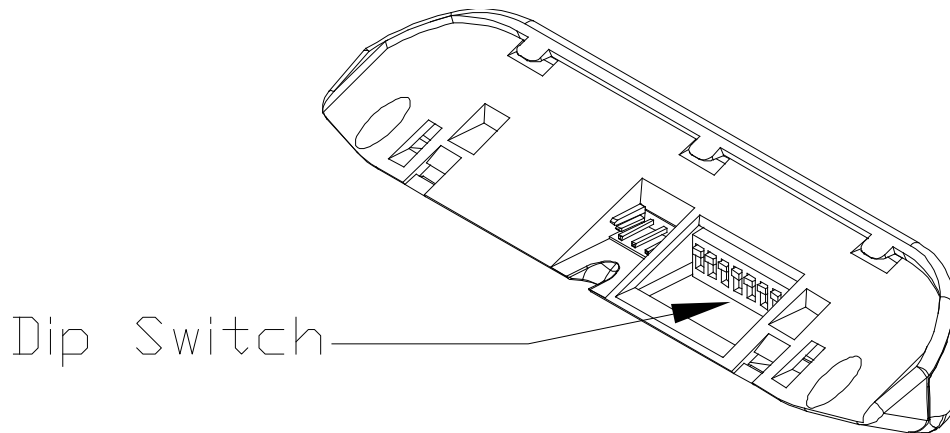

Dip Switch	Function	Note
1	Power	Must be ON
2	Data	Must be ON
3	Buzzer	ON = activate buzzer OFF = no buzzer sound
4	Buzzer Volume 1	ON = louder OFF = does not affect the loudness of buzzer volume
5	Buzzer Volume 2	ON and Dip Switch 4 ON = loudest OFF = does not affect the loudness of buzzer volume
6	Feet/Meter	ON = Feet OFF = Meter
7	LED Bar Display Swap	ON = to swap the LED bar display for LEFT/RIGHT sensor indicator when the display is installed upside down
8	Number Display Rotation	ON = to invert the displayed number when the display is installed upside down

(Figure 1)

Note: If mounting the LED panel in an inverted position, switches 7 and 8 must **both** be switched to 'On' for proper readout.

1. Using 2 of the supplied screws (different types are provided, but only 2 are needed), secure the display bracket (figure 2a or 2b), then attach the display to the bracket. If desired, drill a hole through the dash to route the display wire harness.
2. Run the display wire harness along the left (driver) side to the back of the vehicle.
3. Connect the White 3-pin connector to the proper opening on the display panel. Make sure the connector is fully seated.
4. Secure the harness along the left side of the coach.
5. Connect the Black 6-pin connector to the mating cavity on the module labeled "Output".

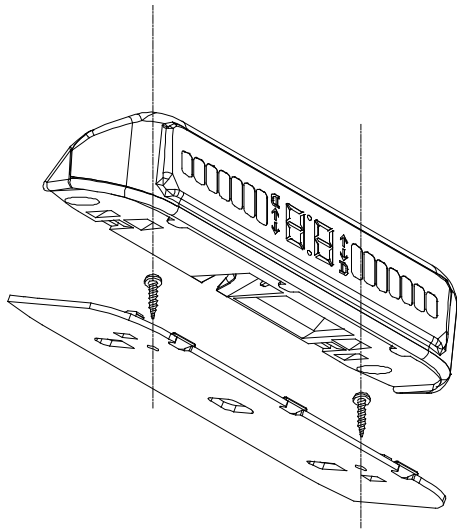

(Figure 2a - Normal Position)

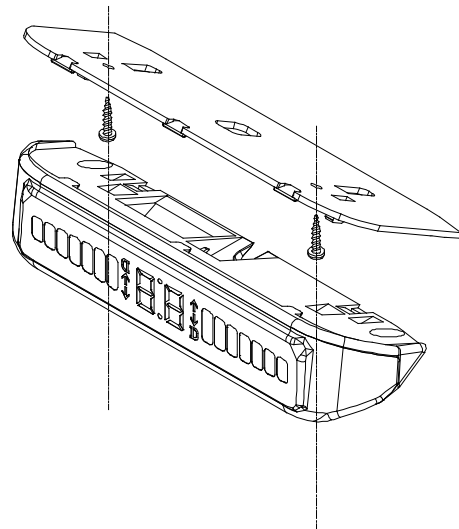

(Figure 2b - Inverted Position)

Reconnect Vehicle Battery

Post Installation

The following checks must be made after installation of the system. If any of the checks do not pass, do not deliver the vehicle. Recheck all connections as per the installation instructions.

Important: Ensure no objects are present within 10 feet of the bumper while testing.

1. **Verify that the Park Brake is firmly set with the Engine Off and wheels blocked.** Turn the ignition key to "ACC" position and place the transmission in reverse. The display indicator should activate and produce a single audible beep.
2. With the aid of an assistant, verify that the sensors are connected into the proper openings on the bumper:
 - 2.1 Use a cloth to cover the two middle sensors. Holding a flat dense object (5" x 20"), approach the passenger side corner sensor from approximately 10 feet away. Verify that the LED Display shows proper distance and orientation. Repeat procedure for the driver side corner sensor.
 - 2.2 Remove covers from the middle sensors and block the corner sensors. Repeat procedure as in 2.1. Verify that the LED Display shows proper distance and orientation.
3. If the system gives a warning without an object in the proper zone (false alarm):
 - 3.1 Check for proper sensor installation and orientation (dot on sensor must be facing down).
 - 3.2 The sensors may be detecting the ground. Note: The preset of the sensitivity for the sensor height is 17 inches above the ground. To avoid false alarm, sensor height must be at least 17 inches. If sensor height is correct, adjust sensitivity (see next page).

System Self Test

Immediately after the system powers up (when vehicle is shifted into reverse), it will do a sensor self test. If a sensor circuit is malfunctioning, or a sensor is disconnected, the corresponding sensor will be displayed briefly on the LED display. On the bumper, the outermost sensor on the driver side is sensor #1, then proceeding towards the passenger side, #2, #3, and finally #4 which is the outermost sensor on the passenger side of the bumper. The upper sensors will display #5 and #6 if malfunctioning or if a sensor is disconnected.

Guide to Adjust System Sensitivity

1. Open the control module **left** cover using a screwdriver.
2. Use a cart or other mobile object with a piece of 3/4" plywood (18" x 24") on the side facing the sensors (figure 3). A dense material is required to reflect the ultrasonic waves.
3. Position the cart in the direct path of a sensor at the distance of 5 feet.
4. Insert a small screwdriver into the **right** potentiometer and gently turn the potentiometer clockwise to the stopping point.



(figure 3)

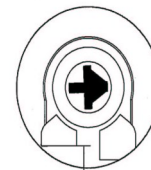
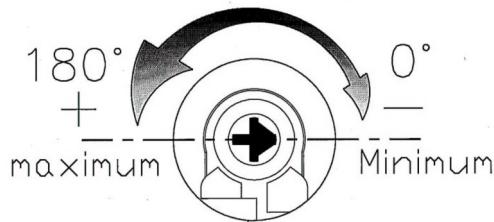
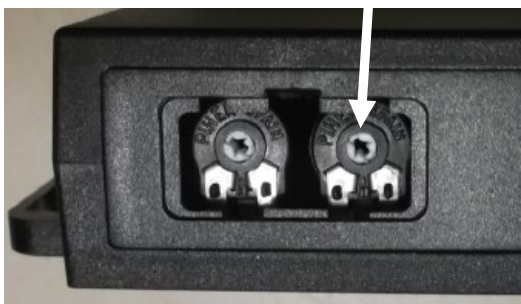

Minimum sensitivity adjustment



Maximum sensitivity adjustment

5. With the **Engine Off, set the Park Brake, block the wheels, and place the transmission in reverse.** The display panel should now have a blank reading.
6. Slowly turn the **right** potentiometer counter-clockwise until the display gives a numerical reading of the distance of the cart and has a consistent audible sound.
7. Reset the module by placing the vehicle in Park or by unplugging the module power connector. Removing the power from the module allows the module to recognize the new sensitivity adjustment.
8. Place vehicle in reverse or reinstall the module power connector. Move the cart away from the bus and note the display readings. Move the cart forward, measure the cart distance and compare the distance with the display reading.
9. Adjust the sensitivity further if needed. Turning the potentiometer clockwise reduces the sensitivity and turning the potentiometer counter-clockwise increases sensitivity. Repeat Post-Installation Testing. If necessary, readjust and retest.
10. Replace cover on the back of the control module.

Reading the HAWK6-401 Display

- The center of the display will show the distance of detected objects.
- Each side of the display has illuminated bars, which indicate the side and distance of the detected object.
- As the detected object becomes closer, more bars will illuminate and an audible beep will alert the driver.
- The audible beeps will increase in tempo as the detected object becomes closer.
- The audible sound will become a constant noise when the detected object is in range of a collision.

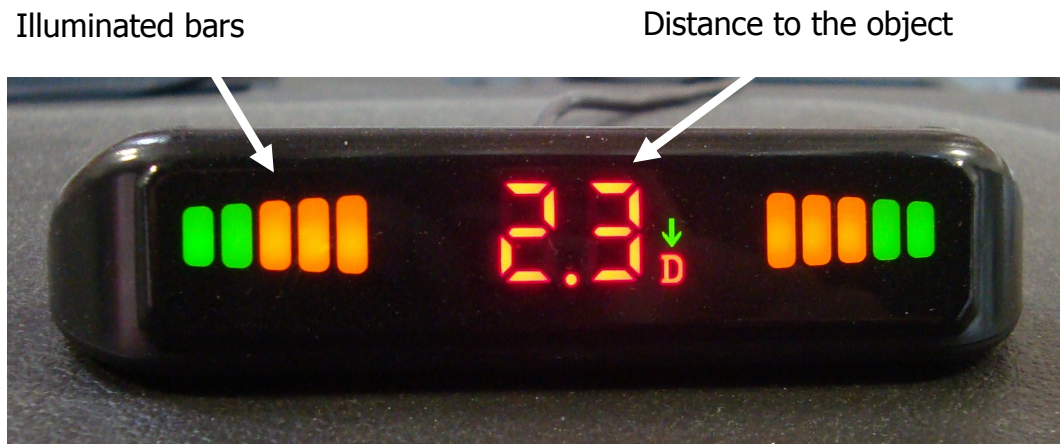

CAUTION!

This system is not designed to prevent contact with small or moving objects. This system is designed to provide a warning to assist the driver in detecting large stationary objects when moving in reverse at "parking speeds" of approximately 4 mph. The HAWK Reverse Assistance System may have reduced performance or be activated in inclement weather.

To help avoid personal injury, always use caution when in reverse and when using the HAWK Reverse Assistance System.

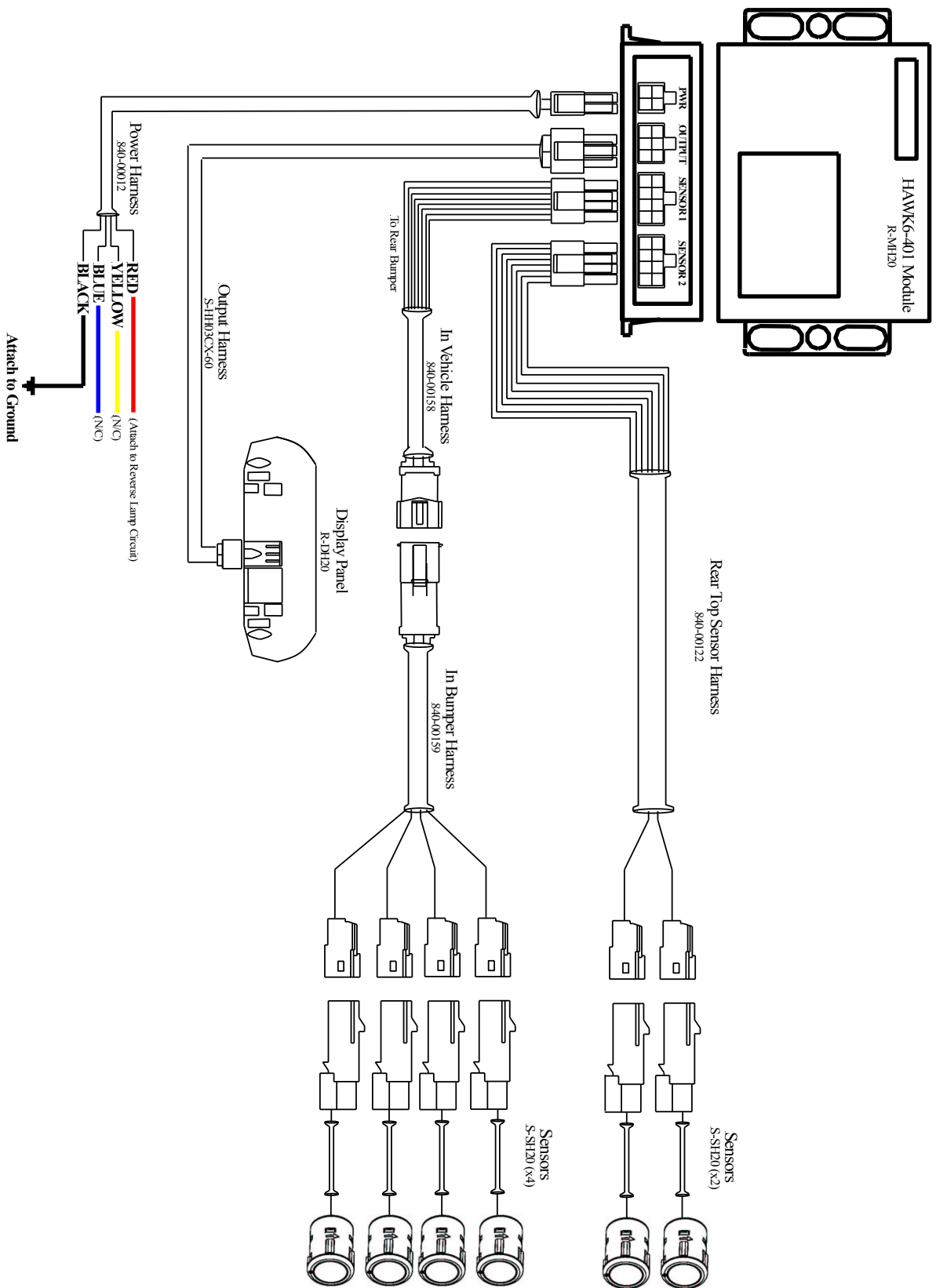

Submit product registration at www.intermotive.net

If the HAWK6-401 fails any step in the Post Installation Test, review the installation instructions and check all connections. If necessary, call

InterMotive Technical Support at (530) 823-1048.

HAWK6-401-040722