

## **HAWK4-401 Reverse Assistance System**

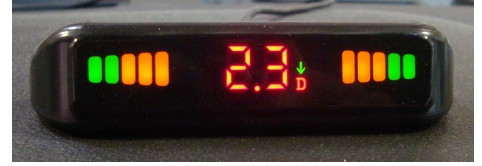

### **Introduction**

The HAWK4-401 Reverse Assistance System is an ultrasonic distance monitoring system. When the vehicle is in reverse, the HAWK4-401 electronically detects the area behind the vehicle and alerts the driver with an audible tone and a digital display if any objects are detected. HAWK4-401 is designed to detect objects which can reflect ultrasonic sound waves such as walls, vehicles, and poles.

### **Installation Instructions**

**Disconnect vehicle battery before proceeding with installation.**



#### **WARNING**

Disconnect the battery to prevent setting a check engine light.

### **IMPORTANT—READ BEFORE INSTALLATION**

It is the installer's responsibility to route and secure all wiring harnesses where they cannot be damaged by sharp objects, mechanical moving parts and high heat sources. Failure to do so could result in damage to the system or vehicle and create possible safety concerns for the operator and passengers.

Avoid placing the module where it could encounter strong magnetic fields from high current cabling connected to motors, solenoids, etc. Avoid radio frequency energy from antennas or inverters next to the module. Avoid high voltage spikes in vehicle wiring by always using diode clamped relays when installing upfitter circuits.

**Note:** Excess cabling for the HAWK4-401 system should be rolled up and located away from other vehicle electronics. Split this roll into roughly two equal coils and overlay them one on top of the other, such that the current flow changes direction from one coil to the next. This will minimize the inductive effects of coiling the wire, and will minimize possible interference with other vehicle electronics.

To aid in installation, first gain access to the connection points. Remove any interior panels covering the left (driver) side of the rear cap and along the upper left side of the vehicle all the way to the front of the vehicle. It is not necessary to cut any OEM wires during the installation of the HAWK4-401 wire harness.

## Sensors and In-Bumper Harness

The procedure for positioning and mounting the sensors depends on the shape of the rear bumper. The sensors must be mounted on a flat surface of the bumper (curved surfaces must not exceed 5°). Sensor height must be 17 - 24 inches from the ground or the sensors will not work properly.

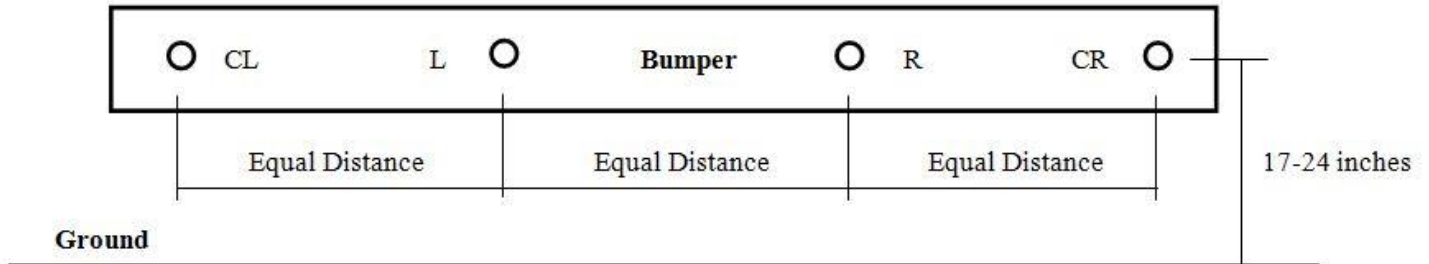

**NOTE: The preset of the sensitivity for the sensor heights is 17 inches above the ground. To avoid false alarm, sensor height must be at least 17 inches.**

1. Measure horizontally from each corner of the bumper and mark a distance of 6 - 8 inches for both corner sensors.
2. Divide the remaining distance by 3 and mark the two center sensor locations such that the distance between each sensor is equal.
3. Drill four 1-inch holes (use a 1-inch hole saw) in the bumper through the previous marks.
4. Install the four sensors through the holes in their proper location.

THE SENSORS MUST BE INSTALLED WITH THE DOT POINTING DOWN.



**In-Vehicle Harness** – The In-Vehicle Harness connects the Bumper/Sensor Harness to the Control Unit in the vehicle.

1. Connect the 8-pin connector on the In-Vehicle Harness to the connector located on the bumper.
2. Drill a 5/8" hole in the bottom of the rear of the vehicle.
3. Route the harness through the hole and seat the harness grommet securely in the hole.
4. Connect the 8 pin connector to the mating cavity on the module labeled "Sensor1".
5. Secure the harness as needed.

**Control Module**

The control module must be located inside of the vehicle on the left-hand (driver) side. Attach the control module inside of the vehicle within 4 feet of the rear tail-lamp assembly. The control module should be attached in a vertical position to prevent water from getting into the module.

**Control Module DIP Switches**

- Open the control module **right** cover using a screwdriver.
- The default setting is switches 1-3 are Off.



	Sensor 1	Sensor 2	Sensor 3	Sensor 4	DIP Switch Setting		
					1	2	3
Type A	9.9 Feet	9.9 Feet	9.9 Feet	9.9 Feet	OFF	OFF	OFF
Type B	7.0 Feet	7.0 Feet	7.0 Feet	7.0 Feet	OFF	OFF	ON
Type C	7.0 Feet	9.9 Feet	9.9 Feet	7.0 Feet	OFF	ON	OFF
Type D	5.5 Feet	7.0 Feet	7.0 Feet	5.5 Feet	OFF	ON	ON
Type E	9.9 Feet	9.9 Feet	9.9 Feet	9.9 Feet	ON	OFF	OFF
Type F	7.0 Feet	7.0 Feet	7.0 Feet	7.0 Feet	ON	OFF	ON
Type G	7.0 Feet	9.9 Feet	9.9 Feet	7.0 Feet	ON	ON	OFF
Type H	5.5 Feet	7.0 Feet	7.0 Feet	5.5 Feet	ON	ON	ON

## LED Display Panel

The LED display panel provides system feedback to the driver. Prior to installing the panel, determine if any changes to the default settings are desired (See figure 1).

## LED Display Pane DIP Switch

The default setting is switches 1-6 are 'On' and switches 7-8 are 'Off'.

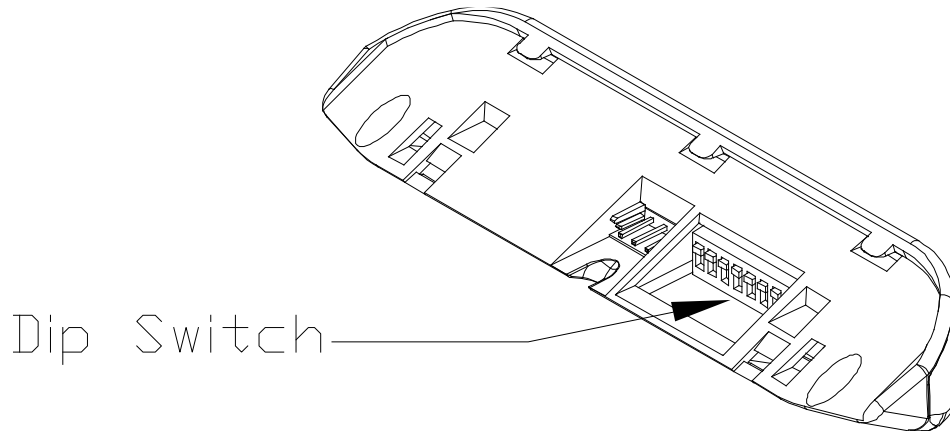

Dip Switch	Function	Note
1	Power	Must be ON
2	Data	Must be ON
3	Buzzer	ON = activate buzzer OFF = no buzzer sound
4	Buzzer Volume 1	ON = louder OFF = does not affect the loudness of buzzer volume
5	Buzzer Volume 2	ON and Dip Switch 4 ON = loudest OFF = does not affect the loudness of buzzer volume
6	Feet/Meter	ON = Feet OFF = Meter
7	LED Bar Display Swap	ON = to swap the LED bar display for LEFT/RIGHT sensor indicator when the display is installed upside down
8	Number Display Rotation	ON = to invert the displayed number when the display is installed upside down

(Figure 1)

Note: If mounting the LED panel in an inverted position, switches 7 and 8 must **both** be switched to 'On' for proper readout.

1. Using 2 of the supplied screws (different types are provided, but only 2 are needed), secure the display bracket (figure 2a or 2b), then attach the display to the bracket. If desired, drill a hole through the dash to route the display wire harness.
2. Run the display wire harness along the left (driver) side to the back of the vehicle.
3. Connect the White 3-pin connector to the proper opening on the display panel. Make sure the connector is fully seated.
4. Secure the harness along the left side of the coach.
5. Connect the Black 6-pin connector to the mating cavity on the module labeled "Output".

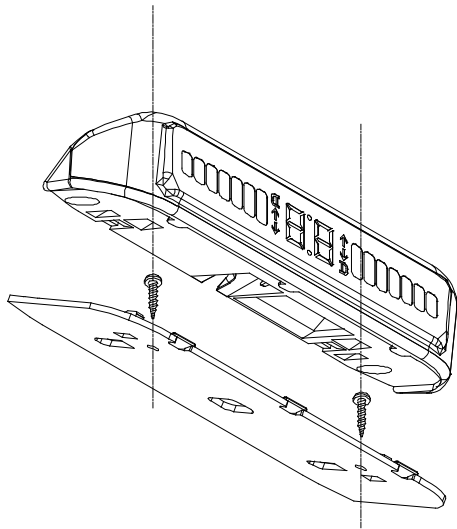

(Figure 2a - Normal Position)

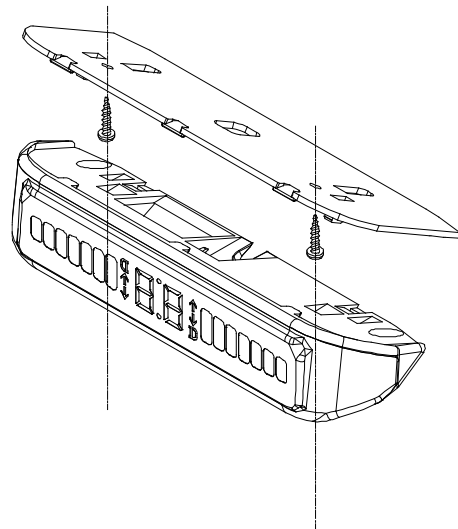

(Figure 2b - Inverted Position)

### PWR Harness

The PWR harness provides power to the Control Module when the transmission is placed in reverse.

1. Verify that chassis ignition power is Off.
2. Locate the OEM circuit that provides power to the reverse lamp in the rear tail-lamp assembly. Connect the Red wire from the HAWK4-401 PWR Harness to this circuit.
3. Connect the ground eyelet to a known good ground point near the tail-lamp assembly.
4. Connect the Black 4-pin connector to the mating cavity on the module labeled "PWR". Make sure the connector is fully seated.
- 5. The Blue and Yellow wires will not be used.**
6. Secure the harness as needed.



PWR Harness

**Note:** if using an external rear backup alarm, do not attach the HAWK4-401 Red wire to the same side tail-lamp wire as the backup alarm or it may interfere with the HAWK4-401 operation. Example: if the external backup alarm gets power from the right tail-lamp wire, the HAWK4-401 Blue wire must be attached to the left side tail-lamp wire.

# Reconnect Vehicle Battery

## Post Installation

The following checks must be made after installation of the system. If any of the checks do not pass, do not deliver the vehicle. Recheck all connections as per the installation instructions.

**Important:** Ensure no objects are present within 10 feet of the bumper while testing.

1. **Verify that the Park Brake is firmly set with the Engine Off and wheels blocked.** Turn the ignition key to "ACC" position and place the transmission in reverse. The display indicator should activate and produce a single audible beep.
2. With the aid of an assistant, verify that the sensors are connected into the proper openings on the bumper:
  - 2.1 Use a cloth to cover the two middle sensors. Holding a flat dense object (5" x 20"), approach the passenger side corner sensor from approximately 10 feet away. Verify that the LED Display shows proper distance and orientation. Repeat procedure for the driver side corner sensor.
  - 2.2 Remove covers from the middle sensors and block the corner sensors. Repeat procedure as in 2.1. Verify that the LED Display shows proper distance and orientation.
3. If the system gives a warning without an object in the proper zone (false alarm):
  - 3.1 Check for proper sensor installation and orientation (dot on sensor must be facing down).
  - 3.2 The sensors may be detecting the ground. Note: The preset of the sensitivity for the sensor height is 17 inches above the ground. To avoid false alarm, sensor height must be at least 17 inches. If sensor height is correct, adjust sensitivity (see next page).

## System Self Test

Immediately after the system powers up (when vehicle is shifted into reverse), it will do a sensor self test. If a sensor circuit is malfunctioning, or a sensor is disconnected, the corresponding sensor will be displayed briefly on the LED display. That corresponding sensor circuit should be inspected. The sensor circuits are labeled numerically at the back of the control module. On the bumper, the outermost sensor on the driver side is sensor #1, then proceeding towards the passenger side, #2, #3, and finally #4 which is the outermost sensor on the passenger side of the bumper.

### Sensor Malfunction or No-connect Visual Display Status



Sensor #1 Malfunction



Sensor #2 Malfunction



Sensor #3 Malfunction



Sensor #4 Malfunction

## Guide to Adjust System Sensitivity

1. Open the control module **left** cover using a screwdriver.
2. Use a cart or other mobile object with a piece of 3/4" plywood (18" x 24") on the side facing the sensors (figure 3). A dense material is required to reflect the ultrasonic waves.
3. Position the cart in the direct path of a sensor at the distance of 5 feet.
4. Insert a small screwdriver into the **right** potentiometer and gently turn the potentiometer clockwise to the stopping point.



(figure 3)

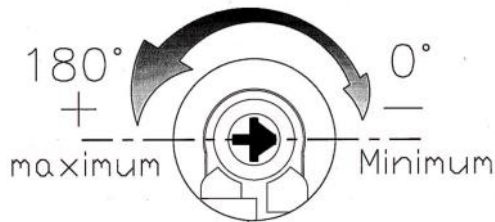
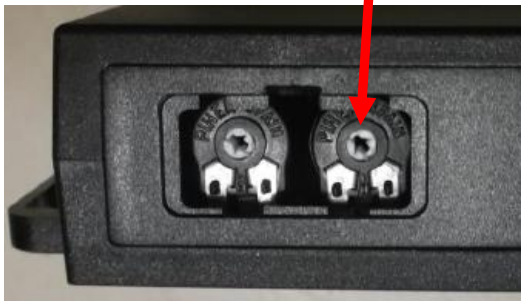

Minimum sensitivity adjustment



Maximum sensitivity adjustment

5. With the **Engine Off, set the Park Brake, block the wheels, and place the transmission in reverse.** The display panel should now have a blank reading.
6. Slowly turn the **right** potentiometer counter-clockwise until the display gives a numerical reading of the distance of the cart and has a consistent audible sound.
7. Reset the module by placing the vehicle in Park or by unplugging the module power connector. Removing the power from the module allows the module to recognize the new sensitivity adjustment.
8. Place vehicle in reverse or reinstall the module power connector. Move the cart away from the bus and note the display readings. Move the cart forward, measure the cart distance and compare the distance with the display reading.
9. Adjust the sensitivity further if needed. Turning the potentiometer clockwise reduces the sensitivity and turning the potentiometer counter-clockwise increases sensitivity. Repeat Post-Installation Testing. If necessary, readjust and retest.
10. Replace cover on the back of the control module.

## Reading the HAWK4-401 Display

- The center of the display will show the distance of detected objects.
- Each side of the display has illuminated bars, which indicate the side and distance of the detected object.
- As the detected object becomes closer, more bars will illuminate and an audible beep will alert the driver.
- The audible beeps will increase in tempo as the detected object becomes closer.
- The audible sound will become a constant noise when the detected object is in range of a collision.

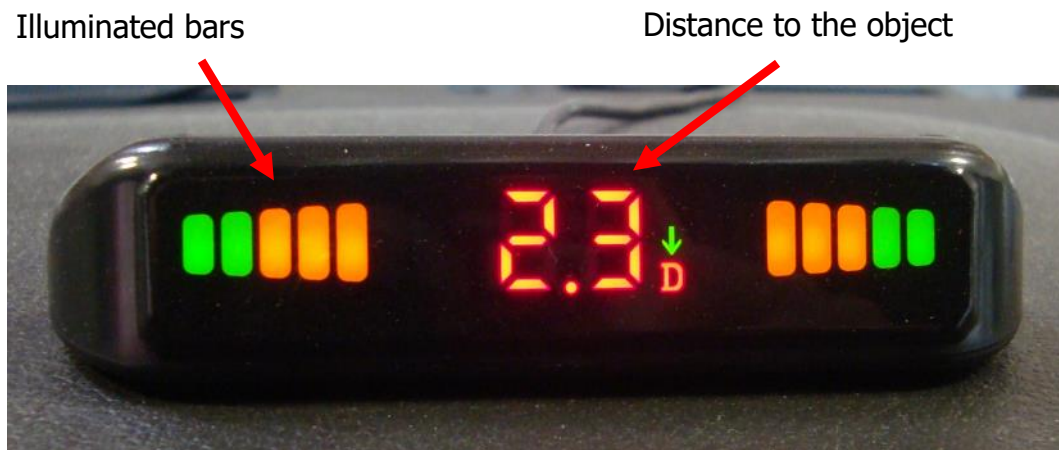

## CAUTION!

**This system is not designed to prevent contact with small or moving objects. This system is designed to provide a warning to assist the driver in detecting large stationary objects when moving in reverse at "parking speeds" of approximately 4 mph. The HAWK Reverse Assistance System may have reduced performance or be activated in inclement weather.**

**To help avoid personal injury, always use caution when in reverse and when using the HAWK Reverse Assistance System.**



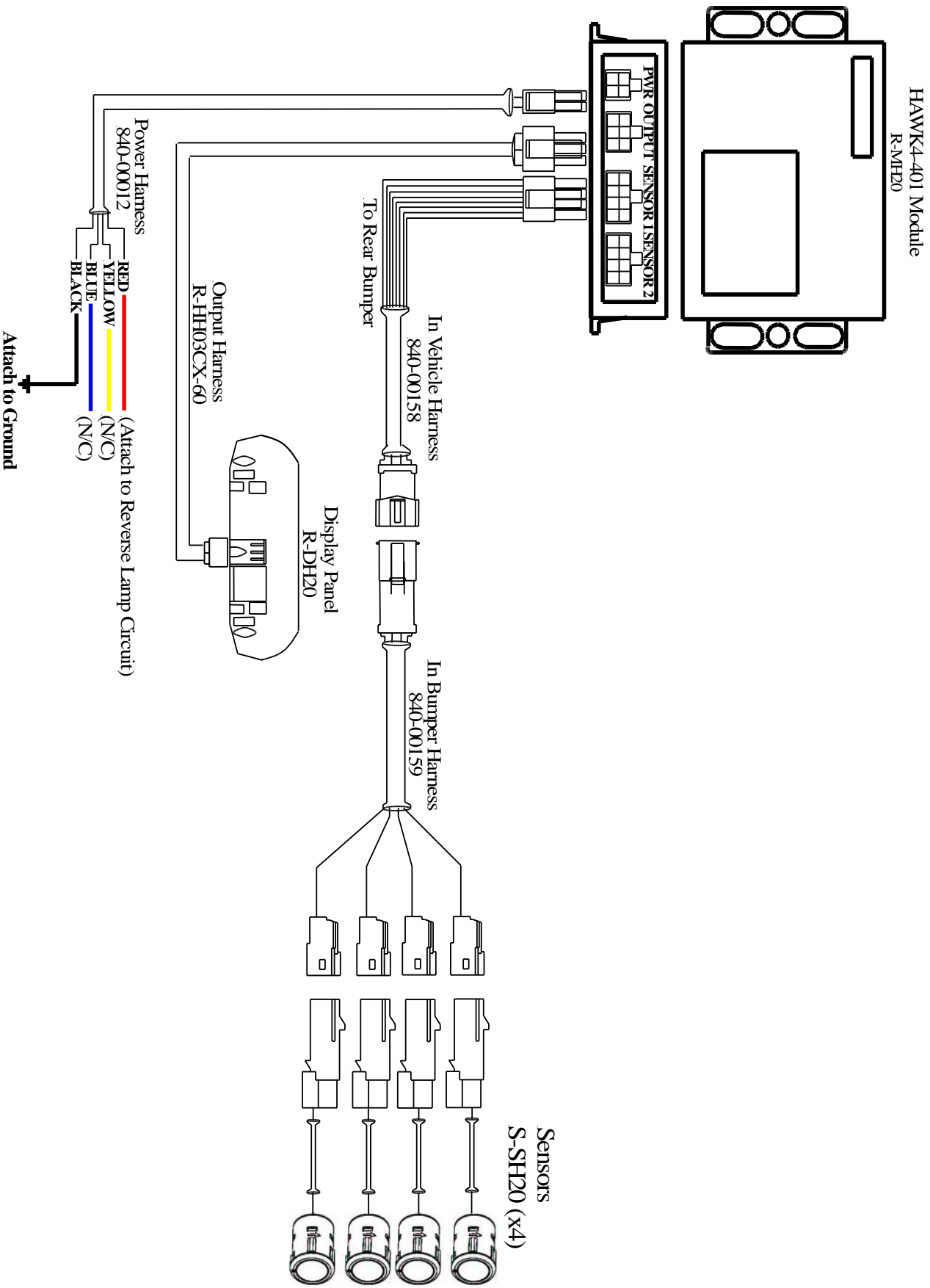

**Submit product registration at [www.intermotive.net](http://www.intermotive.net)**

If the HAWK4-401 fails any step in the Post Installation Test, review the installation instructions and check all connections. If necessary, call

HAWK4-401-012725