

H-HL519, H-HL520 Fast Idle, Lift Interlock 2026 Ford Transit



Introduction

The HighLock 519 and 520 is a wheelchair lift safety interlock which will only work with the ignition On. It will enable the lift when certain vehicle safety conditions are met, and will lock the transmission shifter in Park when the lift door is open and/or the Park Brake is applied. The HighLock also has the Fast Idle option. The Advanced Fast Idle System (AFIS) elevates engine idle speed in response to a number of triggers in order to assist electrical or mechanical systems on the vehicle.

*HL519 vs 520

- HL519 is typically used on buses with a single main passenger door, and HL520 is usually used on vans, where the Door Ajar panel will flash when *any* door is ajar.

IMPORTANT—READ BEFORE INSTALLATION

It is the installer's responsibility to route and secure all wiring harnesses where they cannot be damaged by sharp objects, mechanical moving parts and high heat sources. Failure to do so could result in damage to the system or vehicle and create possible safety concerns for the operator and passengers.

Avoid placing the module where it could encounter strong magnetic fields from high current cabling connected to motors, solenoids, etc. Avoid radio frequency energy from antennas or inverters next to the module. Avoid high voltage spikes in vehicle wiring by always using diode clamped relays when installing upfitter circuits.

Installation Instructions

Disconnect vehicle battery before proceeding with installation



WARNING
Disconnect the battery to
prevent setting a check engine
light.

CAUTION

All electronic products are susceptible to damage from Electrostatic Discharge or ESD. Ground yourself before handling or working with the module and harnessing by first touching chassis ground, such as the barrel of the cigarette lighter.



H-HL519/520 Module

Remove the lower dash panel below the steering column area and find a suitable location to mount the H-HL519/520 module. Locate the module in an area away from any external heat sources (engine heat, heater ducts, etc.). Do not mount the module until all wire harnesses are routed and secure. The last step of installation is to mount the module.

Gateway Plug and Play Harness (6-pin connector)

1. Locate the vehicles Gateway Module. It will be mounted behind the glove compartment.
2. Press the tabs inward on the sides of the glove compartment and fully lower it.
3. Remove the 3 nuts securing the Gateway module to the vehicle.
4. Remove the 26-pin connector from the side of the Gateway module and plug into the mating connector on the H-HL519/520 harness.
5. Plug the male 26-pin connector from the H-HL519/520 harness into the Gateway module.
6. Reinstall the Gateway module and the glove compartment.
7. Plug the free end of the Data Link harness into the mating 6-pin connector on the H-HL519/520 module.

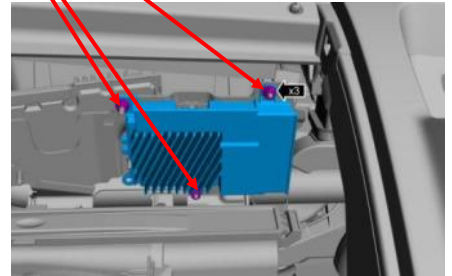
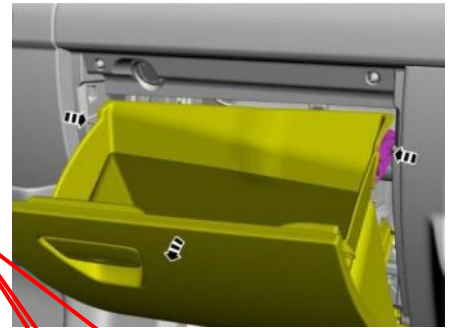

Shift Lock Connection

There are multiple cup holder options for the Ford Transit. Please follow the appropriate instructions.

Option 1

- Remove the cup holder.



Shift Lock Connection (continued)

- Locate connector 2810 (12-pin connector). Remove the OEM connector and plug it into the mating 12-pin connector T-harness supplied with the H-HL519/520. Plug the remaining male connector into the OEM cavity.



Option 2

- Remove the under dash panel by firmly grasping it and pulling it towards the rear of the vehicle.



Shift Lock Connection (continued)

- Remove the two screws as seen in the photo.

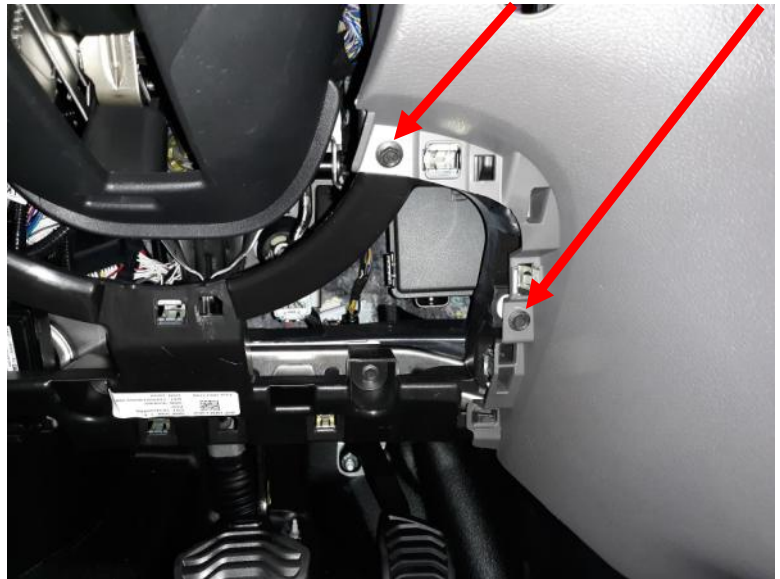

- Remove the trim panel on the passengers side (see photo) by using a plastic trim removal tool.



Shift Lock Connection (continued)

- Open the glove box and remove the screw as shown in the photo.



- Remove the gear shifter trim panel using a plastic trim removal tool.



Shift Lock Connection (continued)

- Remove the small trim piece shown in photo.



- Remove the center under dash panel by firmly grasping it and pulling it towards the rear of the vehicle.



Shift Lock Connection (continued)

- Locate connector 2810 (12-pin connector). Remove the OEM connector and plug it into the mating 12-pin connector T-harness supplied with the H-HL519/520. Plug the remaining male connector into the OEM cavity.



Fast Idle SEIC Installation

1. Locate the SEIC wire bundle in the engine bay. See pictures

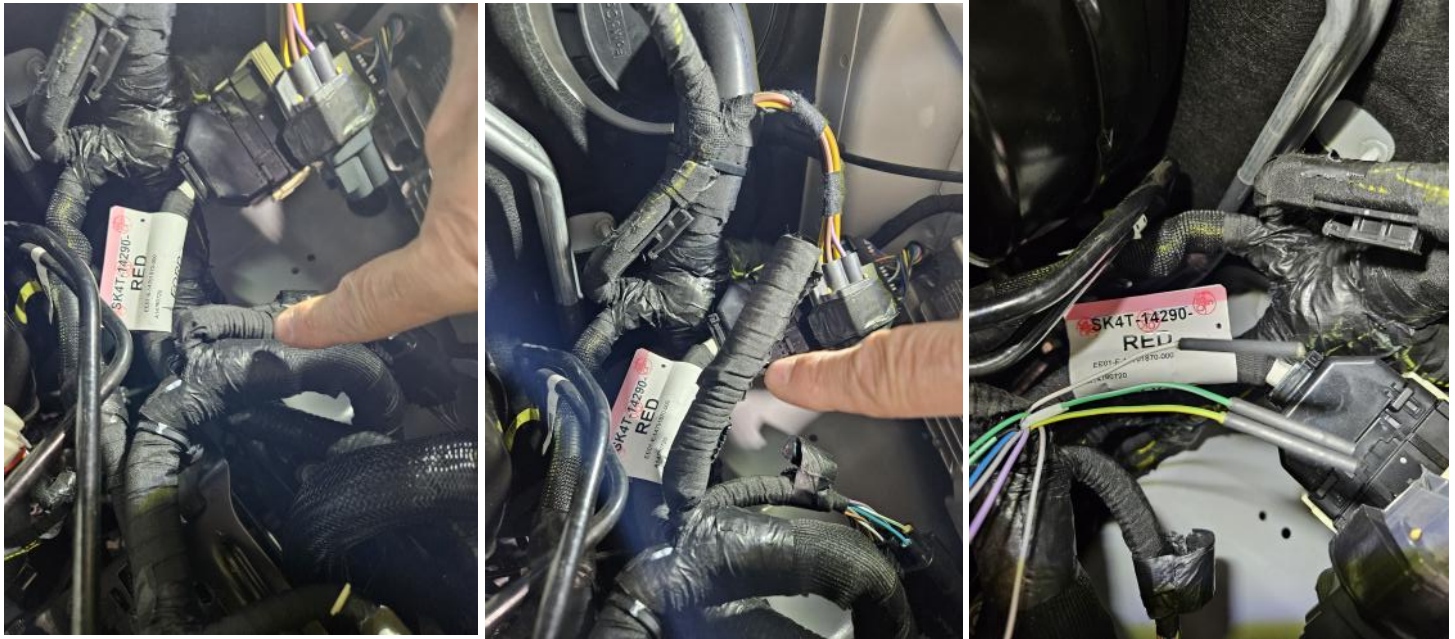

SEIC Installation (InterMotive Harness 840-00420-15)

1. Expose the YEL/GRN, GRN/WHT, and WHT/BRN wires
2. Using solder and heatshrink, solder the following wires together:
3. GRN/VLT wire from InterMotive SEIC Harness to the WHT/BRN OEM wire
4. YLW/GRN wire from the InterMotive SEIC Harness to the YLW/GRN OEM wire
5. GRN wire from the InterMotive SEIC Harness to the GRN/WHT OEM wire.
6. Plug the YLW/GRN wire with the crimped terminal from the InterMotive SEIC Harness into Pin #9 of the 12 way connector on Harness **840-00046**

Fast Idle Triggers

Trigger Name	Trigger Conditions	Disable Conditions
Manual Engage Input	Fast Idle Engage Input wire activated	Fast Idle Engage Input wires not active
VBAT Low (if enabled)	VBAT < 12.5V (default)	VBAT > 13.5V for > 5 minutes (default)
Parking Brake (if enabled)	Parking Brake applied	Parking Brake Released

Fast Idle Preconditions

The following preconditions must be met prior to initiating Fast Idle operation:

- Vehicle speed zero
- Transmission in Park
- Accelerator pedal not applied
- Engine Coolant temperature less than 230°F
- Engine RPM must be greater than 200 and less than 2800
- Service Brake not applied
- Parking Brake must be applied if this feature is enabled

LED Dash Display Panel

1. Locate a suitable position on the dashboard within view of the driver for mounting the LED Display Panel. The length of the display harness is 40". This is the maximum distance the display can be mounted from the H-HL519/520 module. Drill a 5/8" hole in the dashboard where the center of the display will be located, being careful not to damage anything behind the dashboard.
2. Attach the 4 Pin LED display harness to the H-HL519/520 Module's 4-pin connector. Run the free end of the display harness under the dash and out through the 5/8" hole.
3. Attach the end of the display harness to the LED Display Panel.
4. Ensure panel is level and secure using the supplied screws.



Control Inputs, Output and Lift Inhibit Connections

12-pin I/O connector

The H-HL519/520 provides three ground side inputs and one ground side output.

Lift Inhibit pin-2: Grounding this input will prevent the module from supplying power on its Wheel Chair Lift Output pin.

Door Ajar pin-5: (Optional input) Insert the green wire (provided with panel) into the connector and lengthen as needed, using solder, heat shrink and tape. Connect to the door switch so that a ground is supplied when the door is open.

Fast Idle SEIC - Pin-9: This output is used to activate Fast Idle when any of the triggers are engaged.

Fast Idle- Engage pin-10: This input pin can be connected to a ground side switch to activate Fast Idle.

A 12-pin mating connector is provided along with 5 terminals (two extra). To use any of these inputs/output, properly crimp a connector terminal provided to the installer supplied wire using the correct crimping tool (Molex Part# 11-01-0197), and insert into the correct connector pin housing.

Ensure the terminals are fully seated in the connector. The largest wire that can be used with these terminals is 16 AWG. Snap this connector into the H-HL519/520 module's 12-pin connector.

12-pin connector pin out definition

- Pin #1 - Yellow - Shift Lock output
- Pin #2 - Inhibit input - (GND) to Inhibit Lift
- Pin #3 - Not Used
- Pin #4 - Not Used
- Pin #5 - Green Wire (Door Ajar Input) Optional
- Pin #6 - Not Used
- Pin #7 - Red - Not Used
- Pin #8 - Not Used
- Pin #9 - Fast Idle SEIC Output
- Pin #10 - Fast Idle Engage - Optional ground input to engage Fast Idle
- Pin #11 - Not Used
- Pin #12 - Red - Not Used

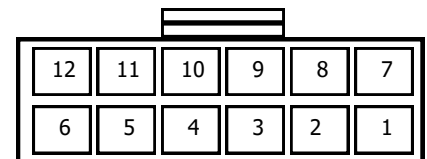

Back of Connector



Mating 12 pin I/O Connector provided

Control Inputs, Output and Lift Inhibit Connections (continued)

Lift Connector 4-pin

The H-HL519/520 module provides a 4-pin connector to enable wheelchair lift operation. The pins are defined as follows:

- Pin #1 - Not Used
- Pin #2 - Lift power/Vehicle Secure output (Orange wire), connect to Wheel Chair Lift to enable operation.
- Pin #3 - Lift door input (Gray wire), connect to Lift Door switch, grounded when door open.
- Pin #4 - Lift power input (Yellow wire), connect this to a 12V fused ignition source, hot in run and crank.

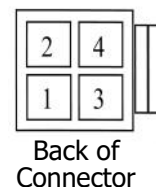

HL519/520 Module Mounting

Ensure all harnesses are properly connected and routed, and are not hanging below the dash area. Mount the H-HL519/520 module using screws or double sided tape and reinstall all removed panels.

Reconnect vehicle battery

Lift Door Identification

The module comes from the factory with the discrete lift door input identified as the lift door. If the side door or rear door happens to be the lift door, the module needs to know which of the two possible doors (side or rear) is defined to be the lift door; perform the following procedure to accomplish this:

1. Assure Side and Rear Doors are closed.
2. Vehicle is in PARK with Key in the RUN position and engine OFF.
3. Park Brake is applied.
4. Put the module in diagnostic page 4 by momentarily pressing the Red “test” button, **FOUR** times- verify the status LED is flashing code 4-4.
5. Pump the Service Brake pedal (4 times within 5 sec) until you see module LEDs 8-10 stay on solid. You will have one minute to choose which door will be used for the lift.
6. Open the chosen lift door. LED 8-10 will turn off and the LED associated with the lift door will turn on. See table below.
7. Verify the lift door is “known” by opening and closing it while watching the “Lift Door Open” LED on the display panel.



Status LED	4-4
LED5	Discrete Input
LED6	Slide Door
LED7	Rear Door

Post Installation Testing

The following checks must be made after installation of the system, to ensure correct and safe operation of the lift. If any of the checks do not pass, do not deliver the vehicle. Recheck all connections as per the installation instructions.

Lift Interlock System Testing

Begin the checklist with the vehicle in the following state:

- Lift stowed
- Lift Door closed
- Park Brake set (PB)
- Transmission in Park (P)
- Ignition off (Key off). Wait until the module goes into "Sleep" mode (all panel LEDs OFF) which takes approximately 5 minutes

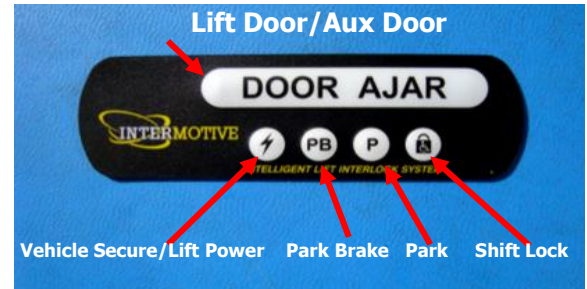

1. Turn ignition key On (to "Run"), verify the module wakes up and all 5 LEDs illuminate for approximately 2 seconds. The lower icon LEDs are backlit and should remain illuminated whenever the module is awake.
2. Verify that the Park LED, the Park Brake LED, and the Shift Lock LED remain illuminated.
3. Attempt to deploy the lift. Verify the lift does not deploy with the Lift Door closed.
4. With key on, Lift Door open, Park Brake set and transmission in Park, all 5 LEDs will be illuminated. Attempt to deploy the lift. Verify the lift deploys. Stow the lift.
5. With key on, Lift Door open, transmission in Park, release Park Brake. Verify that the Park Brake (PB) and Vehicle Secure LEDs go out. Attempt to deploy the lift. Verify the lift does not deploy.
6. With key on, Lift Door closed, Park Brake set, attempt to shift the transmission out of Park. Verify the transmission will not shift out of Park.
7. With key on, Lift Door open, Park Brake released, attempt to shift the transmission out of Park. Verify the transmission will not shift out of Park.
8. With key on, Lift Door closed, Park Brake released and the Service Brake applied, verify the transmission lever will shift out of Park.
9. If equipped with a connection for an additional door (Aux Door) the Door Ajar LED will blink on the display panel until the door is closed. The H-HL520 will flash the Door Ajar LED when any of the doors are opened. If the **Lift Door** is open, the Door Ajar LED will stay on steady, taking priority over the additional door input.

Note: All LEDs are active and there is no display backlighting.

Post Installation (continued)

Fast Idle

The Fast Idle option has several "auto triggers" that will increase engine RPM. These include low battery voltage, air conditioner on, engine cold, and external switch input on pin #10 of the 12 Pin connector (I/O 4).

1. Press the Service Brake for 1 second. Fast idle will temporarily disengage anytime the brake pedal is pushed, but will automatically reengage after approximately 2 seconds once the Service Brake pedal is released.
2. Shut down the engine and verify that all LED's turn off, which may take a few minutes. Do not activate any vehicle controls during this time (windows, mirrors, doors, etc.).

**Leave in Vehicle
Operating Instructions H-HL519/520
Fast Idle, Lift Interlock
2026 Ford Transit**



Advanced Fast Idle Operation

The Advanced Fast-Idle System (AFIS) option of the H-HL519/520 includes Charge-Protect and Manual engage modes. Charge-Protect is a feature that maintains vehicle charging system voltage by increasing and controlling vehicle idle speed when necessary. Whenever the charging system voltage falls below a minimum voltage of 12.5V, the AFIS feature will increase idle speed and maintain fast idle until one of the safety conditions is no longer met, the user cycles the shift lever, or the user manually disengages fast idle. The Charge-Protect and Manual engage modes also require that all safety conditions are met.

Safety conditions that must be met to engage or maintain Fast Idle operation

Vehicle NOT moving (speed = 0 MPH).

Service Brake NOT pressed.

Vehicle Transmission Range in Park

RPM inside of safe operating range.

Transmission Fluid Temperature below 250° F.

Engine Coolant Temperature below 230° F.

Fast Idle may be initiated by either a manual or automatic Fast Idle trigger. The AFIS strategy can only command elevated idle when certain safety conditions are met (see above section). Fast Idle operation can be terminated by a safety condition violation. If a Fast Idle operation terminates due to a safety condition violation, automatic Fast Idle is unavailable until Park is de-asserted and re-asserted. Shift out of Park and back into Park. The Fast Idle RPM is 1500 RPM.

Manual Fast Idle Start Trigger

Fast Idle Input – ground applied to 12 Pin connector Pin #10 of the H-HL519/520 Module, such as an input from Coach AC.

Automatic Fast Idle Start Trigger

Charge Protection - Battery voltage less than 12.5V.

Fast Idle Disengagement Triggers

Safety Condition Violation.

Engine Coolant Temperature > 230° F.

Open or battery voltage on 12 Pin connector Pin #10 while in Fast Idle caused by 12 Pin connector Pin #10 fast idle input.

Transmission Fluid Temperature above 250° F.

Note: Fast Idle will temporarily stop anytime the brake pedal is depressed, but will automatically reengage after approximately 2 seconds once the brake pedal is released.

When additional electrical or A/C loads are in use, engine RPM may drop. The AFIS feature will raise the RPM back up to the fast idle speed. When the load is removed, engine RPM will increase. AFIS will lower the RPM back to the fast idle speed.

Operating Instructions (continued)

Lift Operation

The Intelligent Lift Interlock System of the HL519/520 is a microprocessor driven system for controlling wheelchair lift operation. Lift operation will only be allowed when all of the following conditions are met:

- The vehicle is in “Park”.
- The parking brake is applied.
- The vehicle ignition is on.
- The lift door is open.
- Lift inhibit is not activated.

The HL519/520 will not allow the vehicle to be shifted out of park if the lift door is open. As an added feature, it also will not allow the vehicle to be shifted out of park when the parking brake is applied. This feature eliminates excessive parking brake wear due to driving with the parking brake applied.

If the vehicle has Daytime Running Lights, they will be

activated when the Lift Door is Open and/or the Park Brake is On and the Ignition key is On.

When the vehicle is first started, or if the key is turned to the “Run” position, the five LED’s, on the display panel will illuminate for 2 seconds as a prove out of the LED’s. The module will stay awake for several minutes after the ignition is turned off.

The **HL520** will flash the Door Ajar LED when any of the doors are opened.

After prove out, the operation of the LED panel is as follows:

Vehicle Secure – Illuminates in green if the lift is enabled. This means that all conditions for lift operation have been met and the lift has been supplied a vehicle secure signal.

Park Brake – Illuminates in Red when the parking brake is applied.

Park - Illuminates in Red when the vehicle transmission is in the park range.

Lift Door - Illuminates in Red when the lift door is open.

Shift Lock - Illuminates in Red when the lift door is open and/or the parking brake is applied. If illuminated, the driver will not be allowed to shift out of park.

Confirmation Signal – The vehicle lamps and radio will cycle briefly when the ignition is on and the lift door is initially closed. This is a confirmation signal sent from the Ford Econoline controller.

All Five Interlock LED’s must be illuminated for the Wheelchair Lift to operate

The H-HL519/520 initializes when the vehicle ignition is On. After the initialization, the H-HL519/520 requests various vehicle data by sending data request messages across the OEM CAN diagnostic data network and all control logic is performed. When the HL519/520 module has been running and the vehicle ignition is turned to the Off or accessory positions, the module goes into a low current consumption “sleep” mode. This may take up to 5 minutes.

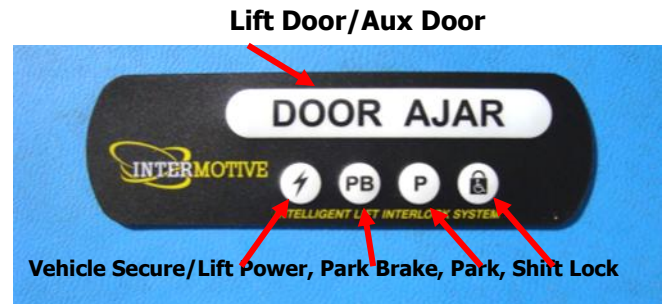

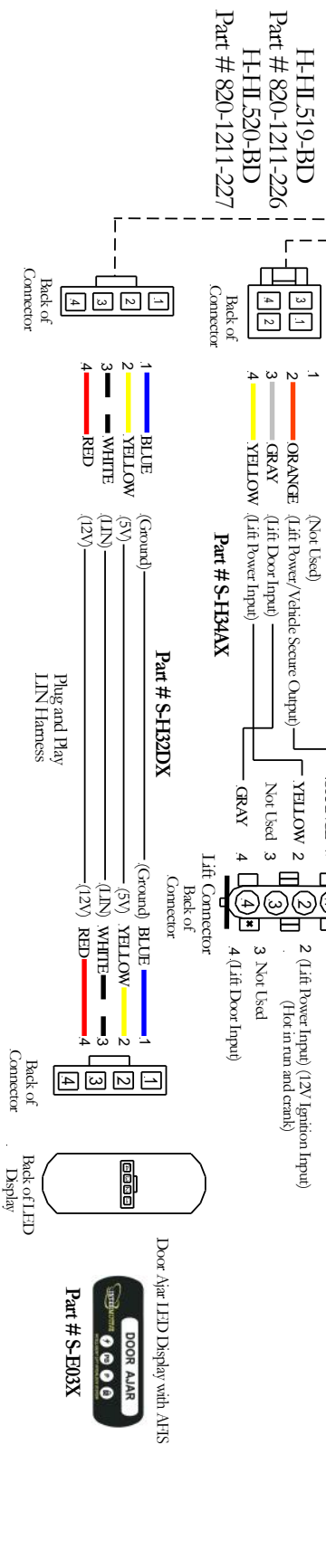
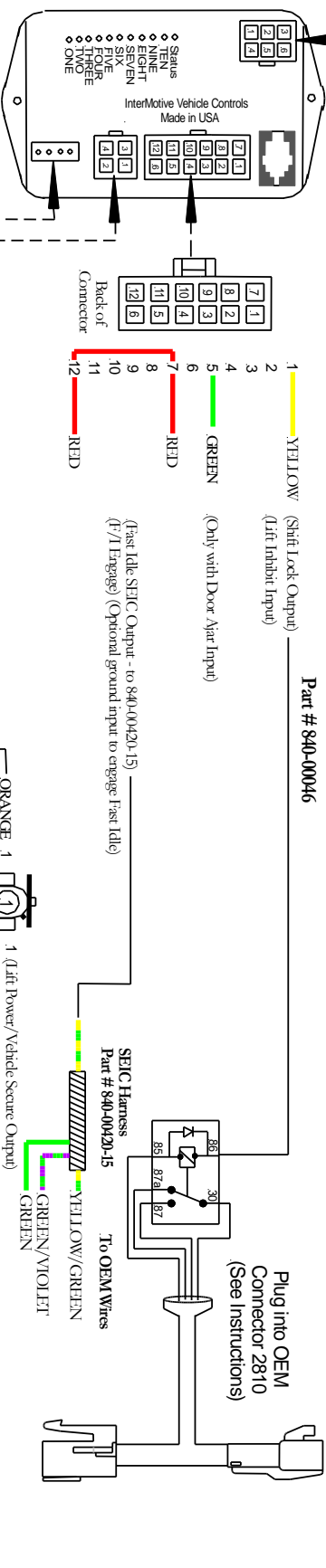
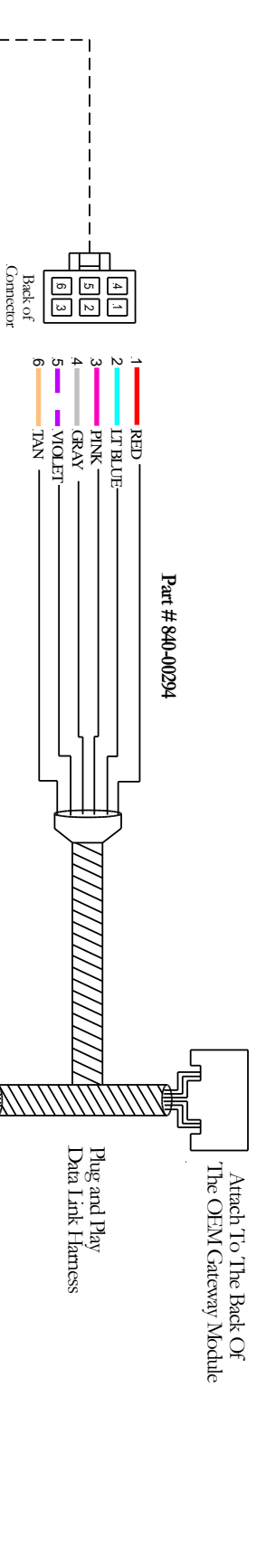

Submit product registration at www.intermotive.net

If the HL519/520 fails any step in the Post Installation Test, review the installation instructions and check all connections. If necessary, call InterMotive Technical Support at (530) 823-1048.