

Instructions



GTWY519, GTWY520* Fast Idle, Shift Interlock, I/O 2020 - 2024 Ford Transit (B-) 2022 - 2023 Ford Transit w/ Sync 4 (G-)

Introduction

The Gateway 519 and 520 are wheelchair lift safety interlocks which allows lift operations with the ignition key On. They will enable the lift when certain vehicle safety conditions are met, and will lock the transmission shifter in Park when the lift door is open and/or the Park Brake is applied. The Gateway module also provides an engine Fast Idle function. This Advanced Fast Idle System (AFIS) elevates engine idle speed in response to a number of triggers in order to provide battery charge protect and A/C boost on the vehicle.

Gateway 519/520 Add-On Options

In addition to interlock and Fast Idle features, Intermotive offers the following option:

- Gateway with Door Ajar: Monitors an additional door other than lift door.

*Gateway 519 vs 520

- GTWY519 is typically used on buses with a single main passenger door, and GTWY520 is usually used on vans, where the Door Ajar panel will flash when *any* door is ajar. The Gateway 519 is also capable of doing this by performing the procedure described in the instructions (page 11).

IMPORTANT—READ BEFORE INSTALLATION

It is the installer's responsibility to route and secure all wiring harnesses where they cannot be damaged by sharp objects, mechanical moving parts and high heat sources. Failure to do so could result in damage to the system or vehicle and create possible safety concerns for the operator and passengers. Avoid placing the module where it could encounter strong magnetic fields from high current cabling connected to motors, solenoids, etc. Avoid radio frequency energy from antennas or inverters next to the module. Avoid high voltage spikes in vehicle wiring by always using diode clamped relays when installing upfitter circuits.

Installation Instructions

Disconnect vehicle battery before proceeding with installation.



WARNING
Disconnect the battery to prevent setting a check engine light.

CAUTION

All electronic products are susceptible to damage from Electrostatic Discharge or ESD. Ground yourself before handling or working with the module and harnessing by first touching chassis ground, such as the barrel of the cigarette lighter.



Instructions

Installing the Gateway Module

Remove the lower dash panel below the steering column and find a suitable location to mount the module. Do not mount the module until all wire harnesses are routed and secure. The last step of the installation is to mount the module. Mount the module in an area away from any external heat sources (engine heat, heater ducts, etc.), route the harnesses such that the tilt steering column does not contact them in the full down position. When installing the harnesses, leave several inches of take-out in order to remove the module if necessary.

Gateway Plug and Play Harness (B- 6-pin connector)

1. Locate the vehicles Gateway Module. It will be mounted below the lower left dash panel.
2. Remove the harness behind the Gateway module by pressing the locking tab and pulling outward.
3. Plug the Female side of the InterMotive Gateway Harness into the back of the Gateway module. Ensure the connection is fully seated and secured by the locking tab.
4. Plug the Male side of the InterMotive Data Link Harness into the Gateway harness.
5. Secure the GTWY519/520 harness so that it does not hang below the lower dash panel.
6. Plug the free end of the Data Link harness into the mating 6-pin connector on the GTWY519/520 module.

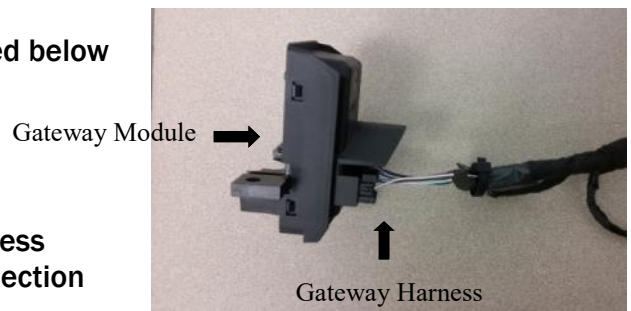

Gateway Plug and Play Harness (G- 26 Pin connector)

1. Locate the vehicles Gateway Module. It will be mounted behind the glove compartment.
2. Press the tabs inward on the sides of the glove compartment and fully lower it.
3. Remove the 3 nuts securing the Gateway module to the vehicle.
4. Remove the 26-pin connector from the side of the Gateway module and plug into the mating connector on the G-GTWY519/520 harness.
5. Plug the male 26-pin connector from the G-GTWY519/520 harness into the Gateway module.
6. Reinstall the Gateway module and the glove compartment.
7. Plug the free end of the Data Link harness into the mating 6-pin connector on the G-GTWY519/520 module.

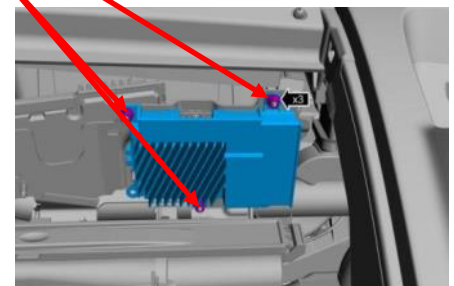

Instructions

Shift Lock Connection

There are multiple cup holder options for the Ford Transit. Please follow the appropriate instructions.

Option 1

- Remove the cup holder.



Shift Lock Connection (continued)

- Locate connector 2810 (12-pin connector). Remove the OEM connector and plug it into the mating 12-pin connector T-harness supplied with the GTWY519/520. Plug the remaining male connector into the OEM cavity.



Instructions

Option 2

- Remove the under dash panel by firmly grasping it and pulling it towards the rear of the vehicle.



- Remove the two screws as seen in the photo.

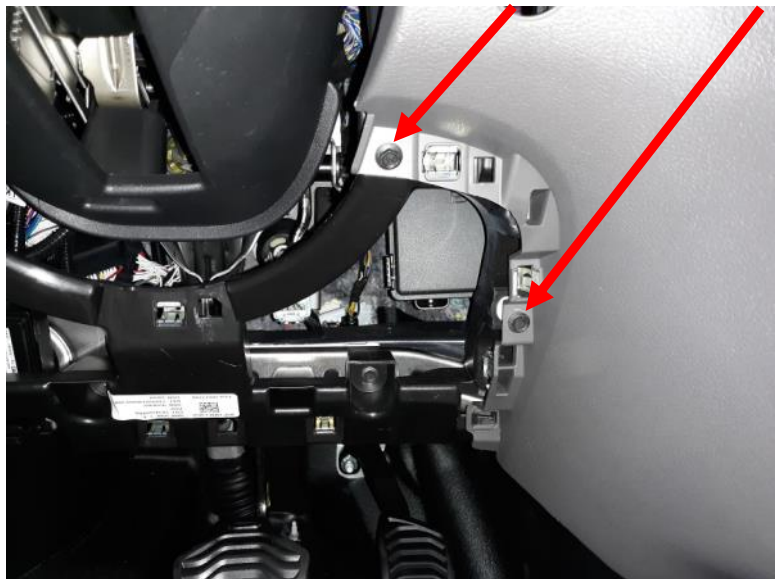

Instructions

Shift Lock Connection (continued)

- Remove the trim panel on the passengers side (see photo) by using a plastic trim removal tool.



- Open the glove box and remove the screw as shown in the photo.



Instructions

Shift Lock Connection (continued)

- Remove the gear shifter trim panel using a plastic trim removal tool.



- Remove the small trim piece shown in photo.



Instructions

Shift Lock Connection (continued)

- Remove the center under dash panel by firmly grasping it and pulling it towards the rear of the vehicle.



- Locate connector 2810 (12-pin connector). Remove the OEM connector and plug it into the mating 12-pin connector T-harness supplied with the GTWY519/520. Plug the remaining male connector into the OEM cavity.



Instructions

LED Dash Display Panel

1. Locate a suitable position on the dashboard within view of the driver for mounting the LED Display Panel. The length of the display harness is 40". This is the maximum distance the display can be mounted from the GTWY519/520 module. Drill a 5/8" hole in the dashboard where the center of the display will be located, being careful not to damage anything behind the dashboard.
2. Attach the 4 Pin LED display harness to the GTWY519/520 Module's 4-pin connector. Run the free end of the display harness under the dash and out through the 5/8" hole.
3. Attach the end of the display harness to the LED Display Panel.
4. Ensure panel is level and secure using the supplied screws.



Instructions

Control Outputs, Input, and Lift Inhibit Connections - 12-pin I/O connector (optional)

The GTWY519/520 provides three ground side configurable outputs and one configurable input/output. The outputs can provide vehicle information such as Vehicle Speed, Park, Park Brake, etc., and are configured per customer requirements at InterMotive prior to shipping. These outputs can be used to control upfitter circuits and can sink up to 1/2 amp. The input pin can be connected to a ground side switch to activate Fast Idle or Shift Lock. Grounding the Lift Inhibit pin-2 input will prevent GTWY519/520 from supplying power on its Wheel Chair Lift Output pin (see below).

A 12 pin mating connector and seven terminals (two extra) are provided. To use any of these outputs, properly crimp a connector terminal provided to the installer supplied wire using the correct crimping tool (Molex Part# 11-01-0197), and insert into the correct connector pin housing. Ensure the terminals are fully seated in the connector. The largest wire that can be used with these terminals is 16 AWG. Snap this connector into the GTWY519/520 module's 12-pin connector.

Shift Lock Control Input - Grounding pin #11 on the 12 pin connector will lock the transmission shifter, if the vehicle is in Park. This can be used to prevent the vehicle from driving when equipment has not been properly stowed or an emergency door is open, etc. This can be connected to any number of grounding switches (connected in parallel) which can effectively "lock the vehicle down."

12-pin Input Output connector pin out definition

- Pin #1 - Yellow - Shift Lock output
- Pin #2 - Inhibit input - ground to Inhibit Lift
- Pin #3 - I/O 2 - Configured output
- Pin #4 - I/O 3 - Configured output
- Pin #5 - Green - Door Ajar Input - Ground Signal (Only with Door Ajar Panel Option)
- Pin #6 - Not Used
- Pin #7 - Red - Not Used
- Pin #8 - Not Used
- Pin #9 - I/O 1 - Configured output
- Pin #10 - I/O 4 - Configured I/O Pin
- Pin #11 - Dedicated Shift Lock input - ground to activate Shift Lock
- Pin #12 - Red - Not Used



12 Pin IO
Connector

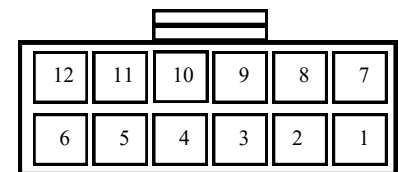

Back of Connector

Lift Connector 4-pin

The GTWY519/520 module provides a 4-pin connector to enable wheelchair lift operation. The pins are defined as follows:

- Pin #1 - RPM Adjust
- Pin #2 - Lift power/Vehicle Secure output (Orange wire), connect to Wheel Chair Lift to enable operation.
- Pin #3 - Lift door input (Gray wire), connect to Lift Door switch, grounded when door open.
- Pin #4 - Lift power input (Yellow wire), connect this to a 12V fused ignition source, hot in run and crank.

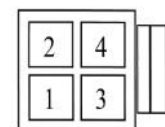

Back of
Connector

Instructions

GTWY 519 Additional Options Installation

GTWY 519-D - Door Ajar Display Panel - a green wire is included with the panel. Insert one end of the green wire into Pin #5 of the GTWY519/520 12-pin connector. Attach the other end of the green wire to the door switch wire that provides a ground when the chosen door is open.

GTWY519/520 Mounting Location

Ensure all the harnesses are properly connected and routed, and are not hanging below the dash area. Mount the module as described on page one and secure using two screws or double sided tape.

Reconnect the vehicle battery

Lift Door Identification

The module comes from the factory defaulted to use the discrete lift door input (cutaway bus applications). If the OEM slider or rear door is being used as the lift door, the module can read the OEM door switches over the network (and will not use the discrete wire), but needs to know which of the two possible doors (slider or rear) is the lift door. Perform the following procedure to let the GTWY module know which door is being used:

1. Assure Slider and Rear Doors are fully closed.
2. Place the vehicle in PARK with Key in the RUN position and engine OFF.
3. Park Brake must be set (On).
4. The GTWY module must be put in Diagnostic Mode by momentarily pressing the Red "Test" button (see picture). The amber status LED on the module will start flashing. Press the Red "Test" button repeatedly until the amber status LED is flashing **FOUR** times (4 flashes, pause, 4 flashes, etc.).
5. Tap the Service Brake pedal repeatedly until you see module LEDs 8-10 come on solid (it will take 4 taps within 5 sec). You will now have one minute to choose which door is being used for the lift.
6. Open the lift door; LED 8-10 will turn off and the LED associated with the Lift door will turn on.
7. Shut the key off, then back on to exit Diagnostic Mode. The LEDs on the module will shut off.
8. Confirm the correct lift door has been selected by cycling the lift door and observing the **door open/Door Ajar** LED on the dash panel.

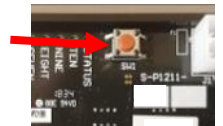

Amber Status LED	4 flashes
LED5	Discrete wire Input
LED6	Slider Door
LED7	Rear Door

Instructions

Post Installation / Check List

The following checks must be made after installation of the system, to ensure correct and safe operation of the lift. If any of the checks do not pass, do not deliver the vehicle. Recheck all connections as per the installation instructions.

Begin the checklist with the vehicle in the following state:

- Lift stowed
- Lift Door Closed
- Park Brake set (PB)
- Transmission in Park (P)
- Ignition off (Key off). Wait until the module goes into "Sleep" mode which takes approximately 40 seconds.

Lift Door/Aux Door



Vehicle Secure/Lift Power Park Brake Park Shift Lock

1. Turn ignition key on (to "Run"), verify the module wakes up and all 5 LEDs illuminate for approximately 2 seconds then turn off. The lower icon LEDs are backlit and will remain illuminated whenever the module is awake.
2. Verify that the Park LED, the Park Brake LED, and the Shift Lock LED remain illuminated.
3. Attempt to deploy the Lift. The Lift must not deploy with the Lift Door closed.
4. With key on, Lift Door open, Park Brake set and transmission in Park, all 5 LEDs will be illuminated. Attempt to deploy the Lift. The Lift should deploy. Stow the lift. **Note:** If the Lift does not operate, check the GTWY 519 LIFT connector. Pin 4 should have 12V (Lift power input), and pin 2 should have 12V (Lift Power/Vehicle Secure output).
5. With key on, Lift Door open, transmission in Park, release Park Brake. Verify that the Park Brake (PB) LED goes out .
6. Attempt to deploy the Lift. Verify the Lift does not deploy.
7. With key on, Lift Door closed, Park Brake set, attempt to shift transmission out of Park. Verify transmission will not shift out of Park.
8. With key on, Lift Door open, Park Brake released, attempt to shift transmission out of Park. Verify transmission will not shift out of Park.
9. With key on, Lift Door closed, Park Brake released and the Service Brake applied, attempt to shift transmission out of Park. The transmission shift lever will now shift out of Park.
10. When an additional door (Aux Door) is open, the Door Ajar LED will blink on the display panel until the door is closed.

The Gateway 520 will flash the Door Ajar LED when any of the doors are opened.

If the Lift Door is open, the Door Ajar LED will stay on steady, taking priority over the additional door input(s).

Instructions

Door Ajar LED Panel (continued)

If the user would like the Door Ajar LED to flash when any of the doors are open with the Gateway 519, perform the following procedure:

1. Place the key in Run with the engine OFF.
2. Jump a momentary ground onto the Test pad on the module until LED's light.
3. Apply the Parking Brake and place the vehicle in Neutral.
4. Rapidly depress and release the Service Brake 5 times in 5 seconds.
5. All LED's will flash when successful.
6. Cycle the key for the procedure to take effect.

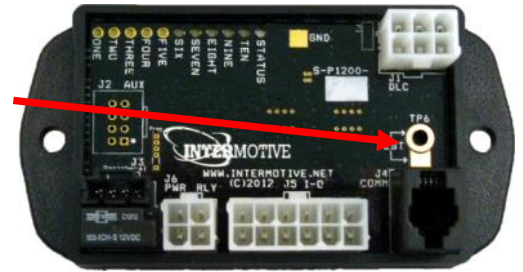

Fast Idle

The Fast Idle option has several “auto triggers” that will increase engine RPM. These include low battery voltage, air conditioner On, engine cold, and external switch input on pin #10 of the 12 Pin connector (I/O 4).

1. Press the Service Brake for 1 second. Fast idle will temporarily disengage anytime the brake pedal is pushed, but will automatically re-engage after approximately 2 seconds once the Service Brake pedal is released.
2. Exit Fast Idle mode by pressing the Service Brake and the Yellow Manual ENGAGE button together. Fast Idle will cancel and the Green LED will turn off. This will disable Fast Idle until the key or transmission range is cycled.
3. Shut down the engine and verify that all LED's turn off, which may take a few minutes. Do not activate any vehicle controls during this time (windows, mirrors, doors, etc.).

DO NOT PUT VEHICLE IN SERVICE IF IT DOES NOT PASS ALL OF THE ABOVE TESTS
Contact InterMotive at 530-823-1048 for technical assistance.

Instructions

Setting Fast Idle RPM Speeds (900 RPM - 2000 RPM)

The GTWY519/520 has two separate configurable RPM settings (heater boost and the default setting). The heater boost is triggered on engine start-up and aids in warming up the engine quickly. The default setting is triggered by low battery voltage, air conditioner On, or external switch inputs. The two settings are changed by doing the following procedure:

- **Heater Boost Configuration (Auto Triggers Enabled)**

1. Momentarily press the Red "Test" button **TWO** times. The Status LED on the module will flash a 2-2 code (two short flashes, a pause, and two more short flashes).
2. The vehicle RPM will increase to the currently configured setting.
3. To raise the RPM by 50, momentarily ground pin 1 on the 4-pin connector until the desired RPM is set.
4. Press the Red "Test" button **TWO** more times until no LED's are lit on the module.

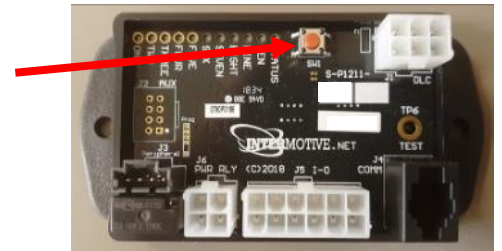

- **Default Configuration**

1. Momentarily press the Red "Test" button **THREE** times. The status LED on the module will flash a 3-3 code (three short flashes, a pause, and three more short flashes).
2. The vehicle RPM will increase to the currently configured setting.
3. To raise the RPM by 50, momentarily ground pin 1 on the 4-pin connector until the desired RPM is set.
4. Press the Red "Test" button **ONE** more time until no LED's are lit on the module.

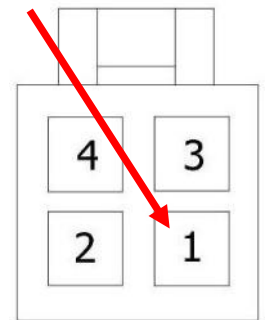

Back of Connector

Instructions

LEAVE IN VEHICLE

GTWY519/520 Fast Idle, Shift Interlock, I/O Operating Instructions 2020 - 2024 Ford Transit (B-) 2022-2023 Ford Transit w/Sync 4 (G-)

Gateway 519/520 Operation:

The Gateway 519/520 initializes when the vehicle ignition is on. During initialization, LED display panels connected to the Gateway 519/520 perform a prove-out for 2 seconds. After the initialization, the Gateway 519/520 requests various vehicle data by sending data request messages across the OEM CAN diagnostic data network and all control logic is performed. When the Gateway 519/520 module has been running and the vehicle ignition is turned to the off or accessory positions, the module goes into a low current consumption “sleep” mode. This may take up to 5 minutes.

The Gateway 519 module obtains data from the onboard vehicle data port. In order to not interfere with a possible scan tool communication, the Gateway 519/520 will refrain from transmitting CAN messages for 10 seconds if a scan tool CAN communication is detected. If during these 10 seconds another scan tool message is received, an additional 10 seconds will be added to the end of the first 10 second timeout. When no scan tool messages have been received for at least 10 seconds, the Gateway 519 module will restart communication.

Advanced Fast Idle (Optional)

The Advanced Fast-Idle System (AFIS) option of the Gateway 519/520 includes Charge-Protect as well as Fully-Automatic and Manual engage modes. Charge-Protect is a feature that maintains vehicle charging system voltage by increasing and controlling vehicle idle speed when necessary. Whenever charging system voltage falls below a minimum voltage (determined by each bus manufacturer), this AFIS feature will increase idle speed and maintain Fast Idle until one of the safety conditions is no longer met or the voltage is raised above the minimum level plus 0.5V. The Fully-Automatic and Manual engage modes also require that all safety conditions are met.

Safety conditions that must be met to engage or maintain Fast Idle operation

Vehicle NOT moving (speed = 0 MPH).

Service Brake NOT pressed.

Vehicle Transmission Range in Park

RPM inside of safe operating range.

Transmission Fluid Temperature below 250° F.

Engine Coolant Temperature below 230° F.

Control/Display Panel:

The left side of the Control/Display Panel consists of one LED and a Manual Engage Switch. The green LED will illuminate when Fast Idle is in progress. When the vehicle’s ignition switch is first turned on, the LED will illuminate for 2 seconds as a prove out of proper LED operation. The LED is also used for diagnostic code retrieval by an authorized service technician. The Manual Engage Switch can be used to engage Fast Idle operation if the voltage is above the minimum level and all safety conditions are met.

Instructions

Fast Idle Operation

Fast Idle may be initiated by either a manual or automatic Fast Idle trigger. The AFIS strategy can only command elevated idle when certain safety conditions are met (see previous section). Fast Idle operation can be terminated by a safety condition violation, or an automatic Fast Idle disengagement trigger. An automatic Fast Idle disengagement trigger will only act if the vehicle is in the particular type of automatic Fast Idle corresponding with the disengagement trigger. If an automatic Fast Idle is in progress and an automatic Fast Idle disengagement trigger occurs that would cause the Fast Idle to cease, yet there is a different pending automatic Fast Idle trigger, Fast Idle operation will NOT cease. In this case, automatic Fast Idle will continue under the new automatic Fast Idle triggering condition. If a Fast Idle Operation terminates due to an automatic Fast Idle disengagement trigger, automatic Fast Idle is available pending another automatic trigger. If a Fast Idle operation terminates due to a safety condition violation, automatic Fast Idle is unavailable until Park is de-asserted and re-asserted (shift out of Park and back into Park). The base Fast Idle RPM level is determined by the type of engine (Gas or Diesel) in the vehicle. For Gas engine vehicles, the idle speed is 1500 RPM and may be increased in increments of 100 RPM by subsequent presses of the manual engage button up to a maximum of 2000 RPM. Diesel applications remain fixed at 1200 RPM.

Manual Fast Idle Start Triggers:

Manual Engage Switch.

Fast Idle Input – ground applied to 12 Pin connector Pin #10 of the Gateway 519/520 Module, such as an input from Coach AC. (OPTIONAL)

Automatic Fast Idle Start Triggers:

Charge Protection - Battery voltage stays below minimum voltage for 2 seconds and engine running for 5 seconds.

Chassis A/C Boost - OEM A/C commanded on with ambient temperature above 70° F and engine running for at least 5 seconds.

Heater Boost – Ambient air temperature below 70° F and Engine Coolant Temperature below 170° F.

Fast Idle Disengagement Triggers:

Safety Condition Violation.

Battery Voltage > 0.5 volts above minimum voltage setting (Automatic Fast Idle Disengagement Trigger – Active only in Charge Protect mode).

Engine Coolant Temperature > 170° F (Automatic Fast Idle Disengagement Trigger – Active only in Heater Boost mode).

Open or battery voltage on 12 Pin connector Pin #10 while in Fast Idle caused by 12 Pin connector Pin #10 fast idle input. (OPTIONAL)

Transmission Fluid Temperature above 250° F.

Ambient Temperature below 70° F (Only in A/C Boost).

Note: Fast idle will temporarily stop anytime the brake pedal is depressed, but will automatically reengage after approximately 2 seconds once the brake pedal is released. Fast idle may be manually cancelled by depressing the service brake pedal while simultaneously pressing the manual engage switch.

Instructions

Fast Idle Manual Operation:

To manually engage Fast Idle, press the Yellow ENGAGE button for at least a quarter second and release. The Fast Idle operation will begin when the button is released, not when first pressed. Holding the switch for more than five seconds will initiate a diagnostic routine that displays stored status codes from previous operations. If the driver accidentally enters this routine, it can be exited by cycling the vehicle's ignition off and then back on. To exit Fast Idle operation, the driver can simply depress the service brake pedal while simultaneously pressing the manual engage switch.

Note: When additional electrical or A/C loads are in use, engine RPM may drop. The AFIS feature will then raise the RPM back up to the fast idle speed. When the load is removed, engine RPM will increase. AFIS will then lower the RPM back to the fast idle speed. This may be more noticeable on cold engine startup.

Lift Operation

The Intelligent Lift Interlock System of the Gateway 519/520 is a microprocessor driven system for controlling wheelchair lift operation. Lift operation will only be allowed when all of the following conditions are met:

- The vehicle is in "Park"
- The Parking Brake is applied
- The vehicle ignition is On
- The lift door is open
- Lift inhibit is not activated

The Gateway 519/520 will not allow the vehicle to be shifted out of park if the lift door is open. The vehicle can be shifted out of park if only the passenger door is open. As an added feature, it will not allow the vehicle to be shifted out of park when the parking brake is applied. This feature eliminates excessive parking brake wear due to driving with the parking brake applied. The shift lock can also be activated through the 12 Pin connector Pin #10, if the proper configuration is installed .

If the vehicle has Daytime Running Lights, they will be activated when the Lift Door is Open and/or the Park Brake is On and the Ignition key is On.

When the vehicle is first started, or if the key is turned to the "Run" position, the five upper LED's on the display panel will illuminate for 2 seconds as a prove out of the LED's. The lower Icon LED's are backlit and will remain illuminated whenever the Gateway 519 module is awake. The module will stay awake for several minutes after the ignition is turned off. After prove out, the operation of the LED panel is as follows:

Vehicle Secure – Illuminates in green if the lift is enabled. This means that all conditions for lift operation have been met and the lift has been supplied a vehicle secure signal.

Park Brake – Illuminates in red when the parking brake is applied.

Park - Illuminates in red when the vehicle transmission is in the park range.

Door Open - Lift Door Display Panel only- Illuminates in red when the lift door is open.

Door Ajar - Door Ajar Display Panel only- Illuminates in red when the lift door is open, flashes in red when the passenger door is open.

Shift Lock - Illuminates in Red when the lift door is open and/or the parking brake is applied. It can also be illuminated from an external command through the I/O 4 input at Pin #10 of the 12 pin connector, if the proper configuration is installed. When illuminated, the driver will not be allowed to shift out of park.

All five Interlock LED's must be illuminated for the Wheelchair Lift to operate

Instructions

GTWY 519/520 Additional Options Operating Instructions

Door AJAR:

- When an additional door is open, the Door Ajar LED will blink on the display panel until the door is closed.
- The **Gateway 520** will flash the Door Ajar LED when any of the doors are opened.
- If the Lift Door is open, the Door Ajar LED will stay on steady, taking priority over the additional door input.



If the GTWY519/520 fails any step in the System Operating instructions review the instructions.
If necessary, call InterMotive Technical Support at (530) 823-1048.

B-GTWY519/520

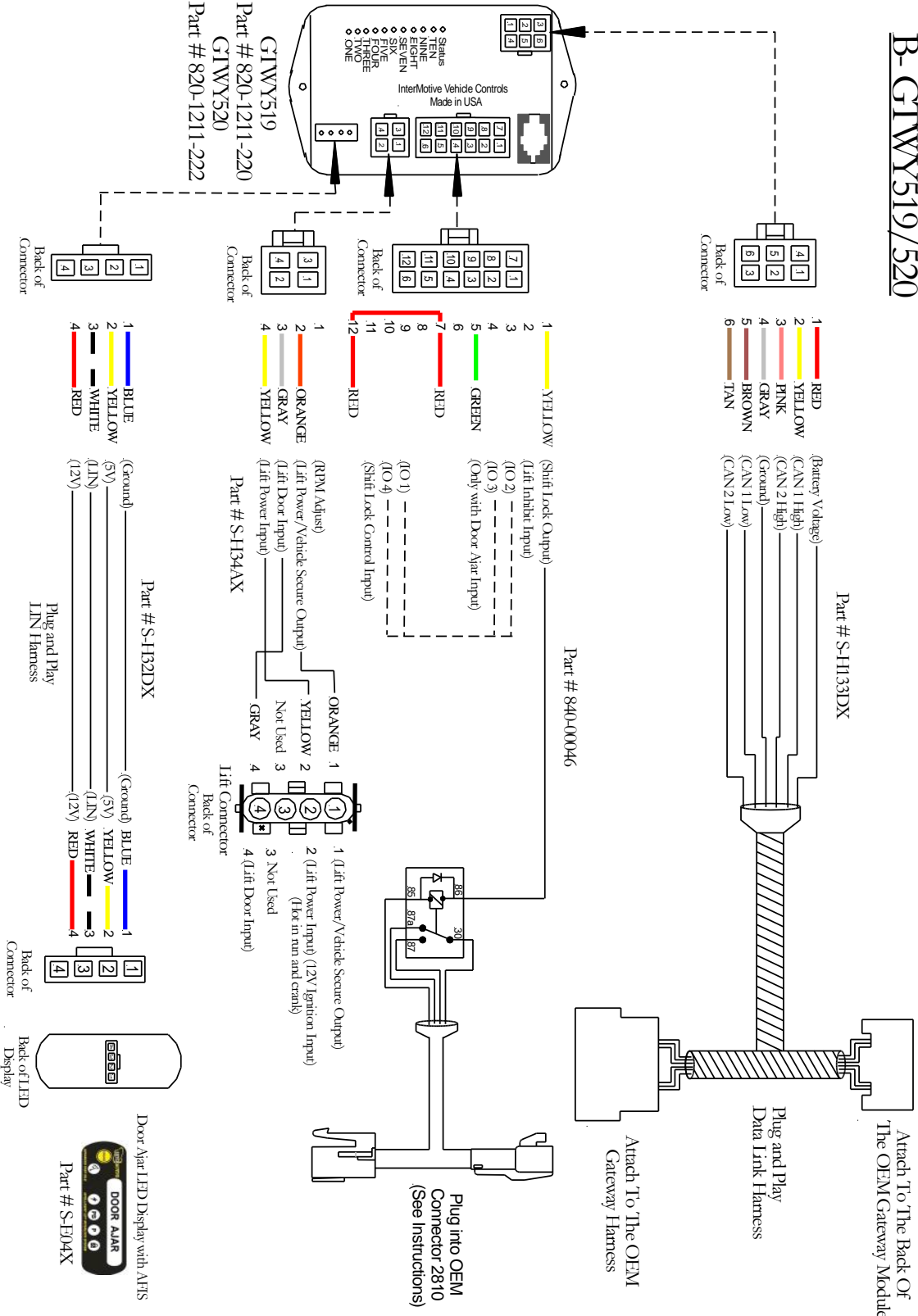

Submit product registration at www.intermotive.net

If the GTWY519/520 fails any step in the Post Installation Check List, review the installation instructions and check all connections. If necessary, call InterMotive Technical Support at (530) 823-1048.

G-GTWY519/520

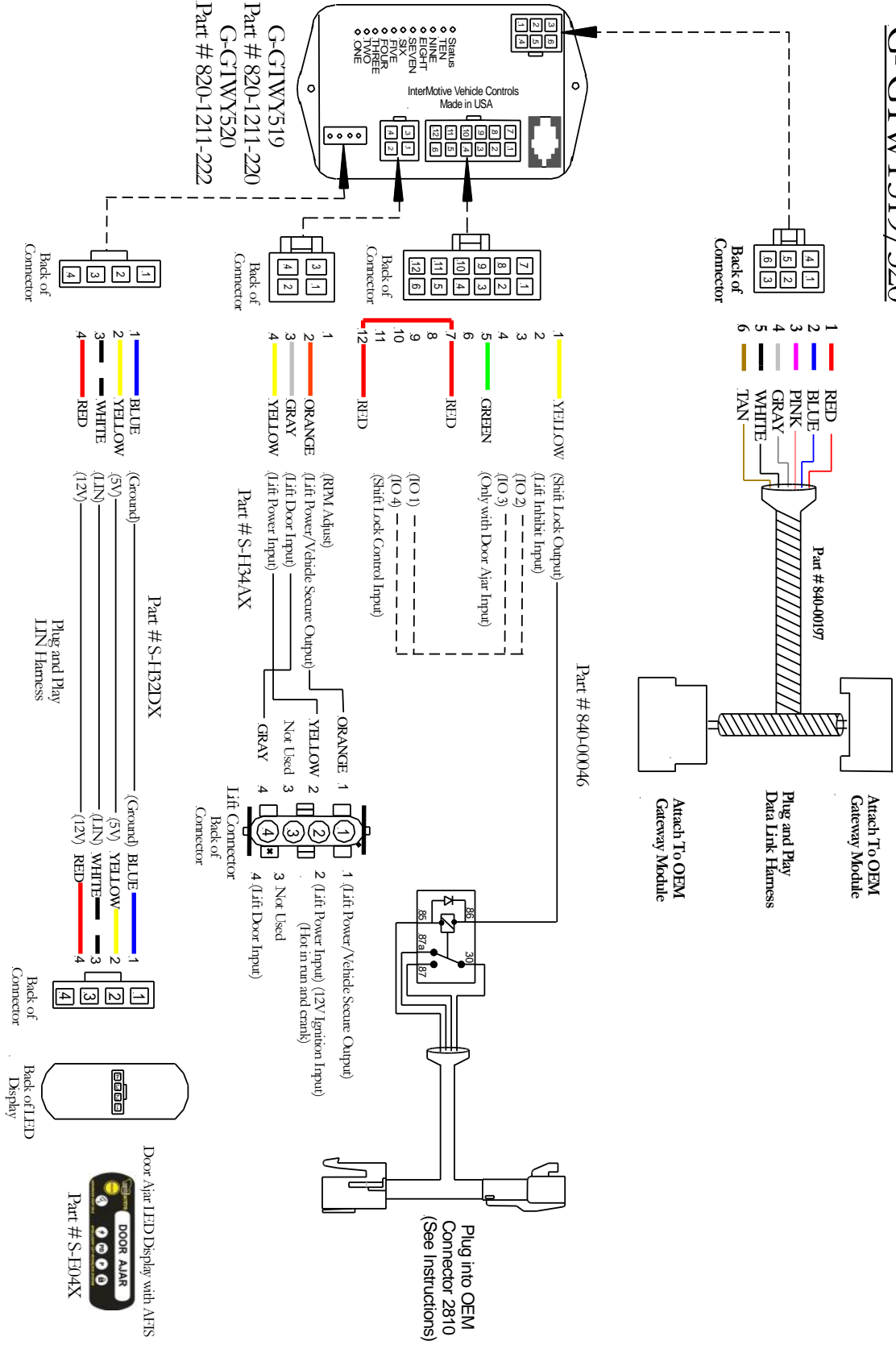

Submit product registration at www.intermotive.net

If the GTWY519/520 fails any step in the Post Installation Check List, review the installation instructions and check all connections. If necessary, call InterMotive Technical Support at (530) 823-1048.