

G-IDLE506-A
Idle Lock™ Anti-Theft
2022 Ford F250-F600 for Sync 4 (12" display)
Contact InterMotive for additional vehicle applications.



Introduction

Idle-Lock is an anti-theft system that allows the engine to idle with the key removed from the ignition and the shifter locked in park. The system is activated by pressing a momentary enable switch and removing the key within three seconds. If the service brake is pressed while in Idle-Lock mode the horn will sound as an alarm.

CAUTION

All electronic products are susceptible to damage from Electrostatic Discharge or ESD. Ground yourself before handling or working with the module and harnessing by first touching chassis ground, such as the barrel of the cigarette lighter.



Installation Instructions

Disconnect vehicle battery before proceeding with installation



WARNING
Disconnect the battery to prevent setting a check engine light.

It is the installer's responsibility to route and secure all wiring harnesses where they cannot be damaged by sharp objects, mechanical moving parts and high heat sources. Failure to do so could result in damage to the system or vehicle and create possible safety concerns for the operator and passengers. It is important to avoid placing the module where it could encounter strong magnetic fields from high current cabling connected to motors, solenoids, etc. Also avoid radio frequency energy from antenna's or inverters next to the module. Finally, avoid high voltage spikes in vehicle wiring by always using diode clamped relays when installing upfitter circuits.

G-IDLE506-A Module

Remove the lower dash panel below the steering column and find a suitable location to mount the module. Locate the module in an area away from excessive heat sources (engine, heater ducts, etc.). Ensure when routing harnesses that the tilt steering column does not contact them in the full down position. When installing the harnesses, leave several inches of take-out such that the module can be removed if necessary. Do not mount the module until all wire harnesses are routed and secure. The last step of the installation is to mount the module.

Installation Instructions (continued)

Gateway Plug and Play Harness (6-pin connector)

1. Locate the vehicles Gateway Module. It will be mounted behind the glove compartment.
2. Press the tabs inward on the sides of the glove compartment and fully lower it.
3. Remove the 3 nuts securing the Gateway module to the vehicle.
4. Remove the 26-pin connector from the side of the Gateway module and plug into the mating connector on the G-IDLE506 harness.
5. Plug the male 26-pin connector from the G-IDLE506 harness into the Gateway module.
6. Reinstall the Gateway module and the glove compartment.
7. Plug the free end of the Data Link harness into the mating 6-pin connector on the G-IDLE506 module.

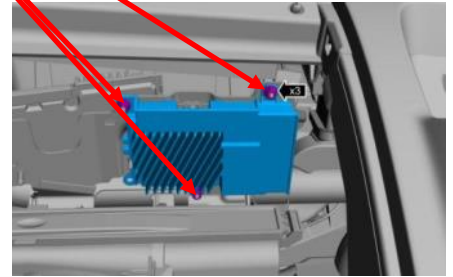

Shift Lock Harness

1. Remove the upper and lower steering column covers by removing the 3 screws in the lower column cover.
2. Locate the Shift Lock (4-pin) harness.
3. Unplug the Shift Lock connector.
4. Plug the OEM Shift Lock connector into the mating connector on the G-IDLE506-A harness.
5. Plug the 4-pin connector on the G-IDLE506-A harness into the mating connector on the OEM Shift Lock harness.
6. Leave the upper and lower steering column covers off until the ignition switch harness is attached. (instructions on the next page)

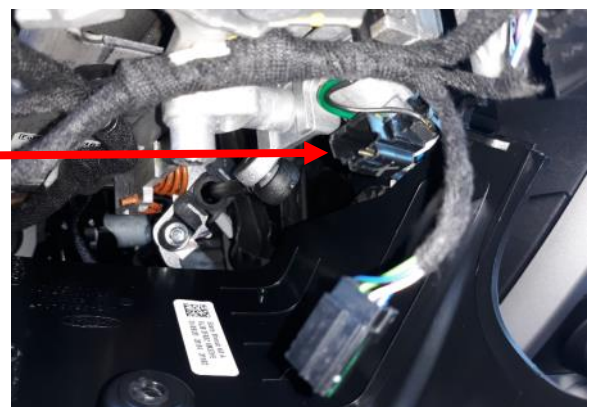

Ignition Switch Harness

1. Locate the 7-pin ignition switch connector (C250) on the steering column and disconnect it from the ignition switch.
2. Install the Idle-Lock harness between the Ignition Switch and the OEM connector.

Front of C250 Connector

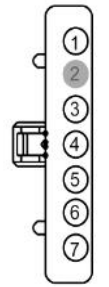

I/O Wiring, Features, and Descriptions: (Solder and heat shrink all connections)

Shift Lock

Pin 3, Yellow wire of the 12-pin connector will connect to the OEM shift lock solenoid.

Shift Lock Request Input (Active Low)

Pin 3, Green-White wire of the 4 pin connector is the Shift Lock Request Input. This input could be connected to the rear door switch to lock the shifter in park if the door is open.

Shift Lock Request Override Input (Active Low)

Pin 5, Pink wire of the 12 pin connector is the Shift Lock Request Override Input. This input should be connected to a momentary switch that will override shift lock due to the Shift Lock Request Input. This input will allow the operator to temporarily override shift lock to shift the transmission out of park in the event of a bad door switch. It will only allow override if the key is in the ignition and the switch turned to the run position. **InterMotive strongly recommends installing this switch.**

Lock Output (Active High)

Pin 2, White wire of the 12 pin connector is the Idle-Lock output. This output (500mA max current) can control installer supplied normally closed relays to lock/disable equipment when Idle-Lock is active. This minimizes possible theft when Idle-Lock is active and the vehicle is unattended.

When Idle-Lock is enabled, this output becomes active after 10 seconds. This output remains active until the key is back in the run position.

Idle-Lock Active Output (Active High)

Pin 11, Yellow wire of the 12 pin connector is the Idle-Lock Active output. This output (500mA max current) can control installer supplied normally closed relays or auxiliary indicator LEDs. When Idle-Lock is enabled, this output becomes active. This output remains active until the key is back in the run position. Mounted in an appropriate location these indicators will allow the operator to easily determine if Idle-Lock mode is active.

Horn/Alarm Output (Active Low)

The G-IDLE506 provides a horn/alarm output that can be connected to the OEM horn circuit to activate the OEM horn or an alarm when the Service Brake is pressed while in Idle-Lock mode.

Pin 8, Orange wire of the 12 pin connector is the Horn/Alarm Output. This output (500mA max current) can control the OEM horn relay or an installer supplied alarm.

Idle-Lock Enable Switch and Active LED

An LED is provided in the kit which illuminates when Idle-Lock is active.

1. Drill a 16mm (0.630") hole in the desired mounting location. One possibility is the dash panel to the left of the Steering Wheel.
2. Route the LED harness through the hole and mount the LED in the hole.
3. Slide the LED's lock nut onto the harness and snug it down onto the back of the LED.
4. Plug in the 4 pin (Black) connector of the LED harness into the mating connector on the Idle-Lock main harness.
5. Apply optional "Idle-Lock Enable/Active" label included in the kit.

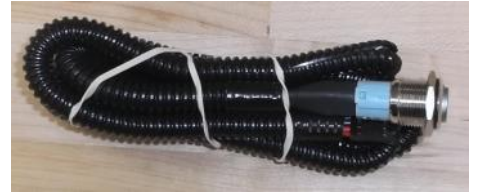

G-IDLE506 Module Mounting

Ensure all harnesses are properly connected and routed, and are not hanging below the dash area. Mount the module as described on page one and secure with supplied screws or double sided tape.

G-IDLE506 Harness (4 Pin connector and 12 Pin connector)

1. Plug the G-IDLE506 4 Pin connector into the mating 4 pin connector on the G-IDLE506 module.
2. Plug the G-IDLE506 12 Pin connector into the mating 12 pin connector on the G-IDLE506 module.

Reconnect the vehicle battery

Post Installation Operational Test

Test 1. Start the Engine.

Test 2. While the engine is running, enable Idle-Lock by asserting the enable request input.

- The Red LED will flash five times and then blink every two seconds.
- Remove the key from the ignition within 3 seconds, the engine will continue to idle.
- Idle-Lock is now active.

Test 3. Attempt to shift the vehicle out of Park. The system will keep the shifter locked. At this time the OEM horn may sound (if wired) for 20 seconds after the service brake is pressed or until the key is turned to the run position.

Test 4. Verify that the Lock Output disables/locks equipment at the proper times (if wired).

Test 5. Insert key and turn to RUN. The vehicle should be able to shift out of Park.

- The system will deactivate (shut down engine) if anyone defeats the OEM shift lock mechanism and shifts the vehicle out of Park.

If the system fails any of the above tests, check the related wiring. If necessary, call InterMotive Technical Support at 530-823-1048. Do NOT release vehicle for service unless it has passed ALL of the above tests.

G-IDLE506-A
Idle Lock™ Anti-Theft
2022 Ford F250-F600 for Sync 4 (12" display)
Contact InterMotive for additional vehicle applications.



Idle-Lock is an anti-theft system that allows the engine to idle with the key removed from the ignition and the shifter locked in park. The system is activated by pressing a momentary enable switch and removing the key within three seconds. If the service brake is pressed while in Idle-Lock mode the horn may sound as an alarm. (if wired) The system also provides a shift lock request input that can be used as an interlock for the rear door.

- Idle-Lock is enabled by removing the key from the ignition within 3 seconds of asserting the Idle-Lock enable input. Transmission must be in Park and engine must be running.
- To prevent unattended vehicle theft (Idle-Lock active), the horn may sound (if wired) if someone attempts to shift the vehicle out of Park. The shifter will remain locked, and the Lock Output will remain active.
- Inserting the key and turning it to Run restores normal operation. The Lock Output will turn off.
- The system may have an input to lock the shifter if the rear door is open. A momentary override switch will be installed to bypass shift lock due to the rear door in the case of a faulty door switch.

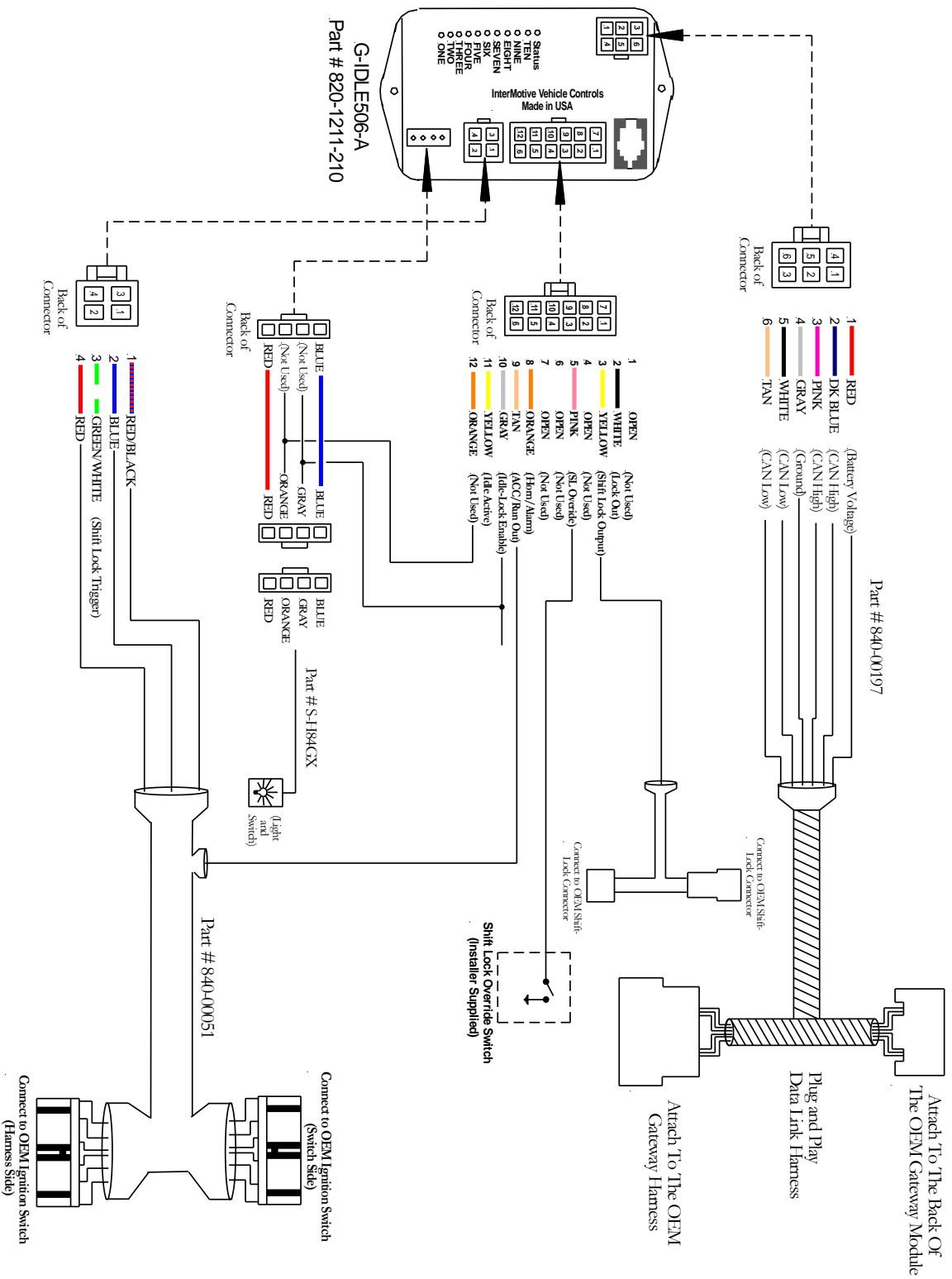

Submit product registration at www.intermotive.net

If the Idle-Lock 506 fails any step in the Post Installation Test, review the installation instructions and check all connections. If necessary, call Intermotive Technical Support at (530) 823-1048.