

Engine Monitor System
2009 - 2019 Ford E Series (A-EMS501-D)
2011 - 2016 Ford F250-F550 6.2L, 6.8L (EMS507-D)
2017 - 2022 Ford F250-F550 6.2L, 6.8L, 7.3L (B-EMS507-D*)
2020 - 2021 Ford Transit (B-EMS507-D*)
2021 - 2025 Ford E-Series (B-EMS507-D*)
*Uses the Ford 24-pin Data Link Harness



Introduction

The Engine Monitor System continuously monitors several engine and transmission parameters. If any one of these parameters fall outside of its safe operating range, the EMS initiates a Shutdown warning. After sounding a warning and flashing the LED display, the system will shut off the engine when the vehicle comes to a stop. Ignition power and the fuel pump are disabled to prevent engine/transmission damage. The EMS also provides optional Engine Disable Request inputs and an Engine Disabled Confirmation output for use by auxiliary systems that require engine shut down (i.e. a fire suppression system). Parameters that trigger a Warning and Shutdown:

- Transmission Fluid Temperature > 300° F
- Engine Coolant Level Below Sensor (Diesel only)
- Engine Temperature > 250° F
- Low Oil Pressure
- Auxillary Engine Disable Request

The EMS records the shutdown event and the activation trigger. The ten most recent events are stored in the module's memory. To extract this information, the USB to Serial Communication cable (part number a-IPU) is required, which is purchased separately from InterMotive.

Installation Instructions

Disconnect vehicle battery before proceeding with the installation



WARNING

Disconnect the battery to prevent setting a check engine light.

IMPORTANT—READ BEFORE INSTALLATION

It is the installer's responsibility to route and secure all wiring harnesses where they cannot be damaged by sharp objects, mechanical moving parts and high heat sources. Failure to do so could result in damage to the system or vehicle and create possible safety concerns for the operator and passengers. Avoid placing the module where it could encounter strong magnetic fields from high current cabling connected to motors, solenoids, etc. Avoid radio frequency energy from antennas or inverters next to the module. Avoid high voltage spikes in vehicle wiring by always using diode clamped relays when installing upfitter circuits.

EMS50X Module

Remove the lower dash panel below the steering column and find a suitable location to mount the EMS module. Do not mount the module where it will be exposed to external heat sources (engine heat, heater ducts, etc.). Do not mount the module until all wire harnesses are routed and secure. The last step of the installation is to mount the module. When installing the harnesses, leave several inches of take-out in order to remove the module if necessary.

Data Link Harness (6-pin connector)

1. Locate the vehicle OBDII Data Link Connector, mounted below the lower left dash panel.
2. Remove the mounting screws for the OBDII connector. Plug the red connector from the EMS Data Link Harness into the vehicle's OBDII connector. Ensure the connection is fully seated and secured with the supplied wire tie.
3. Mount the black connector from the Data Link Harness in the former location of the vehicle's OBDII connector.
4. Secure the Data Link Harness so that it does not hang below the lower dash panel.
5. Plug the 6-pin "Data Link" connector into the 6-pin connector on the module.



Ford 24-pin Data Link Harness (6-pin connector)

1. Locate the vehicles Gateway Module. It will be mounted below the lower left dash panel.
2. Remove the harness behind the Gateway module by pressing the locking tab and pulling outward.
3. Plug the Female side of the Intermotive Gateway Harness into the back of the Gateway module. Ensure the connection is fully seated and secured by the locking tab.
4. Plug the Male side of the Intermotive Data Link Harness into the Gateway harness.
5. Secure the EMS50X Gateway harness so that it does not hang below the lower dash panel.

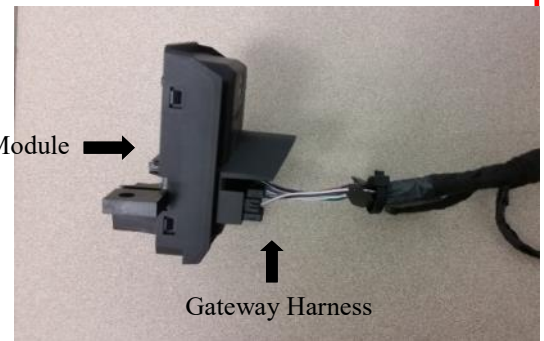

Ignition Switch Connection (4-pin connector)

1. Remove the lower steering column trim cover. Locate the appropriate ignition switch connector C250 (see below) and disconnect it from the ignition switch.
2. Install the EMS50X harness between the ignition switch and the OEM connector.
3. Plug the EMS50X 4 pin connector into the mating 4-pin connector on the EMS module.



**2009-19
E-Series
C250
Front of
Connector**

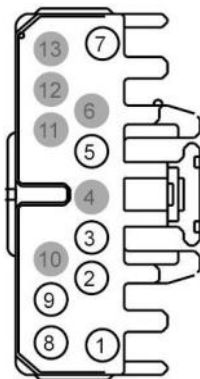

**2008-10
F-Series
C250
Front of
Connector**

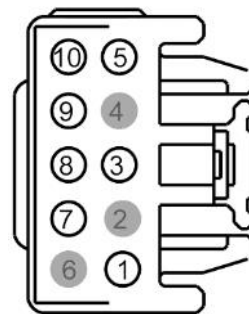

**2011-'22
F-Series,
2020-'21
Transit,
2021-'24
E-Series
C250
Front of
Connector**

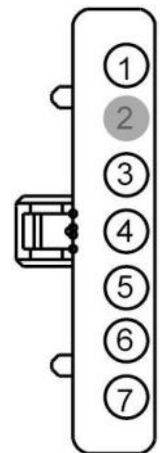

LED Display Panel

Locate a suitable position on the dashboard within view of the driver for mounting the EMS LED Display Panel. The length of the display harness is 40". This is the maximum distance the display can be mounted from the EMS module.

1. Drill a 5/8" hole in the dashboard where the center of the display will be located, being careful not to damage anything behind the dashboard.
2. Run the free end of the display harness under the dash and out through the 5/8" hole.
3. Attach the end of the display harness to the EMS LED Display Panel.
4. Ensure panel is level, and secure using the supplied screws.
5. Attach the 4-Pin EMS LED display harness to the EMS Module's 4-pin connector.

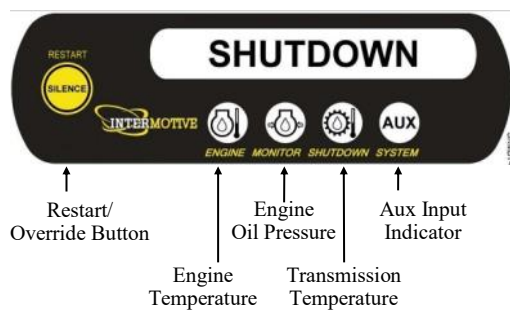

Control Outputs and Input Connections (12-pin I/O connector)

A harness with a 12-pin connector is provided with the following wires. Note that most of these signals are optional and not all of these wires will be used in any given application. Unused wires should be left as "no connects" and taped up to prevent contact. EMS kits with the "Diesel" option have green wires in pins 1 & 3. Connect the appropriate wires for your specific application. Solder and tape/heat shrink all connections.

12-pin connector pin out definition

- Pin #1 - Green - EC Sensor - Engine Coolant Level Detection Input (Diesel only)
- Pin #2 - Gray - Optional EDR Input - Engine Disable Request Input (0 V)
- Pin #3 - Green - connects to pin 1 in the harness (Diesel only)
- Pin #4 - Yellow - Optional EDR Input - Engine Disable Request Input (12 V)
- Pin #5, #6, #7 - Not Used
- Pin #8 - Orange - Warning Indicator Output. Connected to beeper.
- Pin #9 - Blue - Optional EDC Output - Engine Disabled Confirmation (12 V)
- Pin #10, #11, #12 - Not Used

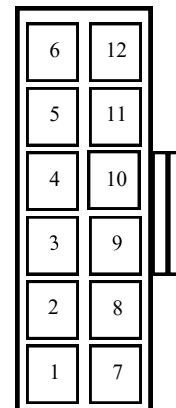

Back of the
12 Pin Connector

Engine Disable Request Input (optional)

The EMS 12-pin connector Pin #2 Gray wire can be connected to a grounding Engine Disable Request input which will activate the Engine Shutdown System and shut off the engine.

Warning: If the 12 pin connector Pin #2 Gray wire is shorted to ground, the engine will turn off when the vehicle speed equals 0 MPH.

The EMS 12-pin connector Pin #4 Yellow wire input can be connected to a 12V Engine Disable Request which will activate the Engine Shutdown System and shut off the engine. For use with auxiliary systems, such as fire suppression, that require an engine/fuel pump to be disabled before activating.

Engine Disable Confirmation Signal Output (optional)

The EMS 12-pin connector Pin #9 Blue wire will provide a 12V confirmation output when the Engine Shutdown System disables the engine. This indicates to an auxiliary system that the vehicle has been disabled.

Warning Indicator Beeper

1. Locate an accessible location to mount the warning indicator beeper so that it is audible to the driver.
2. Drill a 1 1/8 inch hole to mount the beeper.
3. Connect the EMS 12 pin connector Pin #8 Orange wire to the indicator beeper positive (+) terminal.
4. Connect the Black wire to the indicator beeper negative (-) terminal.
5. Attach the indicator beeper Black wire eyelet to a ground source.
6. Secure the indicator beeper into the hole with the supplied nut and rubber washer.



The bezel on the beeper can be rotated for volume control

EMS Module

Ensure all the harnesses are properly connected and routed, and are not hanging below the dash area. Mount the EMS module as described on page one and secure using screws or double sided tape.

Reconnect vehicle battery

Post Installation Testing

THE FOLLOWING PROCEDURE MUST BE PERFORMED TO VERIFY PROPER INSTALLATION:

1. Place transmission in Park and set Park Brake. Start the engine.
2. Verify the four lower LEDs prove-out on the LED Status Panel. All four (4) lower LEDs will illuminate for approximately two seconds upon initial power on. The Shutdown LED does not prove out.
3. Push and hold down the yellow Restart/Silence button for 10 seconds to enter test mode. Release the button once the warning sounds
4. The Shutdown LED will flash and Beeper will sound for three seconds.
5. The Shutdown LED will illuminate solid and the engine will shut down.
6. Push and release the Restart/Silence button to restore ignition function.
7. Restart the vehicle. Test drive vehicle, maintaining a speed above 5 MPH.
8. While driving the vehicle, push and hold down the Restart/Silence button for 10 seconds to enter test mode.
9. Briefly push the Restart/Silence button to silence the beeper.
10. In a safe area, slow the vehicle speed to 0 MPH. Verify the Shutdown LED illuminates solid and the engine shuts down.
11. Place vehicle in Park. Push the Restart/Silence button to regain ignition control. Verify engine starts.
12. In vehicles with auxiliary systems connected to EMS to request engine shut down, a shutdown request can be simulated by either grounding the pin #2 gray wire, or applying 12V to pin #4 yellow wire. Verify the system shuts down the engine when requested.

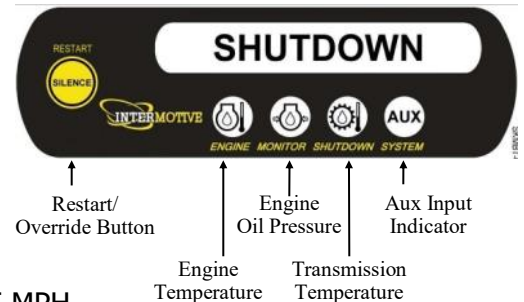

**The EMS50X is properly installed only if it passes all of the above steps.
If any irregular operational issues persist, contact InterMotive at 530-823-1048 for technical assistance.**

Leave in vehicle
Operating Instructions Engine Monitor System
2009 - 2019 Ford E Series (A-EMS501-D)
2011 - 2016 Ford F250-F550 6.2L, 6.8L (A-EMS507-D)
2017 - 2022 Ford F250-F550 6.2L, 6.8L, 7.3L (B-EMS507-D*)
2020 - 2021 Ford Transit (B-EMS507-D*)
2021 - 2025 Ford E-Series (B-EMS507-D*)
***Uses the Ford 24-pin Data Link Harness**

System Operation

The Engine Monitor and Shutdown System gathers specific engine and transmission information and initiates a warning and engine shutdown sequence if any problems are observed. The Engine Monitor System will NOT shut the engine off if the vehicle is in motion. The system consists of the control module, a remote buzzer for audible notification, an LED panel with several indicators, and a "silence" button for the buzzer.

When the ignition is turned on, the EMS module powers up and the four LEDs along the bottom row illuminate for several seconds. Once prove out is complete, the module begins monitoring the vehicle's internal data network. It uses this information to determine whether operating conditions are safe or potentially damaging to the vehicle. If any parameters are outside of the normal operating range, the EMS50X module will issue a shutdown warning which consists of beeping and flashing the LED panel. **It is extremely important that the operator get the vehicle to a safe area before bringing the vehicle to a complete stop.** Once the vehicle comes to a stop, EMS removes ignition power, shutting off the engine and preventing further damage to the vehicle.

Additionally, there are several inputs to the EMS system which can allow auxiliary equipment to shut the engine down (i.e. fire suppression systems).

When the vehicle's Ignition Switch is shut off in normal operation, the EMS module will enter a low power sleep mode within several seconds.

The EMS records the shutdown event and the activation trigger. The ten most recent events are stored in the module's memory. To extract this information, the USB to Serial Communication cable (part number a-IPU) is required, and can be purchased separately from InterMotive.

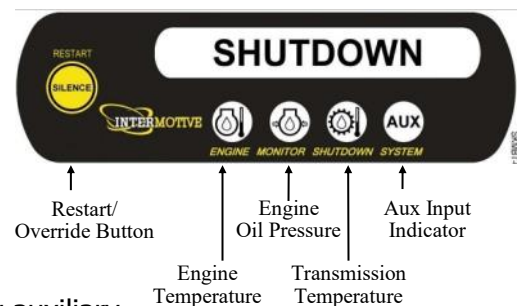

Engine Shutdown initiation will be triggered due to any one of the following conditions:

- Engine Temperature is greater than 250° F will illuminate Engine temperature LED.
- Engine Coolant level below sensor level. (Diesel only) will flash Engine temperature LED.
- Engine Oil Pressure low pressure will illuminate Oil Pressure LED.
- Transmission Fluid Temperature greater 300° F will illuminate Transmission Temperature LED.
- Auxiliary Engine Disable Request input applied will illuminate Auxiliary LED.

Engine Shutdown Sequence

- One or more of the filtered threshold value(s) are exceeded and confirmed.
- A warning beep and flashing LED panel notifies the driver that a shutdown sequence has been initiated and the LED display indicates which trigger has been activated.
- The EMS continues to monitor vehicle speed. Once the filtered vehicle speed is zero, the engine is shut off. **It is highly important that the operator get the vehicle to a safe area before bringing the vehicle to a complete stop.**
- The EMS records the shutdown event and the activation trigger. The ten most recent events are stored in the module's memory. This information can be extracted and viewed as explained below.

Viewing EMS Shutdown Record

To extract this information, the USB to Serial Communication cable (part number a-IPU) is required, which is purchased separately from InterMotive.

Follow these steps to view the record of the 10 most recent engine shutdown events:

- Ensure that the proper laptop drivers are installed for the USB to Serial Communication cable provided by InterMotive. All driver files are located online at: <http://www.ftdichip.com/Drivers/VCP.htm>
 - Find the correct drivers for your system and follow the steps to download the latest version (located under the "Driver Version" heading). If unsure about the installation process, contact InterMotive for further assistance.
 - Once the installation process is complete, plug the Communication cable into one of the computer's USB ports.
1. Ensure the vehicle's key is off and plug the other end of the download cable into the EMS50X port labeled 'COMM'.
 2. Open the Windows communication application HyperTerminal. This program can be found under: Start > All Programs > Accessories > Communications > HyperTerminal.
 3. A prompt comes up to give this connection setup a name. It's suggested to use something meaningful such as "EMS Viewer".
 4. The next window will prompt to select the COM port for this connection. Typically, the highest numbered COM port will be the InterMotive Communication cable.

Note: This can be double-checked on Windows XP by right-clicking on 'My Computer' and selecting 'Properties.' From this window, select the 'Hardware' tab and click on 'Device Manager.' In the Device Manager window, expand the 'Ports' menu and the download cable will display as 'USB Serial Port.'

Viewing EMS Shutdown Record (continued)

1. In the next window, several of the default parameters for the Port Settings need to be changed. Change the Bits per second to: **57600**, Data bits: **8**, Parity: **None**, Stop bits: **1**, and Flow control: **None**. HyperTerminal setup is now complete.
2. Turn the vehicle key to the ON position. The EMS module will wakeup and text will display on the open HyperTerminal window.
3. If nothing appears, unplug the 6 pin connector going into the EMS module, wait several seconds and plug the connector back in.
4. If still nothing appears, go to File > New Connection and re-configure the HyperTerminal as described above. If unsuccessful, contact InterMotive for further assistance.
5. With communication established, type in the words "get data" followed by the enter key. A record of the 10 most recent engine shutdown events will display
6. The screen data can be captured to the Windows clipboard for later printing by using the Edit copy command.
7. When finished, key off and disconnect the Communication cable.

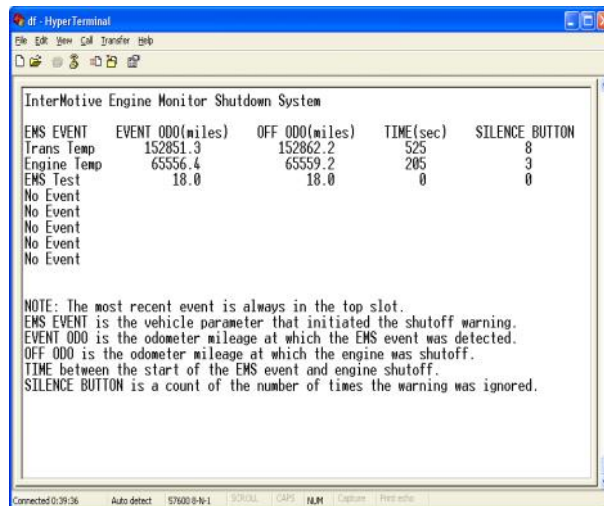

The screenshot shows a HyperTerminal window titled "df - HyperTerminal" with a menu bar (File, Edit, View, Call, Transfer, Help) and a toolbar. The main display area shows the following text:

```
InterMotive Engine Monitor Shutdown System
```

EMS EVENT	EVENT ODO(miles)	OFF ODO(miles)	TIME(sec)	SILENCE BUTTON
Trans Temp	152851.3	152862.2	525	8
Engine Temp	65556.4	65559.2	205	3
EMS Test	18.0	18.0	0	0
No Event				
No Event				
No Event				
No Event				
No Event				

NOTE: The most recent event is always in the top slot.
EMS EVENT is the vehicle parameter that initiated the shutoff warning.
EVENT ODO is the odometer mileage at which the EMS event was detected.
OFF ODO is the odometer mileage at which the engine was shutoff.
TIME between the start of the EMS event and engine shutoff.
SILENCE BUTTON is a count of the number of times the warning was ignored.

At the bottom of the window, a status bar shows: "Connected 0:39:36 Auto detect 57600 8-N-1 30000 CAPS NUM | Capture Print edit"

2009-2019 Ford E-Series Plug and Play

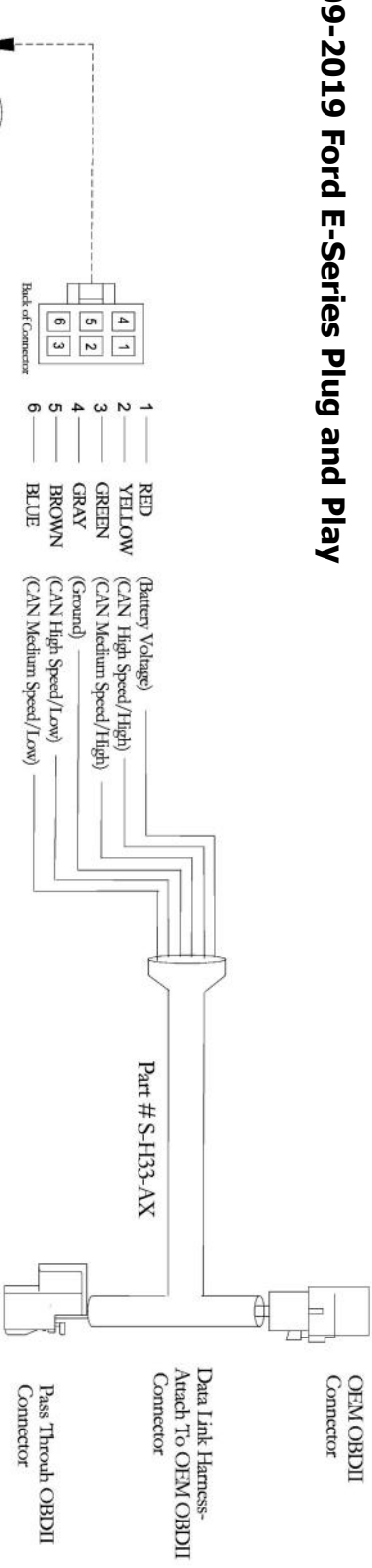

Part # S-H48-AX

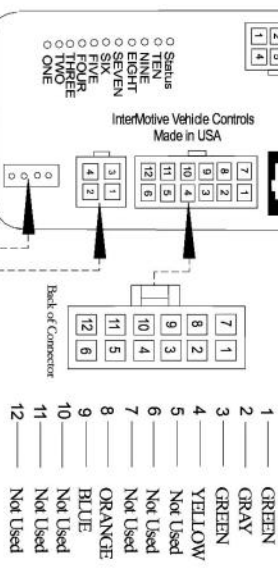

Part # S-H44-PX

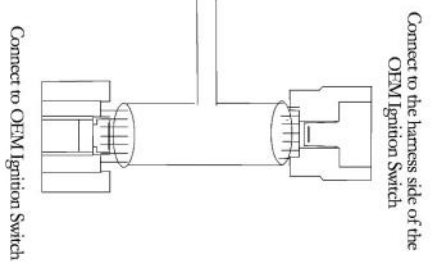

EMMS501-D Module
S-M1200-30B

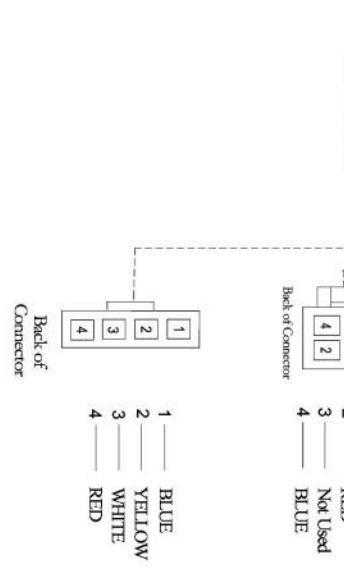

Part # S-H32-DX

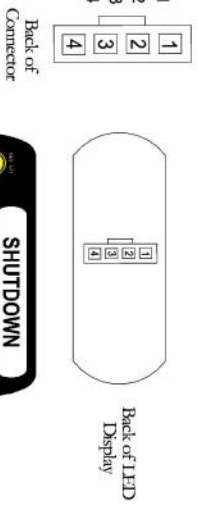

Part # S-ED5X



Submit product registration at www.intermotive.net

If the EMS50X fails any step in the System Operation Test, review the installation instructions and check all connections. If necessary, call InterMotive Technical Support at (530) 823-1048.

2011 - 2022 Ford F-250-F550 Plug and Play 2020 - 2021 Ford Transit Plug and Play 2021 - 2025 Ford E-Series Plug and Play

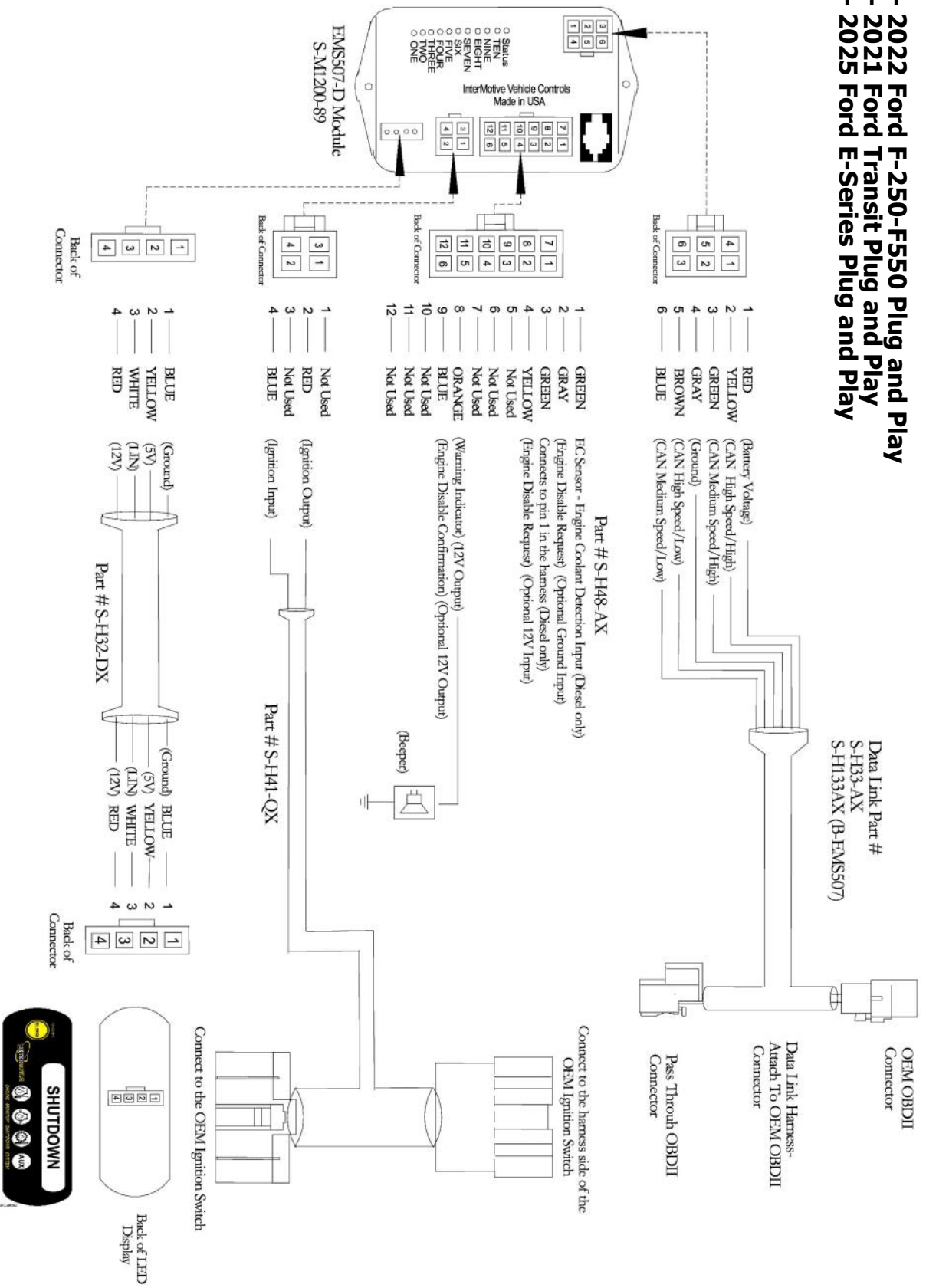

Submit product registration at www.intermotive.net

If the EMS50X fails any step in the System Operation Test, review the installation instructions and check all connections. If necessary, call InterMotive Technical Support at (530) 823-1048.