

Emergency Door Module - EDM603-GD-B

GM/Chevy 560 – 2005-2009

GM/Chevy 610 – 2008-2016

Introduction

The Emergency Door Module will prevent the vehicle from starting unless the rear emergency door is closed *and* unlocked. An audible alarm will sound anytime the door is open while the ignition is on.

Installation Instructions

Disconnect vehicle battery before proceeding with installation



WARNING
Disconnect the battery to
prevent setting a check engine
light.

GM/Chevy 560

Locate the vehicle start circuit by removing the #1 instrument panel fuse block from its mounting bracket. It is located on the right side of the instrument panel under the access cover. Rotate the fuse block to view the back, (See diagram). Locate the Purple wire in Cavity # L5. Cut this wire.

Red Wire – Locate the Pink wire in Cavity # J5 of the #1 instrument panel fuse block. **Do not cut this wire.** Attach the red wire in parallel to this circuit by stripping the insulation, soldering, and taping.

Yellow Wire – Attach the female 2-pin connector, Pin #2 Yellow wire to the fuse block side of the Purple wire.

Blue Wire – Attach the male 2-pin connector, Pin #2 Blue wire to the other end of the Purple wire.

2005-2009 GM/Chevy 560 Fuse Block Diagram

Pin	Wire Color	Circuit No.	Function
J5	PK	39	Ignition 1 Voltage
L5	PU	806	Crank Voltage

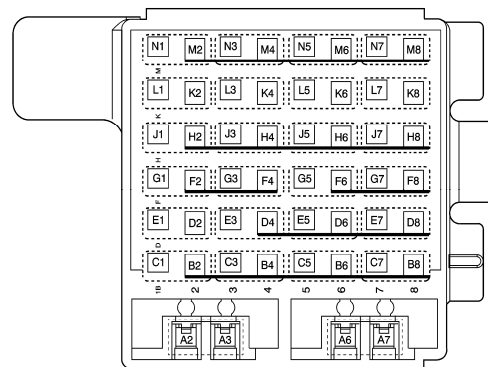

EDM603-GD-B Module Mounting

1. Locate an area behind the lower dash panel to mount the EDM603-GD module. Do not block the opening in the module or the alarm volume will be reduced. The module can be mounted using supplied screws or double sided tape
2. **Attach the Black wire to a known good ground point.** Snap the 4-pin vehicle harness installed above into the module 4-pin connector. The Back 2 pin Weather-Pack connector will attach to the door circuits. **NOTE:** The mate to this connector is not included. The mating connector is Part # 12010973-B. The Terminals are Part # 12124582-L. The connector seals (Optional) are part # 12015323-B.
3. Connect the White wire to the door open switch. This circuit must provide a ground when the door is open.
4. Connect the Green wire to the door lock switch. This circuit must provide a ground when the door is locked.

Reconnect vehicle battery.

GM/Chevy 610 – 2008-2009

Locate the main fuse box on driver's side of engine compartment. Rotate the fuse block for access. Open main wire harness and locate start circuit wire (Yellow with Black tracer). This circuit is pin 85 of the Crank relay (#73).

Determine which side of the circuit is the start circuit input and which is the output to starter. Run harness (Yellow and Blue) through bulkhead using a grommet to prevent chafing.

Red Wire – Locate the Black 4-way connector under dash (Fig. 1). Attach the Red wire to the Pink wire (pin B) in parallel to this circuit by stripping the insulation, soldering, and taping (Fig. 2).

Yellow Wire – Attach the **female** 2 pin connector Pin #2 Yellow wire to the starter input. Solder and heat shrink this connection.

Blue Wire – Attach the **male** 2 pin connector Pin #2, Blue wire to the starter output. Solder and heat shrink this connection.

The Emergency Door Module must attach in a series circuit with the start circuit (Fig. 3)

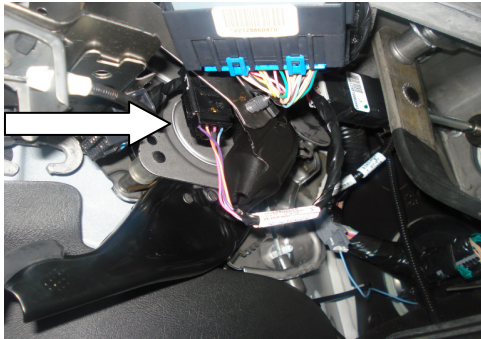

(Fig. 1)

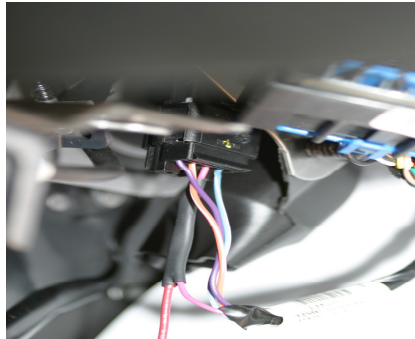

(Fig. 2)

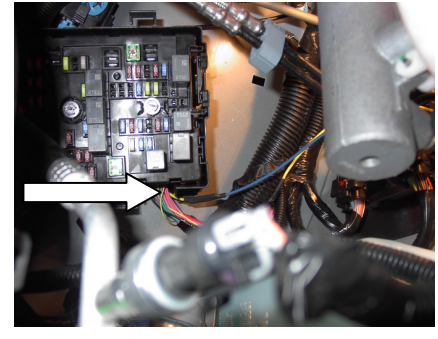

(Fig. 3)

EDM603-GD-B Module Mounting

1. Locate an area behind the lower dash panel to mount the EDM603-GD module. Do not block the opening in the module or the alarm volume will be reduced. The module can be mounted using supplied screws or double sided tape
2. Attach the Black wire to a known good ground point. Snap the 4-pin vehicle harness installed above into the module 4-pin connector. The Black 2 pin Weather-Pack connector will attach to the door circuits. NOTE: The mate to this connector is not included. The mating connector is Part # 12010973-B. The Terminals are Part # 12124582-L. The connector seals (optional) are part # 12015323-B.
3. Connect the White wire to the door open switch. This circuit must provide a ground when the door is open.
4. Connect the Green wire to the door lock switch. This circuit must provide a ground when the door is locked.

Reconnect vehicle battery.

GM/Chevy 610 – 2010-2016 4.3L, 4.8L, and 6.0L Engines

1. Locate the Engine Control Module (ECM) on the driver's side of engine compartment. (Fig. 1)
2. Locate the X1 connector on the ECM. The X1 connector will be Black on 4.3L, 4.8L, and 6.0L engines. (Fig. 2)
3. Remove the connector cover. Open the main wire harness and locate start circuit wire. On a 4.3L engine, it is the Pin #32 Yellow/Black wire. On 4.8L and 6.0L engines, it is the Pin #52 Yellow/Black wire. On a 2016 vehicle, it is the Pin #5 Yellow/Black wire. Cut the Yellow/Black wire 2" from the connector.
4. Run the EDM harness (Yellow and Blue) through the bulkhead using a grommet to prevent chafing.

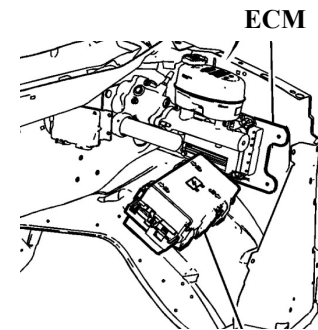

(Fig. 1)

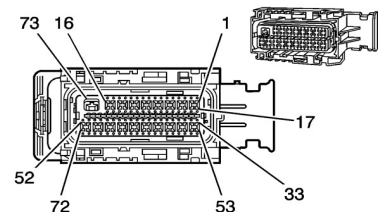

(Fig. 2)

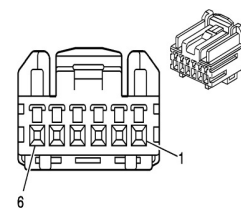

(Fig. 3)

Red Wire – Locate the Ignition Switch Connector under dash (Fig. 3). Attach the Red wire to the Pin #2 Pink wire in parallel to this circuit by stripping the insulation, soldering, and taping. **Note: Do not connect the Red wire to Pin #5, it is also a Pink wire.**

Yellow Wire – Attach the **female** 2-pin connector, pin #2 Yellow wire to the connector side of the Yellow/Black wire. Solder and heat shrink this connection.

Blue Wire – Attach the **male** 2-pin connector, pin #2 Blue wire to the harness side of the Yellow/Black wire. Solder and heat shrink this connection.

EDM603-GD-B Module Mounting

1. Locate an area behind the lower dash panel to mount the EDM603-GD module. Do not block the opening in the module or the alarm volume will be reduced. The module can be mounted using supplied screws or double sided tape
2. Attach the Black wire to a known good ground point. Snap the 4-pin vehicle harness installed above into the module 4-pin connector. The Black 2 pin Weather-Pack connector will attach to the door circuits. NOTE: The mate to this connector is not included. The mating connector is Part # 12010973-B. The Terminals are Part # 12124582-L. The connector seals (optional) are part # 12015323-B.
3. Connect the White wire to the door open switch. This circuit must provide a ground when the door is open.
4. Connect the Green wire to the door lock switch. This circuit must provide a ground when the door is locked.

Reconnect vehicle battery.

GM/Chevy 610 – 2010-2012

6.6L Diesel Engines

Disconnect vehicle battery. Locate the Engine Control Module (ECM) on the driver's side of engine compartment. (Fig. 1)

Locate the X1 connector on the ECM. The X1 connector will be Blue on 6.6L diesel engines. (Fig. 2)

Remove the connector cover. Open the main wire harness and locate the Pin #5 Yellow/Black start circuit wire. Cut the Yellow/Black wire 2" from the connector.

Run the EDM harness (Yellow and Blue) through the bulkhead using a grommet to prevent chafing.

Red Wire – Locate the Ignition Switch Connector under dash (Fig. 3). Attach the Red wire to the Pin #2 Pink wire in parallel to this circuit by stripping the insulation, soldering, and taping. **Note: Do not connect the Red wire to Pin #5, it is also a Pink wire.**

Yellow Wire – Attach the **female** 2-pin connector, pin #2 Yellow wire to the connector side of the Yellow/Black wire. Solder and heat shrink this connection.

Blue Wire – Attach the **male** 2-pin connector Pin #2 Blue wire to the harness side of the Yellow/Black wire. Solder and heat shrink this connection.

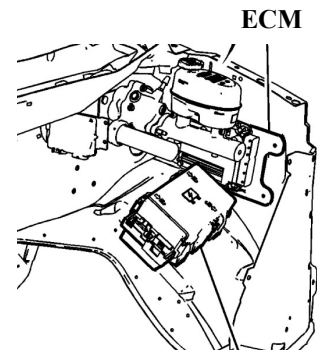

(Fig. 1)

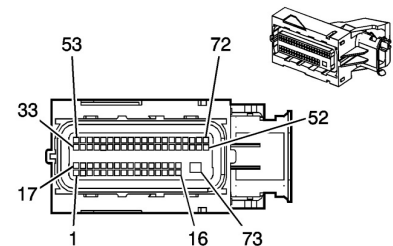

(Fig. 2)

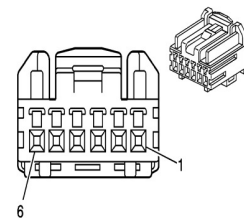

(Fig. 3)

EDM603-GD-B Module Mounting

1. Locate an area behind the lower dash panel to mount the EDM603-GD module. Do not block the opening in the module or the alarm volume will be reduced. The module can be mounted using supplied screws or double sided tape
2. **Attach the Black wire to a known good ground point.** Snap the 4-pin vehicle harness installed above into the module 4-pin connector. The Black 2 pin Weather-Pack connector will attach to the door circuits. **NOTE:** The mate to this connector is not included. The mating connector is Part # 12010973-B. The Terminals are Part # 12124582-L. The connector seals (optional) are part # 12015323-B.
3. Connect the White wire to the door open switch. This circuit must provide a ground when the door is open.
4. Connect the Green wire to the door lock switch. This circuit must provide a ground when the door is locked.

Reconnect vehicle battery.

Reconnect vehicle battery

Post Installation Test

1. Close the rear emergency door and do not lock. Verify the vehicle starts.
2. Close the rear emergency door and lock it. Verify the vehicle will not start and the warning alarm sounds.
3. Open the rear emergency door. Verify the vehicle will not start and the warning alarm sounds.

If the EDM6030GD0B fails any of the above tests, recheck all connections.. If necessary, call InterMotive Technical Support at (530) 823-1048

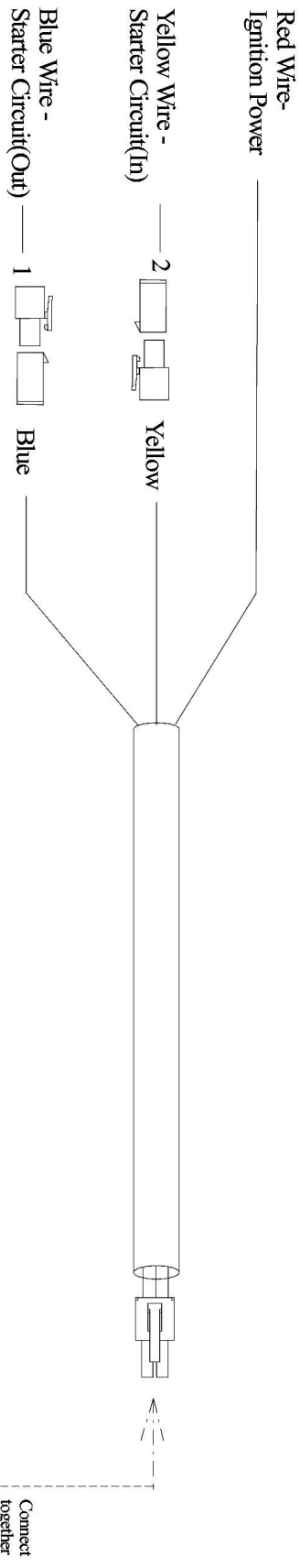

EDM Module

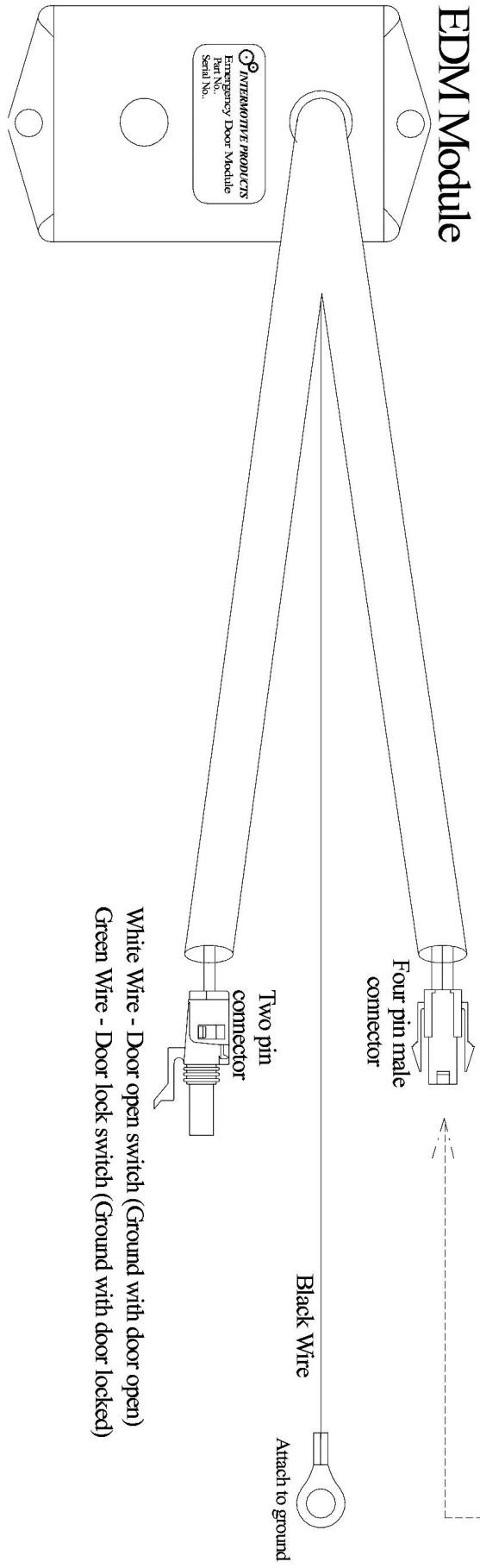

Submit product registration at www.intermotive.net

If the EDM603-GD fails any step in the Post Installation Test, review the installation instructions and check all connections. If necessary, call **InterMotive Technical Support at (530) 823-1048.**