

## **ECO950**

### **2014-2023 Isuzu NPR Gasoline Engine Only**

### **2019-2020 Chevy LCF (Low Cab Forward Trucks)**

Contact InterMotive for additional vehicle applications



#### **Introduction**

The ECO950 is an automatic engine stop/start system designed to enhance fuel economy, lower vehicle emissions, and allow an operator to remotely control engine stop/start. The engine is automatically stopped to prevent unnecessary idling. Restarts can be automatically triggered by low battery voltage, Service Brake application, or user restart requests. An optional thermistor may be attached to the Engine On input if a temperature triggered auto-restart is desired. A cab tilt switch input disables the system if the cab is tilted and auto-restarts are preceded by a warning beeper for safe system operation.

#### **Installation Instructions**

**Disconnect vehicle battery before proceeding with installation**



**WARNING**  
Disconnect the battery to  
prevent setting a check engine  
light.

#### **IMPORTANT—READ BEFORE INSTALLATION**

It is the installer's responsibility to route and secure all wiring harnesses where they cannot be damaged by sharp objects, mechanical moving parts and high heat sources. Failure to do so could result in damage to the system or vehicle and create possible safety concerns for the operator and passengers.

Avoid placing the modules where they could encounter strong magnetic fields from high current cabling connected to motors, solenoids, etc. Avoid radio frequency energy from antennas or inverters next to the module. Avoid high voltage spikes in vehicle wiring by always using diode clamped relays when installing upfitter circuits.

#### **ECO Module Installation**

Remove the lower dash panel below the steering column and find a suitable location to mount the module. Mount the module in an area away from any external heat sources (engine heat, heater ducts, etc.). Do not actually mount the module until all wire harnesses are routed and secure. The last step of the installation is to mount the module. When installing the harnesses, leave several inches of take-out such that the module can be removed if necessary.

## Data Link Harness

1. Locate the ECO950 data link harness in the kit. See picture. This will "T" into the vehicles OBDII connector.
2. Locate the vehicles OBDII Data Link Connector located below the lower left dash panel under the steering wheel area. See picture.
3. Remove OEM OBDII connector by pinching the sides and pushing it out the rear of the OEM bracket.
4. Install the white ECO950 data link harness OBDII connector into the OEM bracket by pushing it in from the rear.
5. Plug the red connector from the ECO950 data link harness into the vehicles OBDII connector. Ensure the connection is fully seated and secure with the supplied wire tie.
6. Secure the harness so that it does not hang below the lower dash panel.



OEM OBDII bracket with White ECO950 connector installed.

## ECO950 Ignition Switch Harness

This harness T's into the vehicles ignition switch.

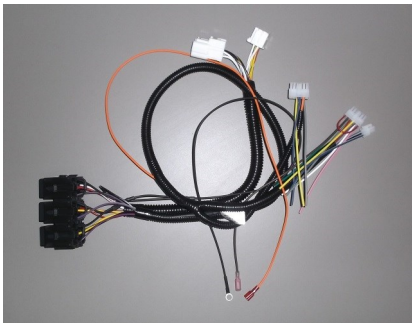

ECO950 Ignition switch harness

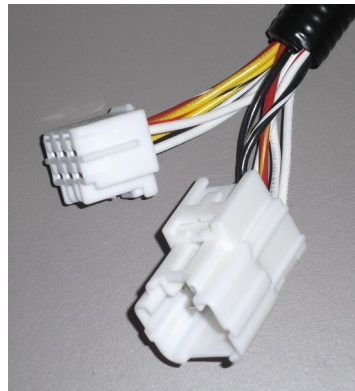

Ignition switch connectors mate with Isuzu switch and harness

## ECO950 Ignition Switch harness (cont.)

1. Remove the upper and lower steering column trim covers by removing three Torx screws from the bottom cover.
2. Locate the ignition switch connector and unplug it from the switch.
3. Install the ECO950 ignition switch harness between the Ignition Switch and the OEM harness.
4. Route the ECO950 harness down the steering column and secure with cable ties.
5. Plug the 12 Pin ECO connector into the ECO module.
6. There is a black wire with an eyelet which must be connected to chassis ground. Find an appropriate location and ground the harness eyelet with a screw.
7. There are two sections of the ignition switch harness. These are normally supplied already plugged together with their 4 pin in-line connectors, but allow installing these sections separately if desired.

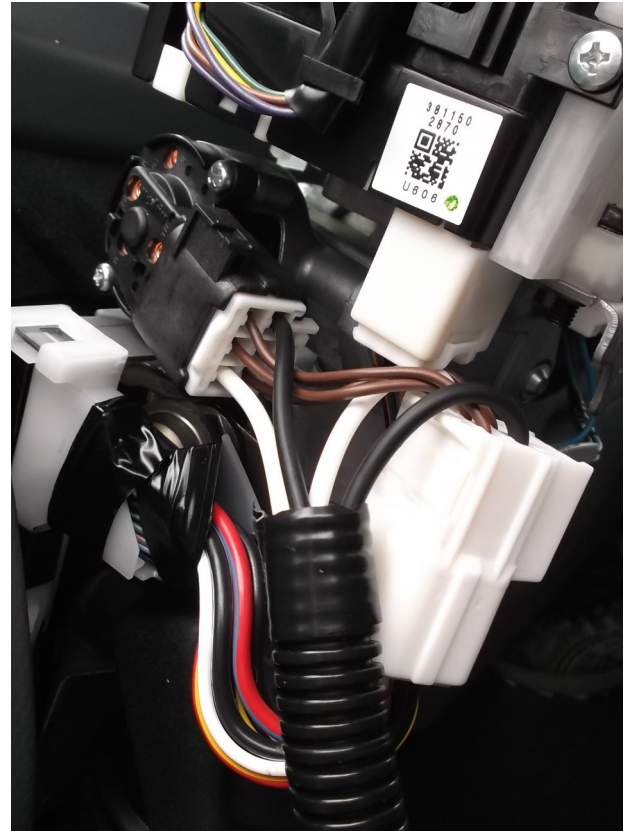

Back side of Isuzu ignition switch with ECO950 harness "T" installed between the switch and OEM harness.

## ECO I/O Features and Descriptions: (Solder and heat shrink all connections)

### Cab Tilt Disable Switch

The Cab Tilt Disable Switch is **NOT** an optional input. This grounding connection **MUST** be made in order for the module to operate. It is one of the most important safety features and time must be taken to properly install the switch such that a ground contact is made only with the cab locked in downward position.

Pin #11 (Brown wire) of the 12 pin connector is the Cab Tilt Disable input. The absence of a ground signal when the cab is tilted prevents auto engine start/stop. As an important safety feature, this connection must be made to prevent auto-restarting when someone is working on the engine with the cab tilted forward.

## ECO I/O Features and Descriptions: (continued) (Solder and heat shrink all connections)

### Cab Tilt Disable Switch (continued)

The proximity sensor provided in the ECO950 kit will provide the signal to the module when the cab is in the upright position. The sensor is made up of a magnet (no wires attached) and the magnetic switch (black and brown wires attached). The magnet will be installed on the cab tilt locking arm. The magnetic switch will be installed on the frame rail where the magnet will come into close proximity.

With the cab in the upright and locked position, mark where the locking arm lines up with the frame rail. Choose an appropriate location on the locking arm to mount the magnet. Drill two 4.40mm (11/64") holes on the arm aligned with magnet holes. Secure magnet to arm with supplied self tapping screws. Mount the switch in the same fashion on the frame rail directly across from the magnet (with the cab in upright and locked position). Route switch wires into cab. Ground the eyelet attached to the black wire. Attach male bullet connector to female bullet connector on brown wire from module.



Ground located inside cab, driver's side left kick panel



Locking arm (upper left) and frame rail (lower right)

### Engine Off Request Input

Pin #2 (White wire) of the 12 Pin Connector is an Engine Off Request input. Grounding this wire with a switch allows remote engine shutoff capability. Keeping this input grounded will keep the ignition switch power off (exceptions: a remote Engine Restart request OR a low battery **will** restore ignition power and restart the engine). Leaving the ignition off after an Engine Off request reduces the draw on the battery to a minimum, allowing the greatest amount of time between low battery restarts.

### Engine On Request Input

Pin #5 (Green wire) of the 12 Pin Connector is the Engine On Request input which may be wired to vehicle equipment which requires the engine to continue running. **This switch input must provide a ground when restart is desired.** Solder and heat shrink all connections. This input also acts as a Shutdown Inhibit. As long as it is active (grounded), the Anti-Idle shutdown timer and the Request Engine/Ignition Off inputs will not turn the vehicle off.

An optional thermistor may be attached to the Engine On input if a temperature activated auto-restart is desired. The thermistor option may be used to auto restart the engine as a result of either cold or hot temperatures. For example, it may be used to prevent the engine from getting too cold in severe environments. Mount the thermistor in a location where it cannot be damaged by sharp objects and mechanical moving parts such as the Park Brake or tilt steering wheel mechanisms.

- **Low Temperature Thermostat Engine Cycling** Assumes the cabin heater is turned on. If the cabin temperature does not increase 3 degrees in 6 minutes after a low temperature restart the thermostat is disabled until the key is cycled.
- **High Temperature Thermostat Engine Cycling** Assumes the cabin air conditioner is turned On. If the cabin temperature does not decrease 3 degrees in 6 minutes after a high temperature restart, the thermostat is disabled until the key is cycled.



## ECO I/O Features and Descriptions (continued)

### Security Input

Pin #1 of the 4 Pin Connector is an optional security input. When this input is grounded by a switch, the engine will auto shut off if the Transmission is shifted out of Park. A hidden keyed switch could be used for added security. Connect one of the provided Molex pins to an installer supplied wire and insert into cavity 1 of the 4 pin Molex header. Connect free end of wire to installer provided switch.

### Aux Battery Input (Up to 36 Volt)

Pin #4 (Gray wire) of the 12 Pin Connector is an auxiliary battery voltage monitor input. It measures the analog battery input and can trigger a low battery restart when this input falls below a user defined level. By default this trigger is disabled, but it may be enabled via a laptop connection. Contact InterMotive for details or refer to Eco-Star Application Note.

### Restart Beeper

Pin #3 (Orange wire) of the 12 Pin Connector drives a warning beeper that will sound for 2 seconds prior to all restarts except Service Brake restarts. The beeper is shared with EMS950.

### Un-Interrupted Load Control

Eco-Star shuts down the vehicle's engine by simulating a "key off" condition. All electrical loads that normally shut off when the key is turned off will lose power as long as the Engine Off Request is active. This may not be desirable for all loads and can be avoided by wiring an external relay to Eco-Star's Ignition Power Signal Pin #9 Yellow wire (1 Amp max, see below).

The Ignition Power Signal will normally activate only when the key is in the Run/Start position. However, when Eco-Star is commanding Ignition Off, the Ignition Power Signal becomes Key In Ignition. These loads will drain the battery faster. Use of LED lights and higher capacity batteries is recommended.

### Equipment Enable Output

The equipment enable output will force the user to depend on Eco-Star stop/start capability in order to use their equipment. This load is only active when the Request Engine Off input is active. While this input is active, Eco-Star will cycle the engine based on primary/secondary battery Voltages and the Request Engine On input (which now includes the optional thermostat function).

The Equipment Enable Load Output is similar to the Un-Interrupted Load Output. The difference is that this load ensures that Eco-Star is cycling the engine. In the case of the Un-Interrupted Load Output, there are ways to disable the stop/start capabilities of Eco-Star (disable idle timer or set to 30 minute idle time) while retaining the output.

The Pin #9 (Yellow wire) and Pin #1 (Pink Wire) outputs are capable of driving up to 1 Amp max. When connecting to a relay, always use a diode clamped relay, such as Digikey part number PB682-ND, or add a diode across the relay coil as shown, observing the required polarity. The use of a relay without diode clamped suppression causes high voltage spikes when the relay coil is deactivated. These voltage spikes may cause damage or intermittent behavior to on-board vehicle control modules. Resistors and other methods of clamping are not as effective and are not recommended.

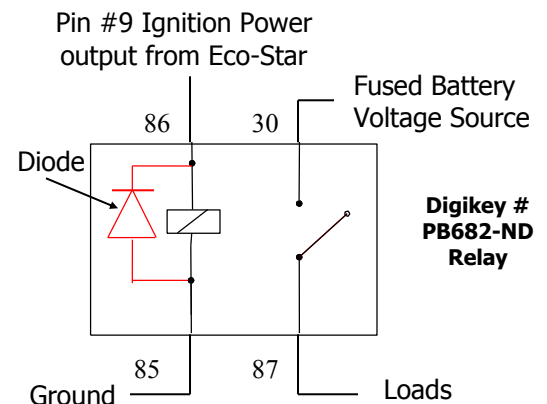

## Post Installation Testing

### ECO Testing: (module must be visible for this test)

Several conditions will prevent Eco-Star from auto-shutdown in test mode: Trans Range Not in Park, Service Brake Pedal Applied, Cab tilted, Vehicle Speed not 0, or Engine Start Request Active.

1. With key in the run position and engine off, apply ground to the gold circle on the module labeled "TEST". The status LED will start blinking; Eco-Star is now in test mode. In test mode the system functions without monitoring these pre-conditions: Engine Temp, Battery Voltage, or Ambient Air Temp.
2. Start the engine with transmission in Park and Cab locked in downward position.
3. Activate Engine Off Request input. Verify engine shuts off and ignition power is off (simulates key off).
4. Release Engine Off Request input. Verify ignition power is restored. Engine will not start (low battery could cause a restart).
5. Activate the Engine On Request input. The Engine will automatically restart.
6. Release the Engine On Request input and confirm the module shuts off the engine after the idle timer has expired (default 15 seconds). **Note:** Applying the Service Brake will prevent the timer from counting down and shutting off the engine.
7. Repeat step 4 with cab tilted forward. As a safety feature, the system must not start or stop the engine when the cab is tilted. If the Engine Start Request starts engine with cab tilted, check cab tilt switch wiring.

**Do not put vehicle in service unless cab tilt switch prevents Eco-Star from starting engine.**

**The ECO950 system is properly installed only if it passes all of the above steps. If any irregular operation is observed, contact InterMotive at 530-823-1048 for technical assistance.**

### Final assembly

Ensure all harnesses are properly routed, and are not hanging below the dash area. Reinstall the steering column trim cover and under dash panel. Installation is complete.

# Appendix A

## Tera Term Setup

1. A special Serial Communication Cable is available from Intermotive to use this method. You will be required to download and install the proper USB driver the first time you use this cable. All driver files are located online at: <http://www.intermotive.net>
2. Find the correct drivers for your system and follow the steps to download the latest version (located under the "Driver Version" heading). If unsure about the installation process, contact InterMotive for assistance.
3. Download and install the latest release of the Tera Term application from: <http://www.intermotive.net>
4. Plug one end of the cable into your PC's USB port, and with the vehicle's key in the off position, plug the other end into the module's COM port.
5. Open the Tera Term application. The Tera Term 'New Connection' window will open (see picture).
6. Click the 'Serial' button and choose the COM Port that the Intermotive Download Cable is connected to (typically the highest numbered COM Port). Click 'OK'.
7. Under the 'Setup' tab, choose 'Serial Port'.
8. In the next window, you will need to change several of the default parameters for the Port Settings as follows:
  - Baud rate: 57600
  - Data: 8 bits
  - Parity: None
  - Flow Control: None
  - Transmit delay: 0 msec/char 0 msec/line
  - Click 'OK'.
9. Tera Term setup is now complete.

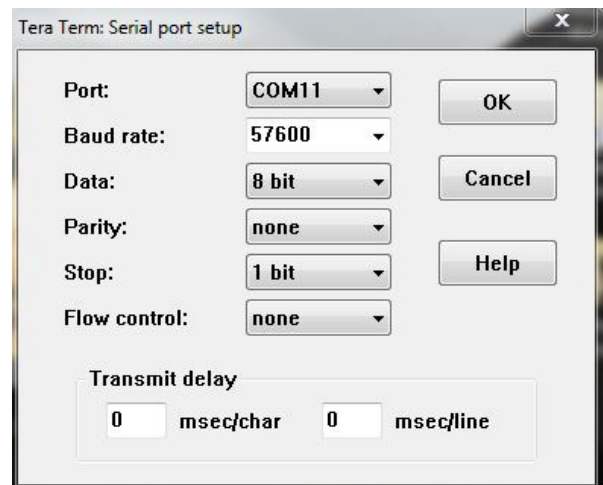
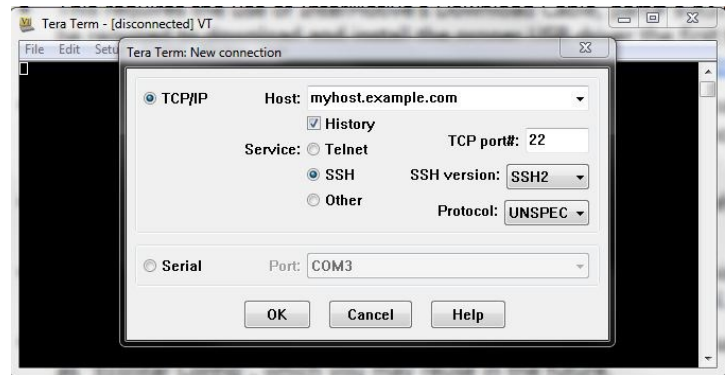

## Appendix A (cont.)

### Reconfiguring Eco-Star Parameters: (optional)

#### Requirements

- USB to Serial Communication cable (Intermotive part number S-H37A1) which is a one time purchase. This is required for all programming.
- Laptop computer (programming is done while the module is on the vehicle).

#### Reconfiguring

1. Complete **Tera Term Setup** on the first page of Appendix A.
2. Turn the vehicle key to the ON position. The ECO950 module will wakeup and text will be displayed on the open Tera Term window.
3. If nothing appears, unplug the 6 pin Data Link connector going into the ECO950 module, wait several seconds, and plug the connector back in.
4. If still nothing appears, go to File > New Connection and try re-configuring the HyperTerminal as described above. If unsuccessful, contact InterMotive for further assistance.
5. With communication established, type in the word "config" (followed by the enter key) and the screen will look like Screen Shot 1.
6. Type the number of the parameter to be changed followed by the enter key. Follow prompts to change selected parameter.
7. Press escape when parameters are set correctly.
8. When finished, key off ignition and disconnect the Communication cable.
9. See Eco-Star App Note for more Eco-Star configuration details.

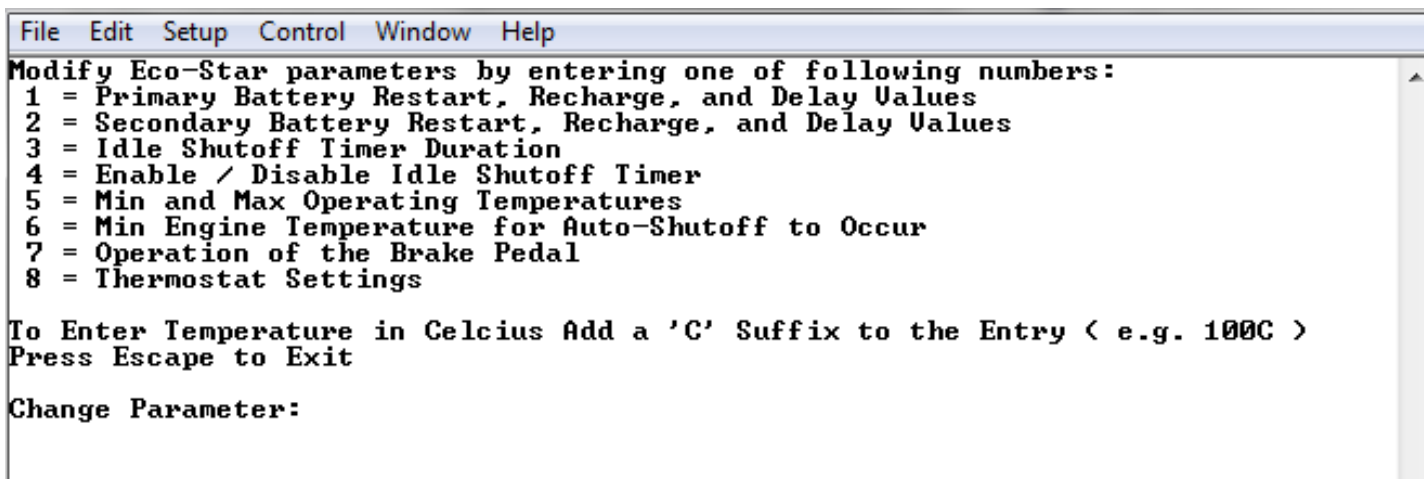
A screenshot of a terminal window with a menu bar containing 'File', 'Edit', 'Setup', 'Control', 'Window', and 'Help'. The terminal text reads: 'Modify Eco-Star parameters by entering one of following numbers: 1 = Primary Battery Restart, Recharge, and Delay Values; 2 = Secondary Battery Restart, Recharge, and Delay Values; 3 = Idle Shutoff Timer Duration; 4 = Enable / Disable Idle Shutoff Timer; 5 = Min and Max Operating Temperatures; 6 = Min Engine Temperature for Auto-Shutoff to Occur; 7 = Operation of the Brake Pedal; 8 = Thermostat Settings'. Below this, it says 'To Enter Temperature in Celcius Add a 'C' Suffix to the Entry < e.g. 100C >' and 'Press Escape to Exit'. At the bottom, it prompts 'Change Parameter:' followed by a vertical cursor line.

```
File Edit Setup Control Window Help
Modify Eco-Star parameters by entering one of following numbers:
1 = Primary Battery Restart, Recharge, and Delay Values
2 = Secondary Battery Restart, Recharge, and Delay Values
3 = Idle Shutoff Timer Duration
4 = Enable / Disable Idle Shutoff Timer
5 = Min and Max Operating Temperatures
6 = Min Engine Temperature for Auto-Shutoff to Occur
7 = Operation of the Brake Pedal
8 = Thermostat Settings

To Enter Temperature in Celcius Add a 'C' Suffix to the Entry < e.g. 100C >
Press Escape to Exit

Change Parameter:
|
```

Screen Shot 1





An ISO 9001:2015 Registered Company

## **Leave in vehicle Operating Instructions ECO950 Eco-Star**

### **System Overview**

The ECO950 automatically shuts off the engine if the vehicle is left idling for an extended period of time with no operator input. The system will then cycle the engine based on various parameters.

### **Eco-Star (ECO) Operation**

Eco-Star provides enhanced fuel economy and lower vehicle emissions for customers by limiting engine idle time. Restarts can be automatically triggered by low battery voltage, remote equipment operator requests or thermostat restart trigger (if enabled).

The Engine will be auto-stopped when the idle timer expires. The default timeout period is 15 seconds of idling in Park. Note that the Service Brake and the Engine On switch will prevent idle timer shutoff.

Once the engine has been auto-stopped, Eco-Star monitors the main battery voltage (an auxiliary battery may also be monitored). If either fall below a minimum restart voltage, the module will sound an alarm for 2 seconds and auto-restart the engine to recharge the batteries. The default restart value is 12.0 Volts for the main battery (aux battery input is disabled). Once the main battery charges above 13.5 volts, a recharge timer of 60 seconds begins that will turn off the engine again.

The Engine Off Request is an optional remote switch that when activated turns the engine off by switching off ignition power. The ignition remains off until: 1) Engine Off Request is removed or 2) an engine auto-restart is triggered. The module keeps ignition off to reduce current draw and delay a low battery restart.

The Engine On Request switch is an optional remote trigger that will start the engine and prevent all auto-stops from occurring. If the vehicle is equipped with the optional thermistor, the vehicle may also auto-restart based on temperature.

If a security switch has been installed and is "on", the engine will be turned off if the transmission is shifted out of Park. This is designed to prevent theft and/or unauthorized driving.

### **Default requirements for auto engine shut off**

Transmission in Park (vehicle not moving), Cab locked in downward position, Service Brake not applied, Battery Voltage greater than 12.0 Volts (may differ from default setting), no thermostat trigger, and Engine Restart switch must not be "on" (this switch input overrides the Engine Off Request and Idle Timer).

Note: The module will not respond to an Engine Off Requests for 5 seconds after the engine is started.

### **Default requirements for auto engine restart**

Cab locked in downward position, Engine must have been auto-stopped, Transmission in Park, and the key in the Run position.

Once above conditions are met, the engine will restart when the Engine On Request is activated, a low battery is detected or Thermostat restart trigger.

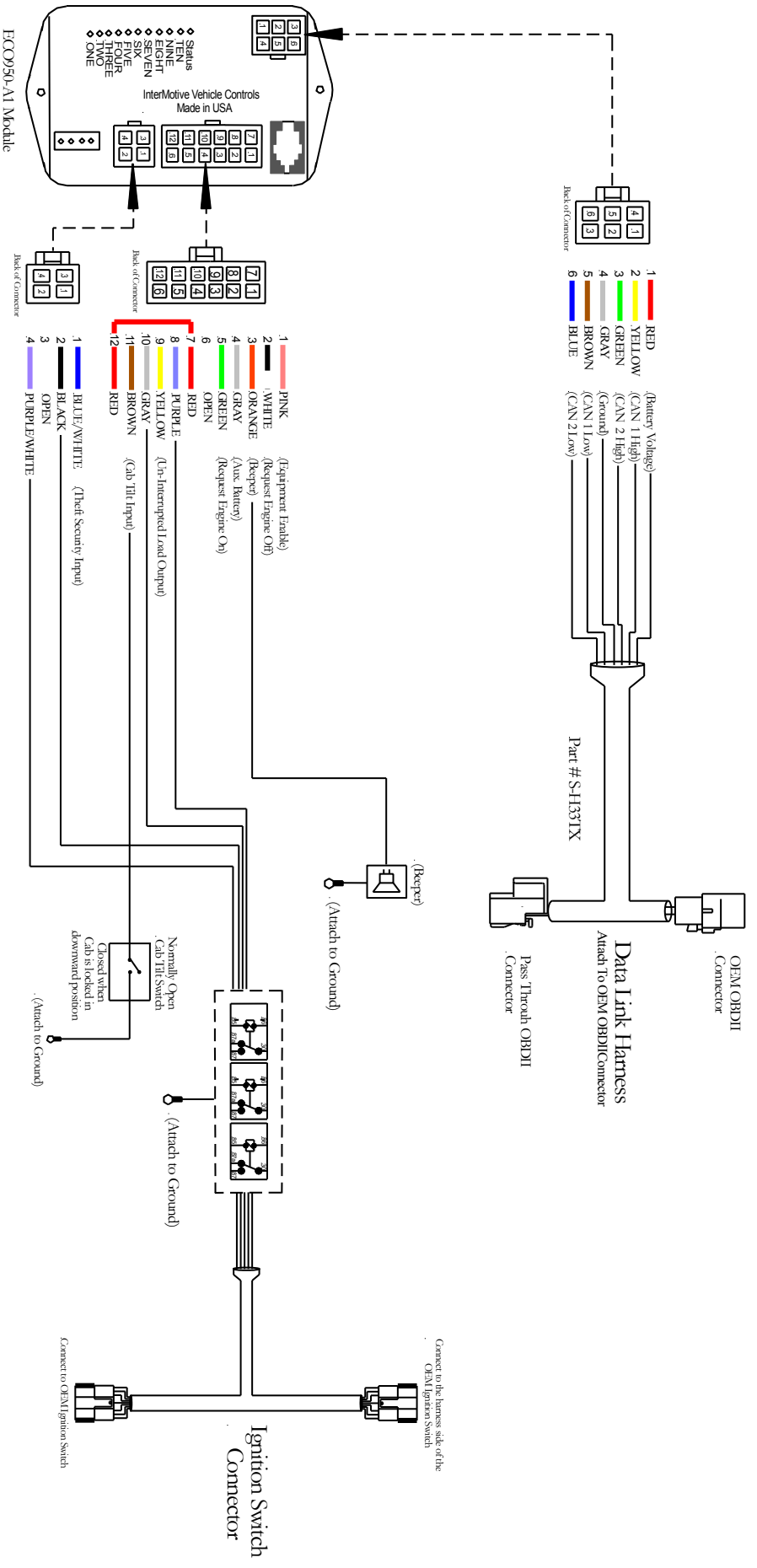

If the ECO950 fails any step in the Post Installation Check List, review the installation instructions and check all connections.  
 If necessary, call InterMotive Technical Support at (530) 823-1048.

**Submit product registration at [www.intermotive.net](http://www.intermotive.net)**