

Eco-Star model ECO507-CW (Work Truck Applications)
2011-2014 Ford F150
2011-2016 Ford F250-F600
2015-2017 Ford F150 (*B-ECO507-CW)
2017-2022 Ford F250-F600 (*B-ECO507-CW)
2021-2022 Ford E-Series (*B-ECO507-CW)
2022 F650-F750 (*B-ECO507-CW)



***Uses the Ford 24-Pin Data Link Harness**

Introduction

The Eco-Star ECO507-CW is an automatic engine stop/start system that provides enhanced fuel economy, lower vehicle emissions, and allows an operator to remotely control engine stop/start. Vehicle fuel economy is improved by automatically shutting off the vehicle's engine to prevent unnecessary idling. Restarts can be automatically triggered by low battery voltage, applying the Service Brake or user restart requests. With the battery charge protect feature, auto restarts can prevent a dead battery situation. Two separate battery system inputs allow auto restarts from either battery source. Additionally, a user has the ability to request the ignition to remain off after a shutdown, thus minimizing the draw on the battery and further reducing engine idle time. A hood switch interlock input disables the system when the hood is open. Auto restarts are preceded by a warning beeper sound.

If a temperature activated auto-restart is desired, an optional thermistor may be attached to the Engine On input. Instructions for this option can be found in the Eco-Star App Notes found at www.intermotive.net.

The following are the default vehicle safety and conditions for Auto Stop and Auto Restart. These and other parameters may be altered to suit specific needs, using a laptop and InterMotive communication cable. (See ECO-App Note).

Auto Stop Defaults	Auto Restart Defaults
Battery Voltages > 11.8 V	Vehicle Hood = Closed
Trans Range = Park or Neutral (speed = 0)	Trans Range = Park or Neutral (Speed = 0)
Engine On Request = Not Active	Engine Auto-Stopped by ECO507-CW
Brake Pedal = Not Pressed	Ignition Key in Run Position
Vehicle Hood = Closed	

When all Auto Stop Defaults are met, the ECO507-CW will automatically stop the engine. The engine will shut off when the idle timer expires or an external discrete wire Ignition Off Request is activated. The default idle timer is set to 15 seconds.

Engine restart is initiated automatically by a low battery voltage, or the application of a user restart input. There are two separate battery sources that can be configured to trigger a battery charge protect restart. By default, the restart voltage is set to 11.8 Volts for the main battery with a recharge period of at least 60 seconds. The secondary battery input is turned off by default, though it is capable of monitoring up to a 48 Volt input.

ECO507 Add-On Options

ECO507-CW-T: Thermistor for temperature activated Auto Restart

ECO507-CW-B: Hood Switch to allow Auto Restart only when hood is closed

Installation Instructions

Disconnect vehicle battery before proceeding with the installation.



WARNING
Disconnect the battery to
prevent setting a check engine
light.

IMPORTANT—READ BEFORE INSTALLATION

It is the installer's responsibility to route and secure all wiring harnesses where they cannot be damaged by sharp objects, mechanical moving parts and high heat sources. Failure to do so could result in damage to the system or vehicle and create possible safety concerns for the operator and passengers. Avoid placing the module where it could encounter strong magnetic fields from high current cabling connected to motors, solenoids, etc. Avoid radio frequency energy from antennas or inverters next to the module. Avoid high voltage spikes in vehicle wiring by always using diode clamped relays when installing upfitter circuits.

ECO507-CW Module

Remove the lower dash panel below the steering column and find a suitable location to mount the module. Locate the module in an area away from excessive heat sources (engine, heater ducts, etc.). Ensure when routing harnesses that the tilt steering column does not contact them in the full down position. When installing the harnesses, leave several inches of take-out so the module can be removed if necessary. Do not mount module until all wire harnesses are routed and secure. The last step of the installation is to mount the module.

Data Link Harness (6-pin connector)

1. Locate the vehicle's OBDII Data Link Connector, mounted below the lower left dash panel.
2. Remove the mounting screws for the OBDII connector. Plug the Red connector from the ECO507-CW Data Link Harness into the vehicle's OBDII connector. Ensure the connection is fully seated and secure with the supplied wire tie.
3. Mount the Black pass through connector from the ECO507-CW Data Link Harness in the former location of the vehicle's OBDII connector.
4. Secure the ECO507-CW Data Link harness so that it does not hang below the lower dash panel.
5. Plug the free end of the Data Link harness into the mating 6-pin connector on the ECO507-CW module.

**Data
Link
Harness
plugs in
here**



Installation Instructions (Continued)

Ford 24-pin Data Link Harness (6-pin connector)

1. Locate the vehicles Gateway Module. It will be mounted below the lower left dash panel.
2. Remove the harness behind the Gateway module by pressing the locking tab and pulling outward.
3. Plug the Female side of the Intermotive Gateway Harness into the back of the Gateway module. Ensure the connection is fully seated and secured by the locking tab.
4. Plug the Male side of the Intermotive Data Link Harness into the Gateway harness.
5. Secure the PRPC Gateway harness so that it does not hang below the lower dash panel.

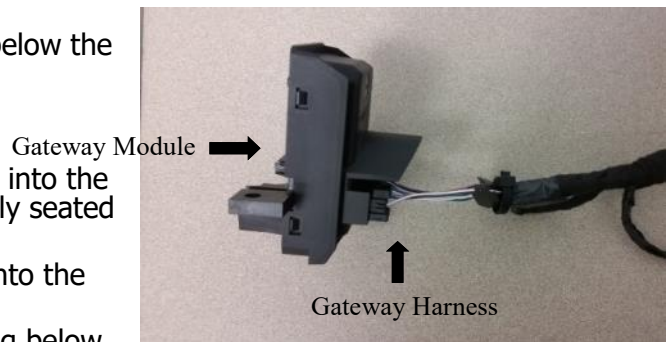

Ignition Switch Connections

1. Remove the lower steering column trim cover. Locate the ignition switch connector (C250) and disconnect it from the ignition switch.
2. Install the ECO507-CW harness between the Ignition Switch and the OEM connector.
3. Plug the ECO507-CW 12-Pin connector into the mating 12-Pin connector on the ECO507-CW module.
4. Plug the ECO507-CW 4-Pin connector into the mating 4-Pin connector on the ECO507-CW module.

**F Series
C250
Front of
Connector**

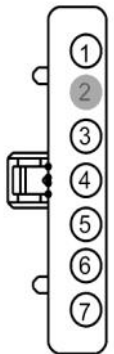

Installation Instructions (continued)

I/O Features and Descriptions: (Solder and heat shrink all connections)

Hood Open Disable Switch

The Hood Open Disable Switch is **not** an optional input. This grounding connection **must** be made in order for the module to operate. It is one of the most important safety features and the time must be taken to properly install a switch such that a ground contact is made only with the hood fully closed .

Pin #3 (Brown wire) of the 4 pin connector is the Hood Open Disable input. As an important safety feature, this connection must be made to prevent auto restarting when someone is working under the hood area. Extend the Brown Hood Open Disable wire through the bulkhead into the engine compartment (solder and heat shrink all connections). Attach the Hood Open Disable wire to a normally open hood switch that grounds this signal when the hood is closed. A low current switch with gold contacts is recommended.

Engine Off Request Input

Pin #2 (White wire) of the 12 Pin Connector is an Engine Off Request input. Grounding this wire with a switch allows remote engine shutoff capability. Keeping this input grounded will keep the ignition switch power off (exceptions: a remote Engine Restart request OR a low battery **will** restore ignition power and restart the engine). Leaving the ignition off after an Engine Off request reduces the draw on the battery to a minimum, allowing the greatest amount of time between low battery restarts.

Engine On Request Input

Pin #5 (Green wire) of the 12 Pin Connector is the Engine On Request input which may be wired to vehicle equipment which requires the engine to continue running. **This switch input must provide a ground when restart is desired.** Solder and heat shrink all connections. This input also acts as a Shutdown Inhibit. As long as it is active (grounded), the Anti-Idle shutdown timer and the Request Engine/Ignition Off inputs will not turn the vehicle off.

An optional thermistor may be attached to the Engine On input if a temperature activated auto-restart is desired. The thermistor option may be used to auto restart the engine as a result of either cold or hot temperatures. For example, it may be used to prevent the engine from getting too cold in severe environments. It may also be used in police K9 vehicles to prevent cabin temperature extremes. Mount the thermistor in a location where it cannot be damaged by sharp objects and mechanical moving parts such as the Park Brake or tilt steering wheel mechanisms.

- **Low Temperature Thermostat Engine Cycling** Assumes the cabin heater is turned on. If the cabin temperature does not increase 3 degrees in 6 minutes after a low temperature restart the thermostat is disabled until the key is cycled.
- **High Temperature Thermostat Engine Cycling** Assumes the cabin air conditioner is turned On. If the cabin temperature does not decrease 3 degrees in 6 minutes after a high temperature restart, the thermostat is disabled until the key is cycled.

Security Input

Pin #1 of the 4 Pin Connector is an optional security input. When this input is grounded by a switch, the engine will auto shut off if the Transmission is shifted out of Park. A hidden keyed switch could be used for added security. Connect one of the provided Molex pins to an installer supplied wire and insert into cavity 1 of the 4 pin Molex header. Connect free end of wire to installer provided switch.

- Instructions for this option can be found in the Eco-Star App Note found at www.intermotive.net

I/O Features and Descriptions (continued)

Aux Battery Input

(Up to 48 Volts if build number is labeled as 30-518 on White box on circuit board. Up to 36 Volts if labeled anything other than 30-518 in White box).



Pin #4 (Gray wire) of the 12 Pin Connector is an auxiliary battery voltage monitor input. It measures the analog battery input and can trigger a low battery restart when this input falls below a user defined level. By default this trigger is disabled, but it may be enabled via a laptop connection. Contact InterMotive for details or refer to Eco-Start Application Note. A spare Molex pin is provided in the kit to allow the use of this input.

Restart Beeper

Pin #3 (Orange wire) of the 12 Pin Connector drives a warning beeper that will sound for 2 seconds prior to all restarts except Service Brake restarts.

1. Find a suitable location for mounting the warning beeper so that it is audible to the driver.
2. Connect Orange lead to Red post of beeper and Black lead to the negative post. The Black lead eyelet must be grounded in order for the beeper to function.

The bezel on the beeper can be rotated to control volume.

Un-Interrupted Load Control

ECO507-CW shuts down the vehicle's engine by simulating a "key off" condition. All electrical loads that normally shut off when the key is turned off will lose power as long as the Engine Off Request is active. This may not be desirable for all loads and can be avoided by wiring an external relay to Eco-Star's Ignition Power Signal Pin #9 Yellow wire (1 Amp max, see below).

The Ignition Power Signal will normally activate only when the key is in the Run/Start position. However, when Eco-Star is commanding Ignition Off, the Ignition Power Signal becomes Key In Ignition. These loads will drain the battery faster. Use of LED lights and higher capacity batteries is recommended.

Equipment Enable Output

The equipment enable output will force the user to depend on Eco-Star stop/start capability in order to use their equipment. This load is only active when the Request Engine Off input is active. While this input is active, Eco-Star will cycle the engine based on primary/secondary battery Voltages and the Request Engine On input (which now includes the optional thermostat function).

The Equipment Enable Load Output is similar to the Un-Interrupted Load Output. The difference is that this load ensures that Eco-Star is cycling the engine. In the case of the Un-Interrupted Load Output, there are ways to disable the stop/start capabilities of Eco-Star (disable idle timer or set to 30 minute idle time) while retaining the output.

The Pin #9 (Yellow wire) and Pin #1 (Pink Wire) outputs are capable of driving up to 1 Amp max. When connecting to a relay, always use a diode clamped relay, such as Digikey part number PB682-ND, or add a diode across the relay coil as shown, observing the required polarity. The use of a relay without diode clamped suppression causes high voltage spikes when the relay coil is deactivated. These voltage spikes may cause damage or intermittent behavior to on-board vehicle control modules. Resistors and other methods of clamping are not as effective and are not recommended.

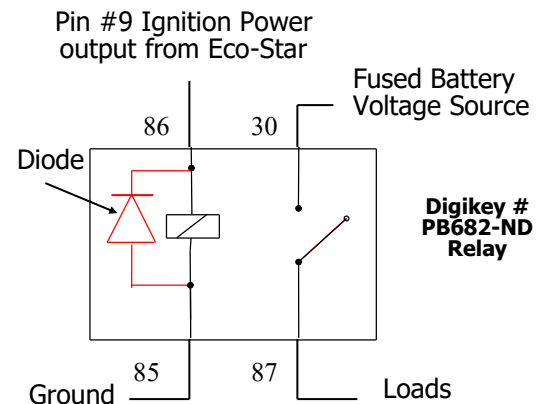

ECO507 Module Mounting

Ensure all harnesses are properly connected and routed and are not hanging below the dash area. Mount the module as described on page one, and secure with two screws or double sided tape.

Reconnect vehicle battery

Post Installation Operational Test

Setting module into Installation Test Mode

The installation test mode can be entered by applying a ground to the silver pad on the module labeled "TEST". When test mode activates, the status LED will start blinking; the ECO507-CW now functions without monitoring the following pre-conditions: Engine Temp, Battery Voltage, or Ambient Air Temp. This allows for easier testing for the installer.

Several conditions will prevent ECO507-CW from auto-shutdown in test mode:

Trans Range Not in Park or Neutral, Service Brake Pedal Applied, Hood Open (Open = Not Grounded), Vehicle Speed not 0, or Engine Start Request Active (Grounded).

Test 1. With engine running, transmission in Park or Neutral, hood closed, activate the Engine Off Request switch input. Engine will shut off, ignition will go off and stay off (acts like key off).

Test 2. Release the Engine Off Request. Ignition power will be restored, loads that are powered with key in Run will be restored. Engine will not start (low battery could cause a restart).

Test 3. Activate the Engine Start Request. The Engine will automatically restart.

Test 4. Release the Engine Start Request and confirm the module shuts off the engine after 15 seconds. Note: Applying the Service Brake will prevent the timer from counting down and shutting off the engine.

Test 5. Repeat test 3 with hood open. As a safety feature, the ECO507-CW MUST NOT start or stop the engine when the hood is open. If the Engine Start Request starts engine with hood open, check hood switch wiring.

NOTE: ECO507-CW will not shut off the engine for 5 seconds after the engine is started.

Do not put vehicle in service unless hood open disables Eco-Star from auto restarting engine.

If the system fails any of the above tests, check the related wiring. If necessary, call InterMotive Technical Support. Do NOT release vehicle for service unless it has passed all of the above tests.

Want to change default settings?

To make changes to the default Eco-Star configuration, see InterMotive Application Note for the ECO507 on our website (www.intermotive.net). This document goes into greater detail on the parameters and safety conditions of Eco-Star. If the configuration is altered, make note of the modifications for future serviceability and include them with the vehicle.



An ISO 9001:2015 Registered Company

Leave in vehicle

Operating Instructions ECO Star model ECO507-CW

2011-2014 Ford F150
2011-2016 Ford F250-F600
2015-2017 Ford F150 (B-ECO507-CW)
2017-2022 Ford F250-F600 (B-ECO507-CW)
2021-2022 Ford E-Series (B-ECO507-CW)
2022 F650-F750 (B-ECO507-CW)

- The ECO507-CW provides enhanced fuel economy and lower vehicle emissions for customers by limiting engine idle time. Vehicle fuel economy is improved by automatically shutting off the vehicle's engine to prevent unnecessary idling. Restarts can be automatically triggered by low battery voltage, remote equipment operator requests or thermostat restart trigger (if enabled).
- The Engine Off Request is a remote switch that when activated turns the engine off by switching off ignition power. The ignition remains off until: 1) Engine Off Request is removed, 2) Low battery causes a restart, 3) a remote Engine Start Request switch is activated or 4) Thermostat triggered restart. The module keeps ignition off to reduce the demand on the batteries, thereby delaying a low battery restart as long as possible.
- The Engine will also be auto-stopped when the idle time exceeds the time out period. The default timeout period is 15 seconds of idling in Park or Neutral. After that period elapses, the engine will be automatically turned off. Note that the Service Brake and the Engine On switch will prevent idle timer shutoff.
- The Engine On Request switch, if installed, is a remote trigger that, when activated, will start the engine after an auto-stop has occurred. Activating the Engine On Request while the vehicle is running will prevent all auto-stops from occurring. If the vehicle is equipped with the optional thermistor, the vehicle may auto-restart and shut off based on temperature
- Once the engine has been auto-stopped, ECO507-CW monitors the main battery voltage (an auxiliary battery may also be monitored). If either fall below a minimum restart voltage, the module will sound an alarm for 2 seconds and auto-restart the vehicle to recharge the batteries. The default restart value is 11.8 Volts for the main battery (aux battery input is disabled). Once the main battery charges above 13.5 volts, a recharge timer of 60 seconds begins that will turn off the engine again.
- If a security switch has been installed and is "on", the engine will be turned off if the transmission is shifted out of Park. This can prevent theft and/or unauthorized driving.

Default requirements for auto engine shut off

Transmission in Park or Neutral (vehicle not moving), Hood Closed, Service Brake not applied, Battery Voltage greater than 11.8 Volts (may differ from default setting), no thermostat trigger, and Engine Restart switch must not be "on" (this switch input overrides the Engine Off Request and Idle Timer).

Note: The module will not respond to an Engine Off Request for 5 seconds after the engine is started.

Default requirements for auto engine restart

Hood Closed, Engine must have been auto-stopped, Transmission in Park or Neutral, and the key in the Run position.

Once above conditions are met, the engine will restart when the Engine On Request is activated, a low battery is detected or Thermostat restart trigger.

The ECO507-CW may be removed from the vehicle by unplugging the ECO507-CW 6 pin harness (behind lower drivers dash panel) and restoring the OEM ignition switch wiring (under steering column trim cover).

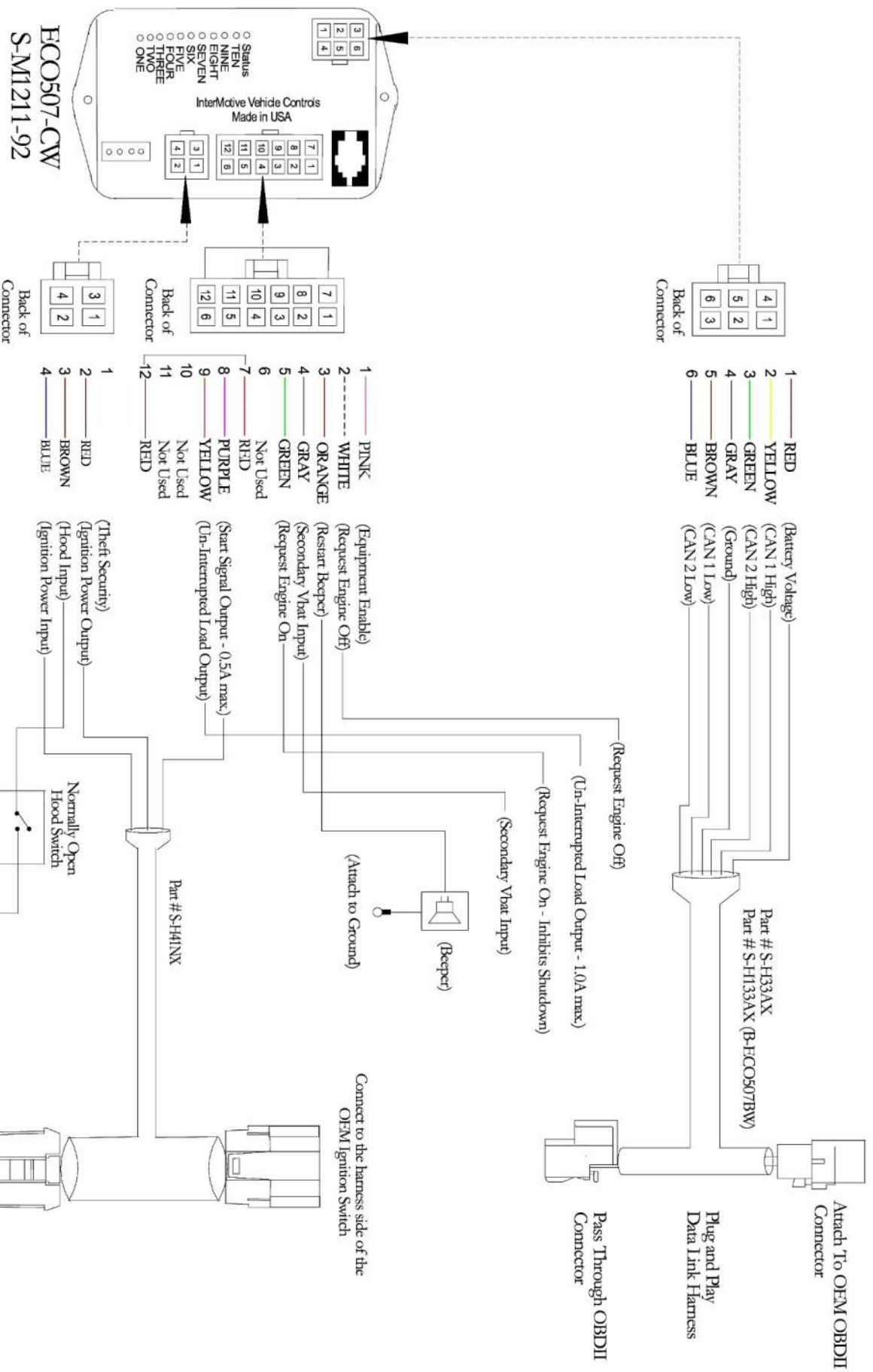

Submit product registration at www.intermotive.net

If the ECO507-CW fails any step in the Post Installation Test, review the installation instructions and check all connections. If necessary, call Intermotive Technical Support at (530) 823-1048.