

## Eco-Star model ECO507-CT (Transit Applications)

2011-2014 Ford F150

2011-2016 Ford F250-F600

2015-2017 Ford F150 (\*B-ECO507-CT)

2017-2022 Ford F250-F600 (\*B-ECO507-CT)

2021-2022 Ford E-Series (\*B-ECO507-CT)

2022 Ford F650-F750 (\*B-ECO507-CT)

\*Uses the Ford 24-Pin Data Link Harness



### Introduction

The Eco-Star ECO507-CT is an automatic engine stop/start system that provides enhanced fuel economy, lower vehicle emissions, and allows an operator to remotely control engine stop/start. Vehicle fuel economy is improved by automatically shutting off the vehicle's engine to prevent unnecessary idling. Restarts can be automatically triggered by low battery voltage, applying the Service Brake or user restart requests. With the battery charge protect feature, auto restarts can prevent a dead battery situation. Two separate battery system inputs allow auto restarts from either battery source. Additionally, a user has the ability to request the ignition to remain off after a shutdown, thus minimizing the draw on the battery and further reducing engine idle time. A hood switch interlock input disables the system when the hood is open. Auto restarts are preceded by a warning beeper sound.

If a temperature activated auto-restart is desired, an optional thermistor may be attached to the Engine On input. Instructions for this option can be found in the Eco-Star App Notes found at [www.Intermotive.net](http://www.Intermotive.net).

The following are the default vehicle safety and conditions for Auto Stop and Auto Restart. These and other parameters may be altered to suit specific needs, using a laptop and InterMotive communication cable. (See ECO-App Note).

Auto Stop Defaults	Auto Restart Defaults
Battery Voltages > 11.8V	Vehicle Hood = Closed
Engine Temp > 170 F Gas / 120 F Diesel	Trans Range = Park or Neutral (Speed = 0)
Trans Range = Park or Neutral (Speed = 0)	Engine Auto-Stopped by ECO507-CT
Outside Air Temp > 32° F and < 100° F	Ignition Key in Run Position
Engine On Request = Not Active	
Brake Pedal = Not Pressed	
Vehicle Hood = Closed	

When all of the Auto Stop Defaults are met, the ECO507-CT will automatically stop the engine. The engine will shut off when the idle timer expires or an external discrete wire Ignition Off Request is activated. The default idle timer is set to 15 seconds.

Engine restart is initiated automatically by a low battery voltage, or the application of a user restart input. There are two separate battery sources that can be configured to trigger a battery charge protect restart. By default, the restart voltage is set to 11.8 Volts for the main battery with a recharge period of at least 60 seconds. The secondary battery input is turned off by default, though it is capable of monitoring up to a 48 Volt input.

### ECO507 Add-on Options

ECO507 CT-T: Thermistor for temperature activated Auto Restart.

ECO507 CT-B: Hood Switch to allow Auto Restart only when hood is closed.

## Installation Instructions

**Disconnect vehicle battery before proceeding with the installation.**



**WARNING**  
Disconnect the battery to prevent setting a check engine light.

### IMPORTANT—READ BEFORE INSTALLATION

It is the installer's responsibility to route and secure all wiring harnesses where they cannot be damaged by sharp objects, mechanical moving parts and high heat sources. Failure to do so could result in damage to the system or vehicle and create possible safety concerns for the operator and passengers. Avoid placing the module where it could encounter strong magnetic fields from high current cabling connected to motors, solenoids, etc. Avoid radio frequency energy from antennas or inverters next to the module. Avoid high voltage spikes in vehicle wiring by always using diode clamped relays when installing upfitter circuits.

### ECO507-CT Module

Remove the lower dash panel below the steering column and find a suitable location to mount the module. Locate the module in an area away from excessive heat sources (engine, heater ducts, etc.). Ensure when routing harnesses that the tilt steering column does not contact them in the full down position. When installing the harnesses, leave several inches of take-out so the module can be removed if necessary. Do not mount module until all wire harnesses are routed and secure. The last step of the installation is to mount the module.

### Data Link Harness (6-Pin Connector)

1. Locate the vehicle's OBDII Data Link Connector, mounted below the lower left dash panel.
2. Remove the mounting screws for the OBDII connector. Plug the Red connector from the ECO507-CT Data Link Harness into the vehicle's OBDII connector. Ensure the connection is fully seated and secure with the supplied wire tie.
3. Mount the Black pass through connector from the ECO507-CT Data Link Harness in the former location of the vehicle's OBDII connector.
4. Secure the ECO507-CT Data Link harness so that it does not hang below the lower dash panel.
5. Plug the free end of the Data Link harness into the mating 6-pin connector on the ECO507-CT module.

Data Link Harness plugs in here



## Installation Instructions (Continued)

### Ford 24-pin Data Link Harness (6-pin connector)

1. Locate the vehicles Gateway Module. It will be mounted below the lower left dash panel.
2. Remove the harness behind the Gateway module by pressing the locking tab and pulling outward.
3. Plug the Female side of the InterMotive Gateway Harness into the back of the Gateway module. Ensure the connection is fully seated and secured by the locking tab.
4. Plug the Male side of the InterMotive Data Link Harness into the Gateway harness.
5. Secure the PRPC Gateway harness so that it does not hang below the lower dash panel.

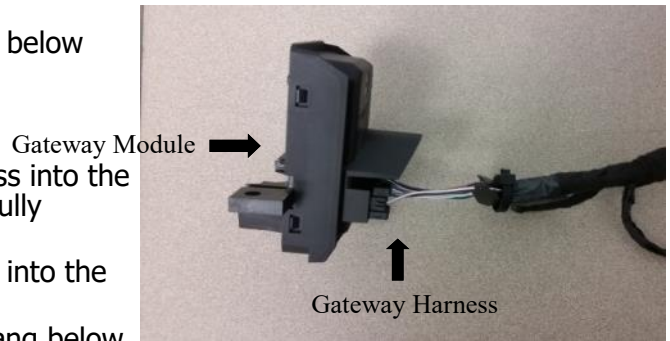

### Ignition Switch Connections

1. Remove the lower steering column trim cover. Locate the ignition switch connector (C250) and disconnect it from the ignition switch.
2. Install the ECO507-CT harness between the Ignition Switch and the OEM connector.
3. Plug the ECO507-CT 12-Pin connector into the mating 12-Pin connector on the ECO507-CT module.
4. Plug the ECO507-CT 4-Pin connector into the mating 4-Pin connector on the ECO507-CT.

**F Series  
C250  
Front of  
Connector**

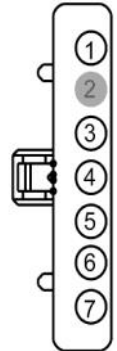

## I/O Features and Descriptions (Solder and heat shrink all connections)

### Hood Open Disable Switch

The Hood Open Disable Switch is **not** an optional input. This grounding connection **must** be made in order for the module to operate. It is one of the most important safety features and the time must be taken to properly install a switch such that a ground contact is made only with the hood fully closed .

Pin #3 (Brown wire) of the 4 pin connector is the Hood Open Disable input. A ground signal prevents auto restart when the hood is open. As an important safety feature, this connection **must** be made to prevent auto restarting when someone is working under the hood area. Extend the Brown Hood Open Disable wire through the bulkhead into the engine compartment (solder and heat shrink all connections). Attach the Hood Open Disable wire to a normally open hood switch that grounds this signal when the hood is closed. A low current switch with gold contacts is recommended.

### Engine Off Request Input

Pin #2 (White wire) of the 12 Pin Connector is an Engine Off Request input. Connect this input to a grounding switch that activates whenever engine off is desired (e.g. passenger door, driver door, or lift door opening).

### Engine Start Request Input

Pin #5 (Green wire) of the 12 Pin Connector is the Engine Start Request Input. A lift door switch should be connected to this input. Once the input is grounded, the engine will restart (if Off) and remain On until either the Transmission or Key is cycled.

### Security Input

Pin #1 of the 4 Pin Connector is an optional security input. When this input is grounded by a switch, the engine will auto shut off if the Transmission is shifted out of Park. A hidden keyed switch could be used for added security. Connect one of the provided Molex pins to an installer supplied wire and insert into cavity 1 of the 4 pin Molex header. Connect free end of wire to installer provided switch.

### Aux Battery Input

**(Up to 48 Volts if build number is labeled as 30-518 on White box on circuit board. Up to 36 Volts if labeled anything other than 30-518 in White box).**



Pin #4 (Gray wire) of the 12 Pin Connector is an auxiliary battery voltage monitor input. It measures the analog battery input and can trigger a low battery restart when this input falls below a user defined level. By default, this trigger is disabled, but it may be enabled via a laptop connection. Contact InterMotive for details or refer to Eco-Star Application Note. A spare Molex pin is provided in the kit to allow the use of this input.

## I/O Features and Descriptions (continued)

### Restart Beeper

Pin #3 (Orange wire) of the 12 Pin Connector drives a warning beeper that will sound for 2 seconds prior to a low battery restart.

1. Find a suitable location for mounting the warning beeper so that it is audible to the driver.
2. Connect the Orange lead to Red post of beeper and the Black lead to the negative post.
3. The Black lead eyelet must be grounded in order for the beeper to function.

The bezel on the beeper can be rotated to control volume.

### Hot in Run / Start Output

ECO507-CT shuts down the vehicle's engine by simulating a "key off" condition. All electrical loads that are powered from the hot in Run/Start circuit will momentarily lose power when the engine is turned off. This may not be desirable for all loads and can be modified by re-wiring any loads to retain power to the Run/Acc circuit, or wire an external relay to Eco-Star's Hot in Run/Start Signal Pin #9 Yellow wire (1 Amp max, see below). This signal simulates the hot in Run/Start signal with the exception that it will not momentarily drop out when Eco-Star shuts the engine off. Keep in mind that any additional loads will drain the battery faster, resulting in a low voltage restart. Use of LED lights and higher capacity batteries is recommended to maximize engine off time.

### Equipment Enable Output

The equipment enable output will force the user to depend on Eco-Star stop/start capability in order to use their equipment. This load is only active when the Request Engine Off input is active and the vehicle is in Park. While this input is active, Eco-Star will cycle the engine based on primary/secondary battery Voltages and the Request Engine On input (which now includes the optional thermostat function).

The Equipment Enable Load Output is similar to the Hot in Run / Start Output. The difference is that this load ensures that Eco-Star is cycling the engine. In the case of Hot in Run / Start Output, there are ways to disable the stop/start capabilities of Eco-Star (disable idle timer or set to 30 minute idle time) while retaining the output.

The Pin #9 (Yellow wire) and Pin #1 (Pink wire) output are capable of driving up to 1 Amp max. When connecting to a relay, always use a diode clamped relay, such as Digikey part number PB682-ND, or add a diode across the relay coil as shown, observing the required diode polarity. The use of a relay without diode clamped suppression causes high voltage spikes when the relay coil is deactivated. These voltage spikes may cause damage or intermittent behavior to on-board vehicle control modules. Resistors and other methods of clamping are not as effective and are not recommended.

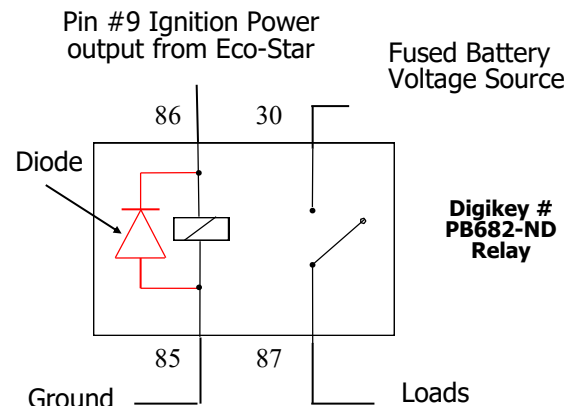

### ECO507-CT Module Mounting

Ensure all harnesses are properly connected and routed, and are not hanging below the dash area. Mount the module as described on page one, and secure with screws or double sided tape.

## Reconnect vehicle battery

## Post Installation Operational Test

### Setting module into Installation Test Mode

The installation test mode can be entered by applying a ground to the silver pad on the module labeled "TEST". When test mode activates, the status LED will start blinking; the ECO507-CT now functions without monitoring the following pre-conditions: Engine Temp, Battery Voltage, or Ambient Air Temp (when applicable). This allows for easier testing/troubleshooting for the installer.

Several conditions will prevent ECO507-CT from auto-shutdown in test mode:

Trans Range Not in Park or Neutral, Service Brake Pedal Applied, Hood Open (Open = Not Grounded), Vehicle Speed not 0, or Shutdown Inhibit Input Active (Grounded).

**Test 1.** With engine running, transmission in Park or Neutral, hood closed, activate the Engine Off Request input. Engine will shut off and Ignition will go off for several seconds before Run/Start Output is restored.

**Test 2.** Apply the Service Brake. The Engine will automatically restart.

**Test 3.** Release the Service Brake and confirm the module shuts off the engine after 15 seconds. Note: Applying the Service Brake resets and prevents the timer from counting down and shutting off the engine.

**Test 4.** With the engine still auto-stopped, open the hood and repeat test 2. As a safety feature, the ECO507-CT **MUST NOT** start or stop the engine when the hood is open. If applying the Service Brake starts the engine with hood open, check hood switch wiring.

**NOTE:** ECO507-CT will not shut off the engine for 5 seconds after the engine is started.

**Do not put vehicle in service unless hood open disables Eco-Star from auto restarting engine.**

**If the system fails any of the above tests, check the related wiring. If necessary, call InterMotive Technical Support. Do NOT release vehicle for service unless it has passed ALL of the above tests.**

### Want to change default settings?

To make changes to the default Eco-Star configuration, see InterMotive Application Note for the ECO507 on our website ([www.intermotive.net](http://www.intermotive.net)). This document goes into much greater detail on the parameters and safety conditions of Eco-Star. If the configuration is altered, make note of the modifications for future serviceability and include them with the vehicle.



An ISO 9001:2015 Registered Company

## Leave in Vehicle Operating Instructions Eco-Star model ECO507-CT (Transit Applications)

2011-2014 Ford F150

2011-2016 Ford F250-F600

2015-2017 Ford F150 (B-ECO507-CT)

2017-2022 Ford F250-F600 (B-ECO507-CT)

2021-2022 Ford E-Series (B-ECO507-CT)

2022 Ford F650-F750 (B-ECO507-CT)

- The ECO507-CT provides enhanced fuel economy and lower vehicle emissions by limiting engine idle time. Vehicle fuel economy is improved by automatically shutting off the vehicle's engine to prevent unnecessary idling. After an auto shutoff has occurred, restarts can be automatically triggered by low battery voltage or applying the Service Brake.
- The Engine Off Request is a input that, when activated, stops an idling engine by switching off ignition power. Usually this is connected to the passenger door, such that loading passengers (in Park) will shut off the engine. Once the vehicle is turned off, it will can be automatically restarted by either low battery voltage or applying the Service Brake. It can also be restarted with the key.
- The Engine will also be shut off when the idle time exceeds the time out period. The default timeout period is 15 seconds of idling in Park or Neutral. After that period elapses, the engine will be automatically turned off. Note that the Service Brake and the Shutoff Inhibit input will prevent idle timer shutoff.
- The Shutoff Inhibit input is a trigger that, when activated, will prevent the engine from auto stopping. If connected, this input may be connected to the vehicle's Heater or A/C or other equipment.
- Once the engine has been auto-stopped, ECO507-CT monitors the battery voltage. If it falls too low, the module will sound an alarm and auto-restart the engine to recharge the battery. Once it is determined that the battery has been sufficiently recharged, the engine will shut off again.
- If a security switch has been installed and is "on", the engine will be turned off if the transmission is shifted out of Park. This can prevent theft and/or unauthorized driving.

### Default requirements for auto engine shut off

Transmission in Park or Neutral (vehicle not moving)

Hood Closed

Service Brake not applied

Battery having sufficient charge

Engine must be warm

No thermostat trigger

Outside temperature above 32 ° F and below 100 ° F. (not supported on 6.0 or 6.4 L diesels)

Inhibit Shutdown input (if used) must not be "on." (this switch input overrides the Engine Off Request and the Anti-Idle Timer)

Note: The module will not respond to an Engine Off Requests for 5 seconds after the engine is started.

### Default requirements for auto engine restart

- Engine must have been auto-stopped.
- Transmission in Park or Neutral, and the key remained in the Run position.
- Hood Closed.

Once the above conditions are met, the engine will restart when the brake pedal is applied, a low battery is detected or the thermostat triggers a restart.

The ECO507-CT may be removed from the vehicle by unplugging the ECO507-CT 6 pin harness (behind lower drivers dash panel) and restoring the OEM ignition switch wiring. (under steering column trim cover)

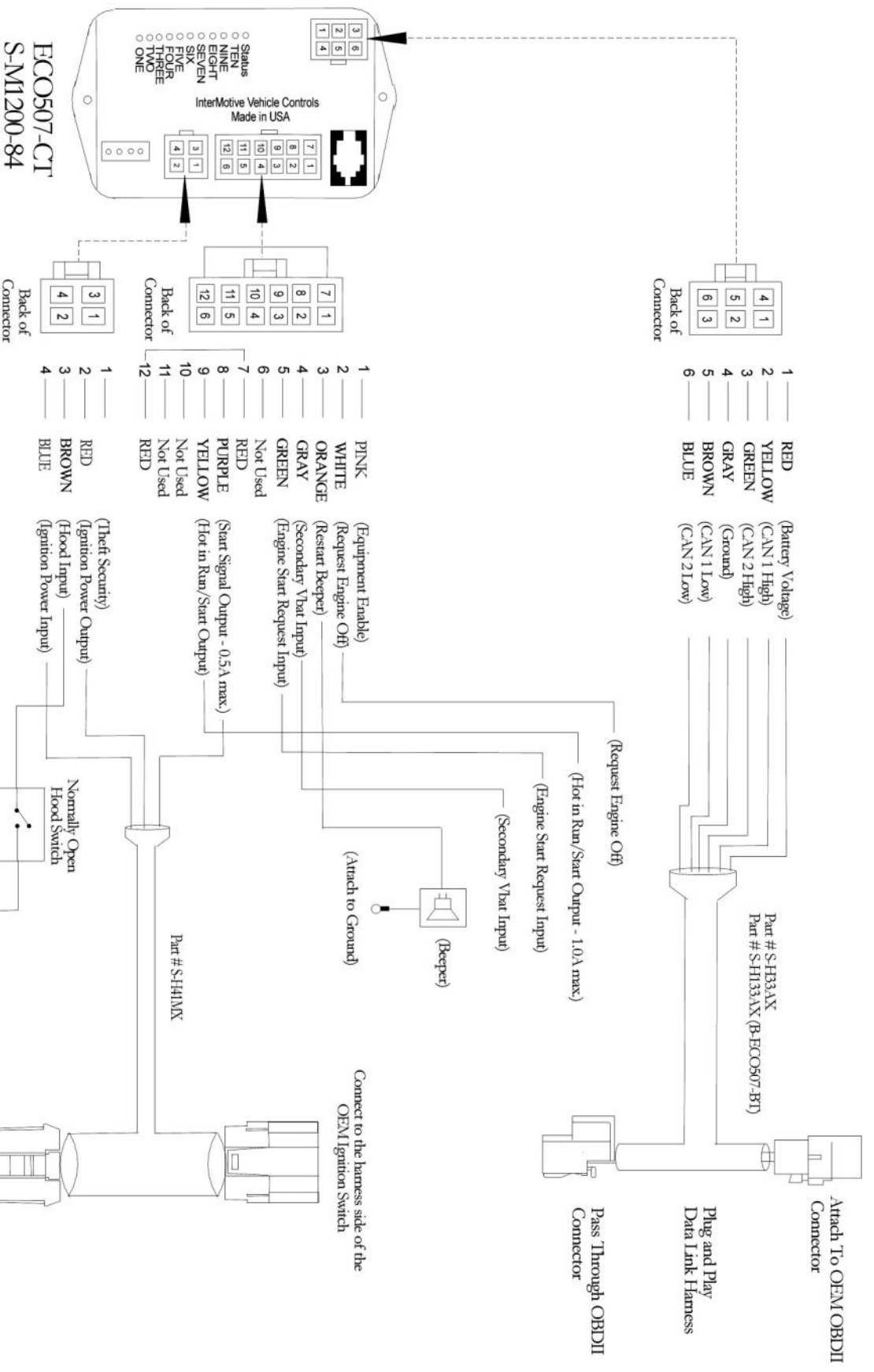

**Submit product registration at [www.intermotive.net](http://www.intermotive.net)**

If the ECO507-CT fails any step in the Post Installation Test, review the installation instructions and check all connections. If necessary, call Intermotive Technical Support at (530) 823-1048.