

Instructions



EcoStar™ III

E-EC03-751-A 2019-2024 Ram 2500-5500 with Column Shift

System Overview

Introduction

EcoStar™ III (ESIII) is a configurable automatic engine stop/start system that provides improved fuel economy, lower vehicle emissions, improved engine life, and extended oil changes by shutting off the engine when appropriate. Automatic engine restarts are triggered by multiple configurable parameters: primary or auxiliary battery voltage, service brake, thermistor temperature and auxiliary restart input. Auto-restarts are preceded by a warning beeper sound. Battery charge protect prevents a dead battery when loads are left on. Two separate battery system inputs allow auto restarts from either a primary or auxiliary battery source. ESIII can fast idle the engine (gas only) based on configurable triggers: primary or auxiliary battery voltage, park brake, AC, heater boost, an external input, and thermistor temperature. A hood switch interlock input disables the system when the hood is open.

EC03-751 has two main modes of operation: fob in cabin and fob out of cabin. With the fob in the cabin, the system does not require any driver interaction. This passive operation leads to greater fuel savings. With the fob out of the cabin, the system provides more security. During fob out operation the shifter is locked in the Park position.

The following are the default vehicle safety and functional pre-conditions for Auto Stop and Auto Restart. These and other parameters may be altered to suit specific needs. A new configuration file can be loaded with the InterMotive Download Manager. Configuration changes can be made with the InterMotive EcoStar™ III Mobile App.

Auto Stop Defaults	Auto Restart Defaults
Vehicle Hood = Closed	Vehicle Hood = Closed
Trans Range = Park or Neutral (speed = 0)	Trans Range = Park or Neutral (Speed = 0)
Fob in Cab or Fob Out Mode Active	Fob in Cab or Fob Out Mode Active
Battery Voltages > 12.0 V	Engine Auto-Stopped by ESIII
Brake Pedal = Not Pressed	
Engine On Request = Not Active	
Thermistor Trigger = Not Active	

When all Auto Stop conditions are met, the ESIII will automatically stop the engine when the timer expires or an external discrete wire Ignition Off Request is activated. The default timer is set to 15 seconds.

ESIII Versions and Supported Vehicles

Make sure the version of EcoStar™ III you are installing is the correct one for you vehicle. There may be new vehicles or model years added. If you don't see your vehicle or model year below, please check with InterMotive.

E-EC03-751 2019-2024 Ram 2500-5500 with Column Shifter

ESIII Add-On Options

- T: Thermistor for temperature activated Auto Restart.
- B: Hood Switch to allow Auto Restart only when hood is closed.

Instructions

IMPORTANT — READ BEFORE INSTALLATION

It is the installer's responsibility to route and secure all wiring harnesses where they cannot be damaged by sharp objects, mechanical moving parts and high heat sources. Failure to do so could result in damage to the system or vehicle and create possible safety concerns for the operator and passengers.

Avoid placing the module where it could encounter strong magnetic fields from high current cabling connected to motors, solenoids, etc. Avoid radio frequency energy from antennas or inverters next to the module. Avoid high voltage spikes in vehicle wiring by always using diode clamped relays and solenoids when installing upfitter circuits.

CAUTION

All electronic products are susceptible to damage from Electrostatic Discharge or ESD. Ground yourself before handling or working with the module and harnessing by first touching chassis ground, such as the barrel of the cigarette lighter.



Installation Instructions

Disconnect vehicle battery before proceeding with installation.



WARNING

Disconnect the battery to prevent setting a check engine light.

ESIII Module

Remove the lower dash panel below the steering column and find a suitable location to mount the module. Locate the module in an area away from excessive heat sources (engine, heater ducts, etc.). Ensure when routing harnesses that the tilt steering column does not contact them in the full down position. When installing the harnesses, leave several inches of take-out so the module can be removed if necessary. Do not mount module until all wire harnesses are routed and secure. The last step of the installation is to mount the module.

Instructions

Installation Instructions (continued)

Data Link Harness

1. Locate the vehicle's OBDII Data Link Connector. It will be mounted below the lower left dash panel.
2. Remove the mounting screws for the OBDII connector. Plug the Red connector from the Data Link Harness 840-00026 into the vehicle's OBDII connector. Ensure the connection is fully seated and secure with the supplied wire tie.
3. Mount the Black pass through connector from the Data Link Harness in the former location of the vehicle's OBDII connector.
4. Secure the Data Link Harness so that it does not hang below the lower dash panel.
5. Plug the free end of the Data Link Harness into the extended harness which then plugs into the mating 6-pin connector on the module.
6. Locate the STAR connector bank in the location shown (next to the Park Brake).

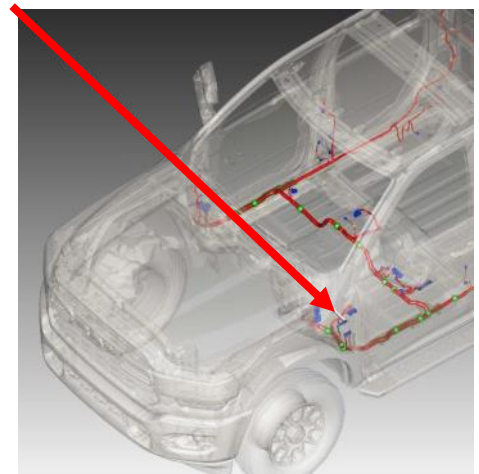

7. There are multiple banks of Star connectors. One of the banks has a black base and the other has a white base.
8. Plug the Data Link Harness 2-pin connector with **Yellow and Brown wires** into one of the unused ports with the **Black base**.
9. Plug the Data Link Harness 2-pin connector with **Green and Blue wires** into one of the unused ports with the **White base**.

NOTE: If a 2-pin connector is inserted into the wrong bank the LEDs on the module will scroll with LEDs 1 or 2 on the module on constantly.



Instructions

Shift Lock connector for Vehicles with Column Shifter ONLY

Shift lock on column shifters must be done discretely using a relay on the Intermotive Module.

1. The BTSI (Brake Shift Transmission Interlock) connector is located behind the steering wheel. To access the connector the driver knee panel must be removed.
2. The BTSI is a 4 pin connector seen in the picture below.
3. Remove the OEM connector from the shift lock solenoid.
4. Install the Intermotive harness between the OEM harness and the shift lock solenoid.

Isometric View:

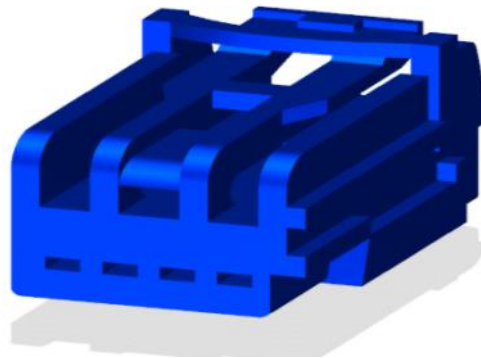

Ignition Switch Harness

1. Locate the vehicle's ignition switch connector located behind the ignition switch.
2. Remove the connector from the ignition switch (push in on tab and pull out).
3. Install the ECO3 harness between the ignition switch and the OEM harness.



Instructions

Fob Out Activation Button Installation

A push button with an integral LED is provided in the kit (Part #S-H84GX).

1. Drill a 16mm (0.630") hole in the desired mounting location. One possibility is the dash panel to the left of the Steering Wheel.
2. Remove the lock nut from the LED button and route the harness through the hole. Mount the button in the hole.
3. Slide the button's lock nut onto the harness and snug it down onto the back of the LED.
4. Plug in the 4-pin (Black) connector of the button harness into the mating connector on the E-ECO3-751 main harness.



Key Fob Box

A spare key fob will need to be modified and inserted into the provided enclosure to allow the E-ECO3-751 system to work with the key fob outside of the vehicle.



1. Remove the physical key from the key fob.



2. Separate the key fob using the physical key.



Instructions

Key Fob Box (continued)

3. Remove the battery from the fob.



4. Install the Intermotive battery (830-00050-01) board into the key fob. Be aware that the battery board has 4 areas on the outer edges with no copper. Ensure that the copper will touch both of the contacts on the key fob.

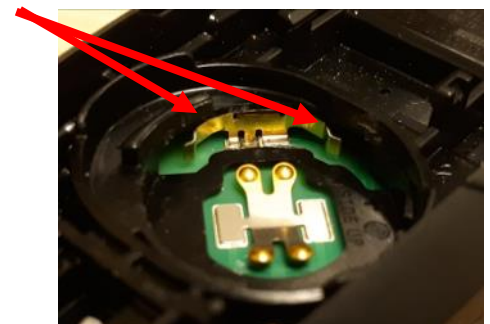
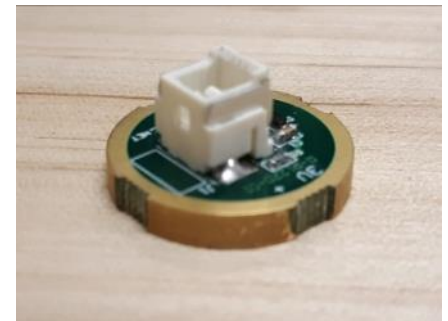

Instructions

Key Fob Box (continued)

5. Install the Intermotive plastic battery board retainer (**432-00004**).



6. Plug the 2-pin White connector into the battery board and route the harness toward the hole in the side of the box. Place the rubber grommet in the hole as shown.



7. Place the top portion of the box on top and secure it with the 4 included screws.



8. Plug the 3 pin connector into the mating connector on the main harness.

9. Mount the enclosure with fob inside in a hidden location.

Instructions

I/O Installation, Features and Descriptions: (Solder and heat shrink all connections)

Key Fob Out Enable Input

Pin #2 (Gray wire) of the 8 pin J4 Connector is the Key Fob Out Enable input. This input connects to momentary switch supplied in the ESIII kit. This enable input is high true (12V). When the momentary button is pressed and released, an LED integral to the button will flash rapidly. Then the user can remove the key fob from the cabin within a pre-configured amount of time to activate key fob out mode. The default period of time is 10 seconds. If key fob out mode is successfully activated, the integral LED will continue to flash every two seconds. If the key is not removed within the time period the LED will flash rapidly and stop flashing.

Ignition/Engine Off Request Input

Pin #4 (White wire) of the 8 Pin J4 Connector is an Engine Off Request input. Grounding this wire with a switch allows remote engine shutoff capability. Keeping this input grounded will keep the ignition switch power off (exceptions: a remote Engine On Request, low battery OR thermistor restart trigger **will** restore ignition power and restart the engine). Leaving the ignition off after an Engine Off request reduces the draw on the battery to a minimum, allowing the greatest amount of time between low battery restarts.

Engine On Request Input

Pin #6 (Green wire) of the 8 Pin J4 Connector is the Engine On Request input which may be wired to vehicle equipment which requires the engine to continue running. A blunt cut Green White wire is available approximately 4" up the main harness loom for a switch connection. **This switch input must provide a ground when restart is desired.** Solder and heat shrink all connections. This input also acts as a Shutdown Inhibit. As long as it is active (grounded), the Anti-Shutdown Timer and the Request Engine/Ignition Off inputs will not turn the vehicle off.

An optional thermistor may be attached to the Engine On input if a temperature activated auto-restart is desired. The thermistor plugs into the 2-pin connector with Green and Black wires available in the harness take out approximately 4" up the main harness loom. The thermistor option may be used to auto restart the engine as a result of either cold or hot temperatures. For example, it may be used to prevent the engine from getting too cold in severe environments. It may also be used in police K9 vehicles to prevent cabin temperature extremes. Mount the thermistor in a location where it cannot be damaged by sharp objects and mechanical moving parts such as the Park Brake or tilt steering wheel mechanisms.

- **Thermostat Engine Cycling** Assumes the cabin heater or air conditioner is turned on. If after 6 minutes, the cabin temperature does not increase for low temperature restart or decrease for a high temperature restart the thermostat is disabled until the key is cycled.

Hood Open Disable Switch

The Hood Open Disable Switch is **not** an optional input. This grounding connection **must** be made in order for the module to operate. It is one of the most important safety features and the time must be taken to properly install a switch such that a ground contact is made only with the hood fully closed.

Pin #7 (Brown wire) of the 4 pin connector is the Hood Open Disable input. As an important safety feature, this connection must be made to prevent auto restarting when someone is working under the hood area.

The wire has a female bullet applied to the end. A male bullet is included in the kit. Install the included male bullet connector on a wire that extends through the bulkhead into the engine compartment. Attach the wire to a normally open hood switch that grounds this signal when the hood is closed. A low current switch with gold contacts is recommended.

Instructions

I/O Features and Descriptions (continued)

Aux Battery Input (Up to 60 Volt)

Pin #8 (Gray wire) of the 8 Pin J4 Connector is an auxiliary battery voltage monitor input. It measures the analog battery input and can trigger a low battery restart when this input falls below a user defined level. By default this trigger is disabled, but it may be enabled via the ESIII mobile app. Contact InterMotive for details.

Restart Beeper

Pin #2 (Orange wire) of the 4 Pin J5 Connector drives a warning beeper that will sound for 2 seconds prior to all restarts except Service Brake restarts.

1. Find a suitable location for mounting the warning beeper so that it is audible to the driver.
2. Connect the Orange lead to Red post of beeper and the Black lead to the negative post.

Rotate the bezel on the beeper to control volume.

Configurable Low Current Outputs

Output 1 Pin #3 of J5 (Yellow wire) (0.5 Amp Max)

Output 2 Pin #4 of J5 (Pink wire) (1 Amp Max)

Output 3 Pin #1 of J12 (Tan wire) (0.5 Amp Max)

Output 4 Pin #2 of J12 (Light Green wire) (0.5 Amp Max)

These outputs can be configured with one of the following 9 logic modes.

1. Lock Mode

When configured for lock mode, an output can control installer supplied normally closed relays to secure equipment when fob out is active (e.g. trunk and weapon rack release buttons in police applications). When ESIII activates this output, the relays will open the circuits from the buttons and disable them. This minimizes possible theft when ESIII is active and the vehicle is unattended.

When ESIII is enabled, this output becomes active after a configurable delay. (default 10 seconds) This output remains active until the key is back in the run position.

If an attempted theft is detected and ESIII disables, this output will still remain active until the key is back in the run position.

2. Key Fob Out Active

An output using this logic mode can control installer supplied normally closed relays or auxiliary indicator LEDs. This output can enable/disable equipment while ESIII is cycling the engine in key fob out mode. When key fob out operation is enabled, this output becomes active. This output remains active until the key is back in the cabin.

If an attempted theft is detected and ESIII disables, **this output will turn off.**

3. Equipment Enable

An equipment enable output will force the operator to depend on ESIII stop/start capability in order to use their equipment. This output is only active when the Request Engine Off input is active. While this input is active, ESIII will cycle the engine based on primary/secondary battery Voltages and the Request Engine On input (which includes the optional thermostat function).

The Equipment Enable Load Output is similar to the Un-Interrupted Load Output. The difference is that this load ensures that Eco-Star is cycling the engine. In the case of the Un-Interrupted Load Output, there are ways to disable the stop/start capabilities of Eco-Star (disable timer or set to 30 minute time) while retaining the output.

Instructions

4. Un-Interrupted Load Control

ESIII shuts down the vehicle's engine by simulating key OFF or ACCESSORY condition. All electrical loads that normally shut off when the key is in the simulated position will lose power. This may not be desirable for all loads and can be avoided by wiring an external relay to an ESIII output configured with this mode (continue reading for proper relay wiring).

The Ignition Power Signal will normally activate only when the key is in the Run/Start position. However, when EcoStar is commanding Ignition Off, the Ignition Power Signal becomes Key In Ignition. These loads will drain the battery faster. Use of LED lights and higher capacity batteries is recommended.

5. Engine Run

An output with this logic mode will turn on when the engine is running. This logic mode can be used to disable equipment when the engine is not running.

6. Theft Alarm

The output will pulse during theft alarm sequence. Connect to auxiliary visual or audible alarm equipment.

7. AFIS Trigger

The output will activate when the AFIS conditions are met to trigger fast idle. Fast Idle on diesel engines is available on 2023+ vehicles.

8. Door Lock

The output will activate for 250 ms when the OEM doors are locked. This output can be connected to non-OEM locks for doors or storage containers.

9. Door Unlock

The output will activate for 250 ms when the OEM doors are unlocked. This output can be connected to non-OEM locks for doors or storage containers.

Pin #3 of J5 (Yellow wire), Pin #1 of J12 (Tan wire), and Pin #2 of J12 (Light Green wire) are capable of driving up to 0.5 Amp max. Pin #4 of J5 (Pink Wire) is capable of driving up to 1 Amp max. When connecting to a relay, always use a diode clamped relay, such as Digikey part number PB682-ND, or add a diode across the relay coil as shown, observing the required polarity. The use of a relay without diode clamped suppression causes high voltage spikes when the relay coil is deactivated. These voltage spikes may cause damage or intermittent behavior to on-board vehicle control modules. Resistors and other methods of clamping are not as effective and are not recommended.

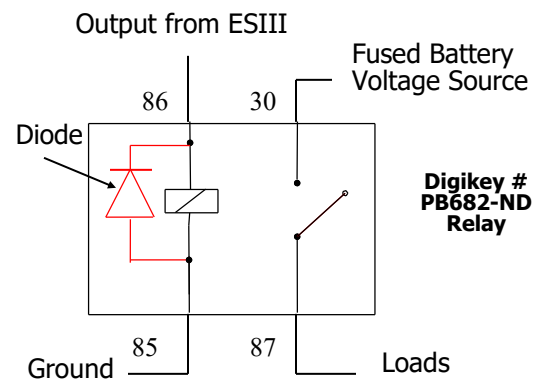

Configurable Shift Lock/Fast Idle Input

Pin #3 of J4 (Yellow Blue wire) (+12V) is a configurable input. ESIII can use this input as a shift lock trigger, a fast idle trigger, or both. The configuration can be adjusted with the EcoStar III mobile app. While +12V is applied to this input EcoStar III will perform the configured function. Fast Idle for diesel engines is available on 2023+ vehicles.

Instructions

Automatic Door Lock & Unlock with AutoSense™ technology (820-2400-004)

During fob out operation, ESIII can automatically lock and unlock the vehicle doors based on proximity of AutoSense™ fobs. The ESIII kit when ordered with the –L option will come with two bonded AutoSense fobs (pictured below). ESIII will automatically lock the doors when a nearby fob moves beyond the configurable lock range. ESIII will unlock doors when an out of range fob moves within the configurable unlock range.

The configurable lock and unlock range can be adjusted with the EcoStar III mobile application. The settings are on a scale from 0 to 10. Where 0 is nearest and 10 is furthest from the ESIII module. The distance is estimated by the signal strength from the AutoSense fob to the ESIII module which is installation dependent. These settings must be determined by observation after ESIII has been installed on a specific application.



AutoSense™ Fob

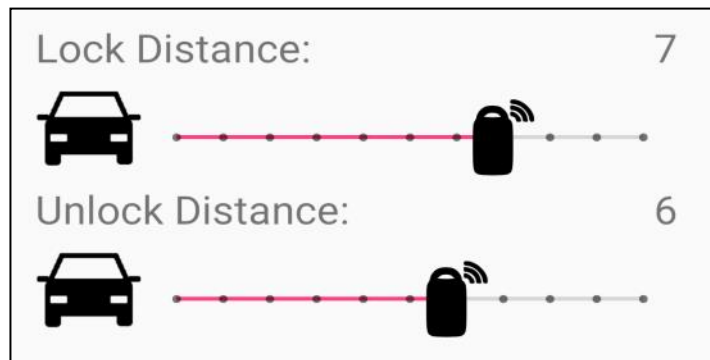

AutoSense™ Configurable Settings

AutoSense™ Add Fob P&R

If ESIII was not ordered with the –L option, it is possible to add AutoSense fobs to the ESIII system for the automatic door lock & unlock function using the following programming sequence.

1. Turn the key in the run position with the engine off and the transmission in park.
2. Press the red test button on the module 9 times to enter diagnostic page 9. The status LED will blink 9 times when on page 9.
3. Press and hold the red test button for approximately 3 seconds until the LEDs flash and then turn off.
4. Cycle the battery on an AutoSense fob and place near the module.
5. The LEDs will flash during the bonding process and turn on solid for 2 seconds when bonding is successful.
6. Repeat steps 4 and 5 to add additional fobs (ESIII will only store the last three fobs).
7. Press test button once more when finished to exit diagnostic mode.

ESIII Module Mounting

Ensure all harnesses are properly connected and routed and are not hanging below the dash area. Mount the module as described on page one, and secure with two screws or double sided tape.

Reconnect vehicle battery

Instructions

Post Installation Operational Test

Test 1. With engine running, transmission in Park or Neutral, hood closed, activate the Engine Off Request switch input. Engine will shut off, ignition will be held off.

Test 2. Release the Engine Off Request. Ignition power will be restored, loads that are powered with key in Run will be restored. Engine will not start (low battery could cause a restart).

Test 3. Activate the Engine On Request input. The Engine will automatically restart.

Test 4. Release the Engine On Request and confirm the module shuts off the engine after *15 seconds. Note: Applying the Service Brake may prevent the timer from counting down and shutting off the engine.

Test 5. Start the engine and enable fob out operation by pressing the enable button and removing the key within *3 seconds. If successful, the LED that is integral with the button will continue to flash.

Test 6. Confirm the module shuts off the engine after *2 seconds.

Test 7. Repeat test 3 with hood open. As a safety feature, the ESIII MUST NOT start or stop the engine when the hood is open. If the Engine Start Request starts engine with hood open, check hood switch wiring.

NOTE: ESIII will not shut off the engine for 5 seconds after the engine is started.

*These values are configurable and may change from the stated default values.

Do not put vehicle in service unless hood open disables EcoStar™ III from auto restarting engine.

If the system fails any of the above tests, check the related wiring. If necessary, call InterMotive Technical Support. Do NOT release vehicle for service unless it has passed all of the above tests.

Want to change default settings?

To make changes to the default EcoStar™ configuration, use the InterMotive EcoStar™ III Mobile App. The app allows you to view or modify any of the ESIII configurable parameters. If the configuration is altered, make note of the modifications for future serviceability and include them with the vehicle.

Instructions

Leave in vehicle Operating Instructions EcoStar™ III E-EC03-751 2019-2024 Ram 2500-5500

- EcoStar™ III (ESIII) provides enhanced fuel economy and lower vehicle emissions for customers by limiting engine time. Vehicle fuel economy is improved by automatically shutting off the vehicle's engine to prevent unnecessary idling. Restarts can be automatically triggered by low battery voltage, Service Brake, remote equipment operator requests, or thermostat restart trigger (if enabled).
- The system can operate with fob in cab (no driver interaction required) or fob out of cab by pressing the fob out enable button and removing the fob within 10 seconds (configurable). During fob out operation the shifter is locked and timer is 2 seconds (configurable). The LED integral with the enable button will flash while fob out is active.
- The Engine Off Request is a remote switch that when activated turns the engine off by switching off ignition power. The ignition remains off until: 1) Engine Off Request is removed, 2) Low battery causes a restart, 3) a remote Engine Start Request switch is activated or 4) Thermostat triggered restart. The module keeps ignition off to reduce the demand on the batteries, thereby delaying a low battery restart as long as possible.
- The Engine will also be auto-stopped when the time exceeds the time out period. The default timeout period is 15 seconds of idling in Park or Neutral. After that period elapses, the engine will be automatically turned off. Note that the Service Brake and the Engine On switch can prevent timer shutoff.
- The Engine On Request switch, if installed, is a remote trigger that, when activated, will start the engine after an auto-stop has occurred. Activating the Engine On Request while the vehicle is running will prevent all auto-stops from occurring. If the vehicle is equipped with the optional thermistor, the vehicle may auto-restart and shut off based on temperature
- Once the engine has been auto-stopped, ESIII monitors the main battery voltage (an auxiliary battery may also be monitored). If either fall below a minimum restart voltage, the module will sound an alarm for 2 seconds and auto-restart the vehicle to recharge the batteries. The default restart value is 12.0 Volts for the main battery (aux battery input is disabled). Once the main battery charges above 13.5 volts, a recharge timer of 900 seconds begins that will turn off the engine again.
- ESIII will fast idle the engine based on configurable triggers: primary or secondary battery voltage, park brake, AC, heater boost and an external input. Fast Idle on diesel engines is available for 2023+ vehicles.
- An ESIII mobile app is available to view reduction stats, view or modify the configuration, and perform system diagnostics.

Default requirements for engine auto-stop

Transmission in Park or Neutral (vehicle not moving), Hood Closed, Service Brake not applied, Battery Voltage greater than 12.0 Volts (may differ from default setting), no thermostat trigger, and Engine Restart switch must not be "on" (this switch input overrides the Engine Off Request and Timer).

Default requirements for engine auto-restart

Hood Closed, Engine must have been auto-stopped, Transmission in Park or Neutral, and the fob in cab or fob out mode active.

Once above conditions are met, the engine will restart when the Engine On Request is activated, a low battery is detected or Thermostat restart trigger is activated.

The ESIII may be removed from the vehicle by unplugging the ESIII 6 pin harness (behind lower drivers dash panel) and restoring the OEM ignition switch wiring (under steering column trim cover).

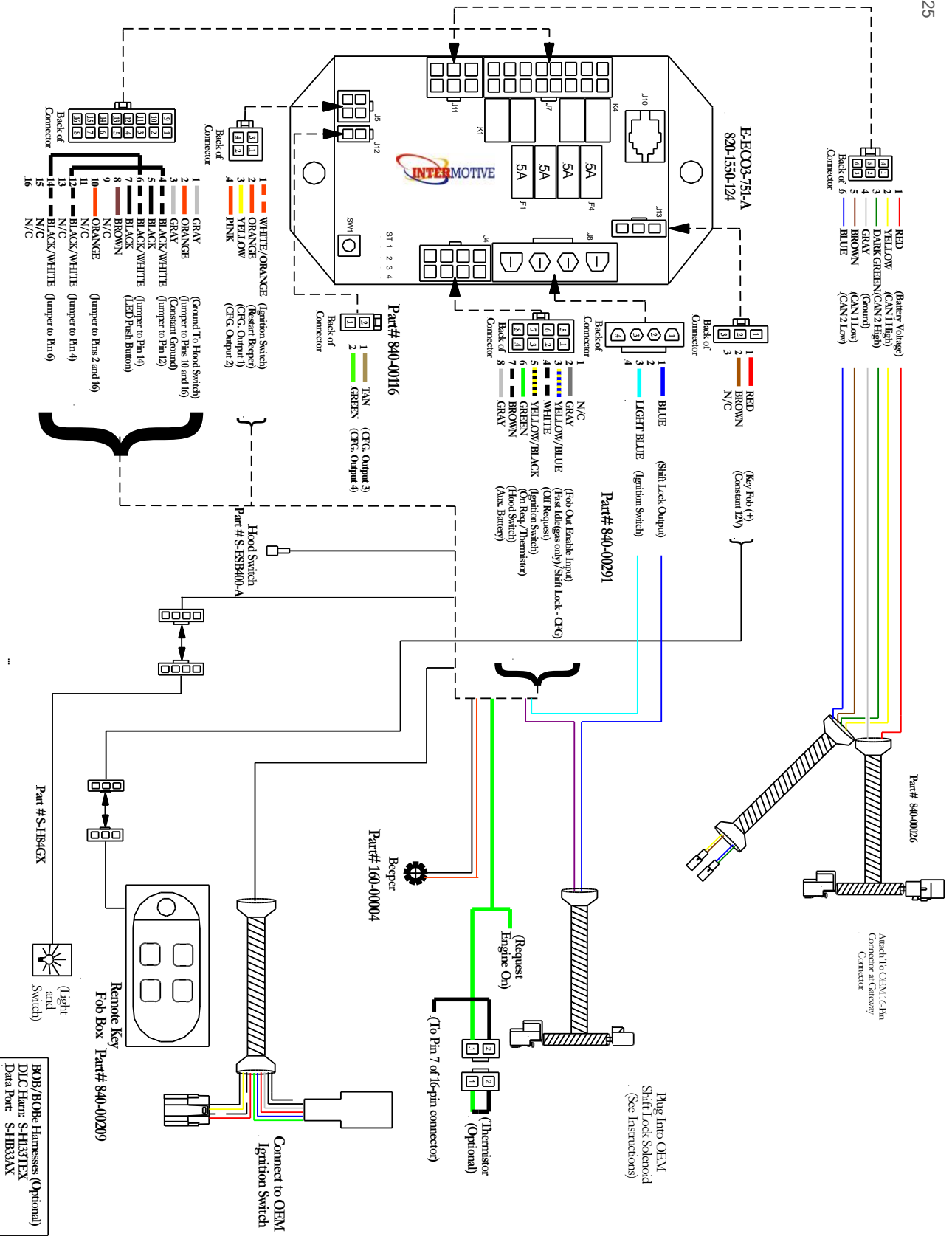

Submit product registration at www.intermotive.net

If the EEC03-751 fails any step in the Post Installation Check List, review the installation instructions and check all connections. If necessary, call Intermotive Technical Support at (530) 823-1048.