

**Door Lock  
Module**

**INTERMOTIVE**  
**VEHICLE  
CONTROLS**

An ISO 9001:2015 Registered Company

# Door Lock Module

Complete Chassis Security

## Overview

- Provides the ability to lock/unlock all doors using a hidden switch, keypad or OEM fob to secure doors remotely
- Controls locks for both the cab and patient compartment
- Specifically designed for Ford chassis

## Features

- Module works on both OEM and aftermarket doors to lock complete chassis
- Triggers locks with ignition either on or off
- Requires minimal connections to OEM wiring
- Includes Intermittent Fault Filter™ (IFF) technology to eliminate false readings

*Product features may vary by make,  
model or year. See instructions  
for complete details.*



Proudly distributed by

**LGS GROUP**  
AUTOMOTIVE TECHNOLOGIES

**(775) 831-2002**

# Details

## EXAMPLE SCHEMATIC

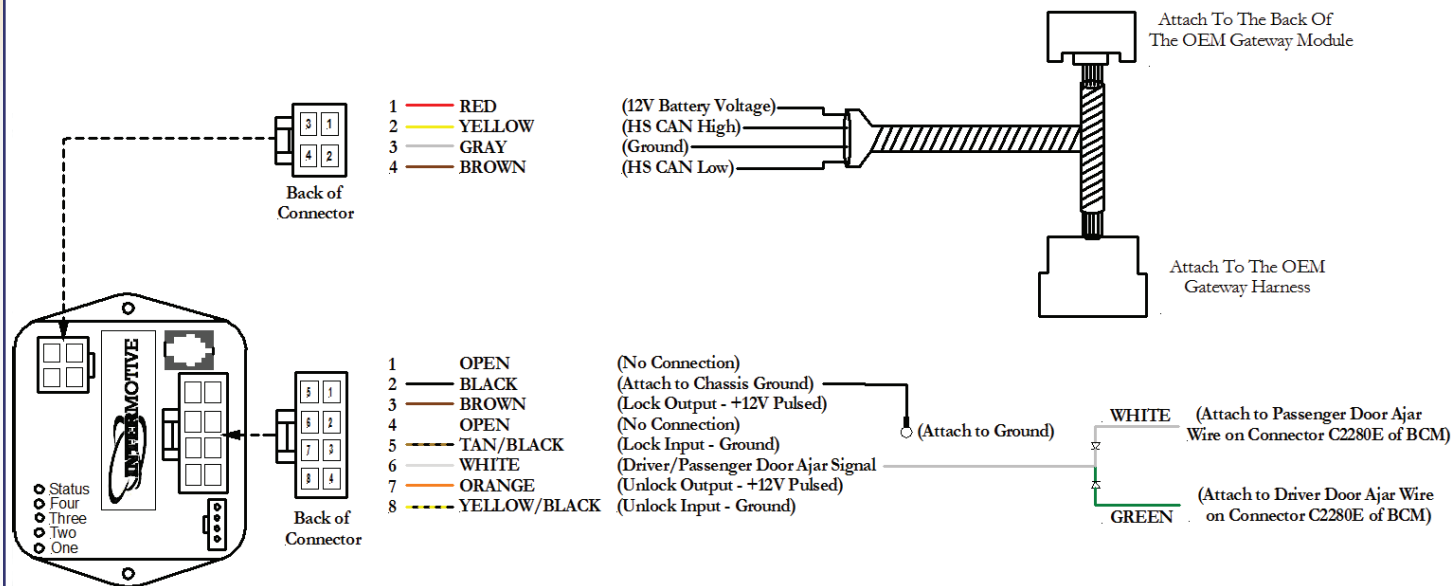

## SPECIFICATIONS

Number of Inputs Two active low inputs (lock and unlock)

Number of Outputs Two active high outputs (lock and unlock)

Current Draw 40 mA

Quiescent Draw 1.2 mA (sleep current)

CAN Speed High speed

Temperature Range -40°C to 80°C

Dimensions 3" L x 2" W x 1" H