

## C-IDLE760-A

**Idle Lock™ with Autosense Technology**  
2018+ Dodge Durango (non PPV)  
2018-2020 Dodge Durango PPV\*

\*2021+ Dodge Durango PPV has OEM Idle Protection  
Contact InterMotive for additional vehicle applications



### Introduction

The IdleLock for Dodge Durango will detect when the key fob leaves the vehicle, automatically lock the shifter in Park, and will allow the user to remove the key fob with the engine running. It also provides outputs to disable the weapon rack, trunk release, or other equipment when the vehicle is in IdleLock. It has an onboard relay which can be used to interrupt the gun rack release wire. The IDLE760 will keep the rack enabled for 10 seconds (configurable) after IdleLock is entered. Once this time has expired, the weapon rack release button will be disabled.

The trunk disable requires an external relay (not provided) and connects to a second output of the IDLE760. The trunk release will also stay enabled for 10 seconds after entering IdleLock.

### Installation Instructions

**Disconnect vehicle battery before proceeding with the installation.**



**WARNING**  
Disconnect the battery to  
prevent setting a check engine  
light.

It is the installer's responsibility to route and secure all wiring harnesses where they cannot be damaged by sharp objects, mechanical moving parts and high heat sources. Failure to do so could result in damage to the system or vehicle and create possible safety concerns for the operator and passengers.

It is important to avoid placing the module where it could encounter strong magnetic fields from high current cabling connected to motors, solenoids, etc. Also avoid radio frequency energy from antenna's or inverters next to the module. Finally, avoid high voltage spikes in vehicle wiring by always using diode clamped relays when installing upfitter circuits.

## IDLE760 Module

The Gateway module is located in the passengers side of the vehicle, find a suitable location to mount the IDLE module. Place the module in an area away from any external heat sources (engine heat, heater ducts, etc.). Do not mount the module until all post installation testing is complete and wire harnesses are routed and secure.

### Data Link Harness (6-pin connector on module)

The Durango has a "Gateway" module connected to the OBDII connector. The IDLE data link harness T's into both an 8-pin and 12-pin connector on this gateway module.



1. Locate the vehicle's Gateway module located on the left side of the glove box.
2. Remove the 12-pin and 8-pin connectors from the Gateway module and plug in the 12-pin and 8-pin connectors from the Intermotive IDLE760 Data Link harness. Plug the OEM 12-pin and 8-pin connectors into the mating connectors on the IDLE Data Link harness.
3. Plug the free end of the Data Link harness into the mating 6-pin connector on the IDLE760 module.

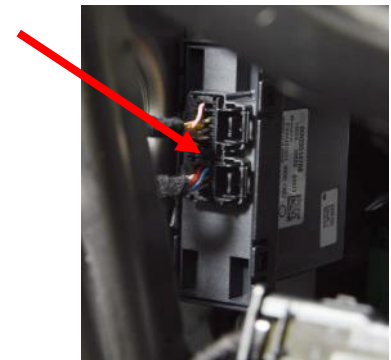

Durango gateway module with 8 & 12 pin connectors.

## IdleLock with Autosense Technology (L)

The IdleLock for Dodge Durango will automatically lock the shifter in Park and allows the officer to remove the key fob with the engine running. The IdleLock provides outputs to also disable the weapon rack, trunk release, or other equipment when the vehicle is in IdleLock. The system has an onboard relay which can be used to interrupt the gun rack release wire. The IdleLock will keep the rack enabled for 10 seconds (configurable) after IdleLock is entered. Once this time has expired, the weapon rack release button will be disabled.

The trunk disable requires an external relay (not provided) and connects to a second output of the IdleLock. The trunk release will also stay enabled for 10 seconds after entering IdleLock.

### Weapon Rack Disable Relay Connections

The IdleLock has an onboard Normally Closed pass-through relay that will open 10 seconds after Idlelock is engaged. The usual connection is to route the weapon rack release wire through the Idlelock's relay.

#### 4-Pin White Connector

- Pin #2 weapon Rack In, Purple wire on 4 pin IdleLock connector.
- Pin #4 weapon Rack Out, Blue wire on 4 pin IdleLock connector.

#### Trunk Release Disable Output

A discrete 12 volt output rated at 1/2A is intended to drive relay coils or other low current loads. This can be used to open a relay that interrupts the trunk release wire. The trunk cannot be opened when Idle Lock is active.

#### 12-Pin White Connector

- Pin #2 IdleLock Output, Brown wire on 12 pin IDLE connector (12V when IdleLock is active). To disable the Trunk, the Beige/Yellow wire pin 4 from the white BCM connector C6/F must be interrupted with a relay which is driven by the IdleLock output. Locate and cut the wire.

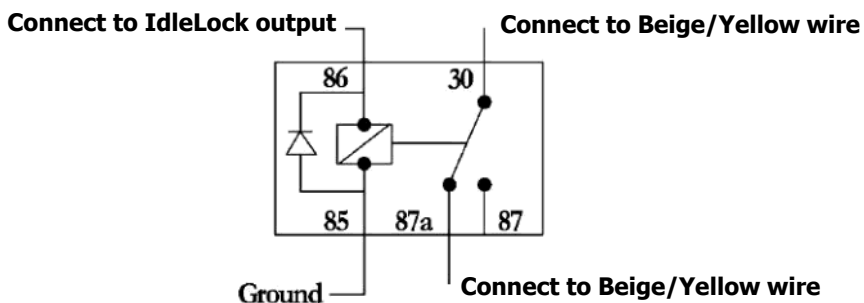

Wire Insertion Side:

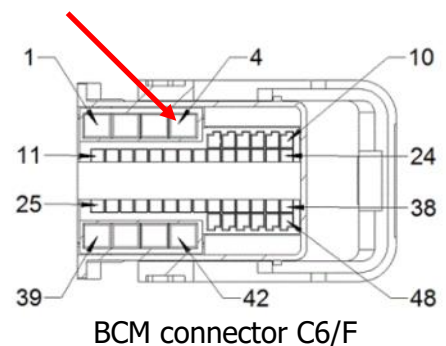

## **IdleLock Operating Instructions :**

### Auto Enable

Preconditions: Transmission in PARK and the Engine running.

- Every time the door is closed, IdleLock will check the location of the key fob. If the fob is present, nothing will happen. If the fob is NOT present, IdleLock will lock the shifter.
- If the door is left open, IdleLock will check the key fob location every 10 seconds. Once IdleLock determines the key fob has left, IdleLock will lock the shifter.

**Note:** IdleLock will stop checking once the key fob has left.

### Auto Disable

Preconditions: Transmission in PARK and the Engine running.

- Anytime the door is open, IdleLock will check the key fob location every second. Once IdleLock determines the key fob is present, IdleLock will unlock the shifter.

**Note:** IdleLock will stop checking once key fob is present.

- If the service brake is pressed, IdleLock will check the key fob for its location and if the key fob is present then IdleLock will unlock the shifter.
- If the seatbelt is buckled, IdleLock will check the key fob for its location and if the key fob is present then IdleLock will unlock the shifter.

## **IdleLock Post Installation Instructions**

Perform the following tests before mounting the module to allow viewing of the diagnostic LED's, if needed.

1. With the engine running, confirm you can shift out of Park.
2. Place transmission in Park, step away from the vehicle with the Key Fob in hand and close the driver door.
3. Place the Key Fob on the roof of the vehicle.
4. Open the driver door, get in the driver seat, and confirm the shifter is locked in Park.
5. Grab the key fob on top of the roof, place it in your pocket. At this point the shifter should unlock. Confirm by shifting out of Park.

**DO NOT PUT VEHICLE IN SERVICE IF IT DOES NOT PASS ALL OF THE ABOVE TESTS**

Contact InterMotive at 1-800-969-6080 for technical assistance.

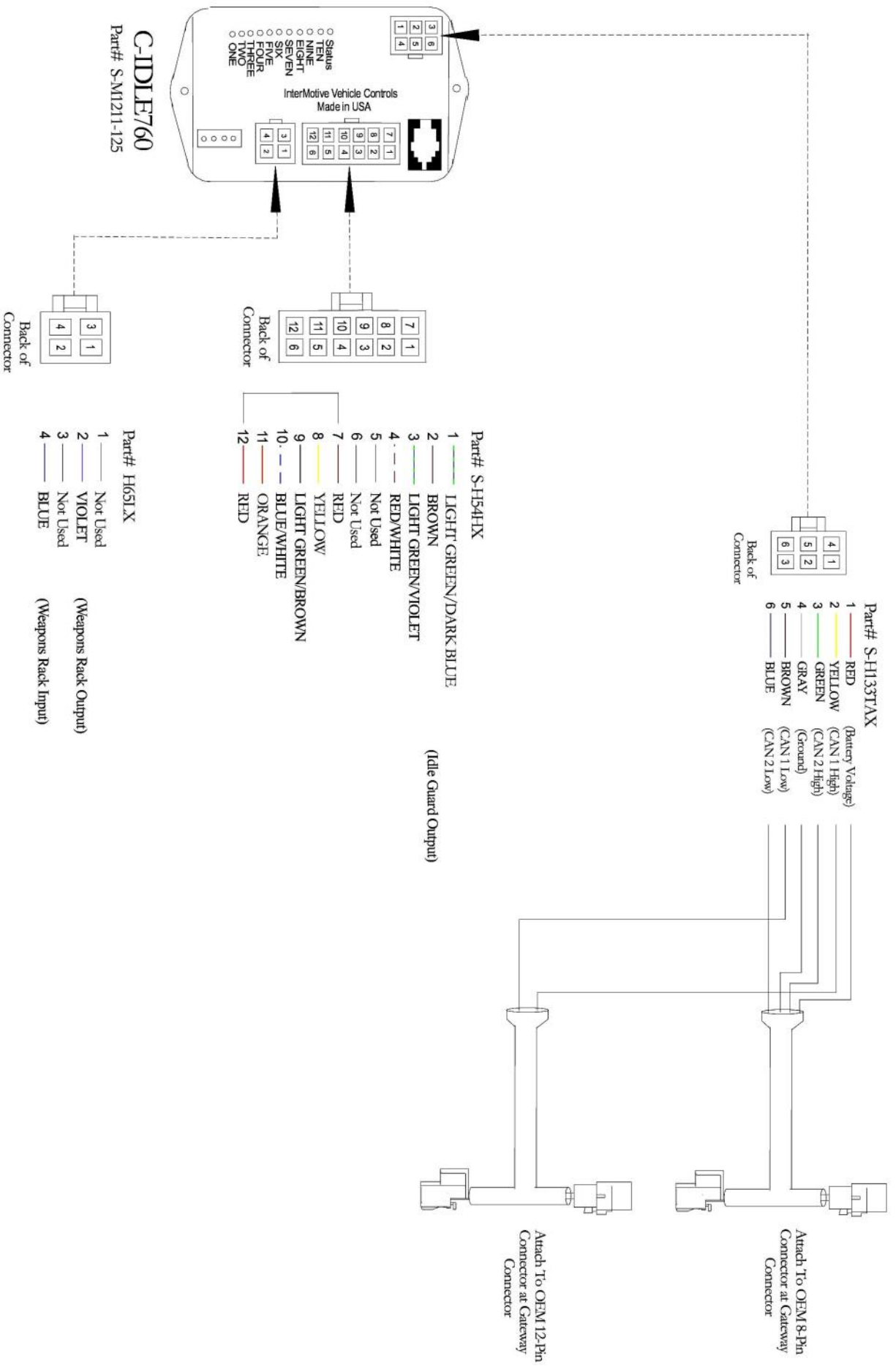

**Submit product registration at [www.intermotive.net](http://www.intermotive.net)**  
 If the C-IDLE760 fails any step in the System Operation Test, review the installation instructions and check all connections.  
 If necessary, call Intermotive Technical Support at (530) 823-1048