

C-EVO755-A
2023 Ram ProMaster (Without Remote Start)
Patent Pending

*For Chassis without remote start and OEM hood switch

Contact InterMotive for specific engine applications.

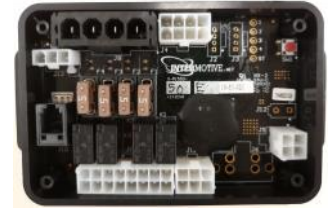

System Overview

The C-EVO755-A is an engine start/stop system designed for the RAM ProMaster chassis. It will automatically start and stop the vehicle's engine (when enabled) to charge the OEM 12V battery and/or an auxiliary battery system. It allows unattended (key out) operation for enhanced security. The product has several field programmable parameters which can be modified to user specifications.

C-EVO755-A interfaces with the vehicle through the use of "plug and play" connectors that plug directly into the factory OEM connectors. This method of installation reduces the installation time and improves connection reliability.

The module provides internal safeguards as well as functional preconditions to ensure the safe operation of the vehicle. In addition, there are diagnostic functions that allow for rapid troubleshooting.

IMPORTANT—READ BEFORE INSTALLATION

It is the installer's responsibility to route and secure all wiring harnesses where they cannot be damaged by sharp objects, mechanical moving parts and high heat sources. Failure to do so could result in damage to the system or vehicle and create possible safety concerns for the operator and passengers. Avoid placing the module where it could encounter strong magnetic fields from high current cabling connected to motors, solenoids, etc. Avoid radio frequency energy from antennas or inverters next to the module. Avoid high voltage spikes in vehicle wiring by always using diode clamped relays when installing upfitter circuits.

CAUTION

All electronic products are susceptible to damage from Electrostatic Discharge or ESD. Ground yourself before handling or working with the module and harnessing by first touching chassis ground, such as the barrel of the cigarette lighter.



Installation Instructions

Disconnect vehicle battery before proceeding with the installation.



WARNING
Disconnect the battery to
prevent setting a check engine
light.

EVO755 Module

Remove the lower dash panel below the steering column and find a suitable location to mount the module. Locate the module in an area away from excessive heat sources (engine, heater ducts, etc.). Ensure when routing harnesses that the tilt steering column does not contact them in the full down position. When installing the harnesses, leave several inches of take-out so the module can be removed if necessary. Do not mount module until all wire harnesses are routed and secure. The last step of the installation is to mount the module.

Data Link Harness - 6 pin connector

The ProMaster has an OEM Gateway module located behind the glovebox. Follow the steps below to access it:

1. Open the glovebox door.
2. Locate the 2 release tabs on the inside of the glovebox (one on the left and one on the right) and drop the door into the full down position.
3. Locate the two fasteners securing the glovebox assembly to the vehicle and remove them.
4. Locate the 4 fasteners on the outside of the glovebox assembly and remove them.
5. Remove the glove box assembly.
6. The Gateway module is located behind the glove box assembly as shown in the picture.
7. Remove the 12-pin and 8-pin connectors from the Gateway module and plug in the 12-pin and 8-pin connectors from the InterMotive C-EVO755-A Data Link harness. Plug the OEM 12-pin and 8-pin connectors into the mating connectors on the C-EVO755-A Data Link harness.
8. Plug the free end of the 6-pin Data Link harness into the mating 6-pin connector on the 4 foot extension harness (S-H94AX-04). Plug the other end of the extension harness into the mating 6-pin connector on the C-EVO755-A module.

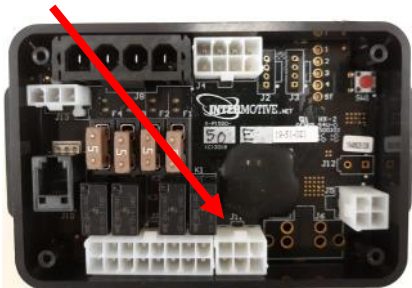

Ignition Switch Installation

The ignition switch must be accessed in order to connect the C-EVO755-A ignition harness.

1. Remove the lower steering column opening cover (trim panel below steering wheel). Three screws will need to be removed.



2. Remove the four screws attaching the lower shroud to the upper shroud.

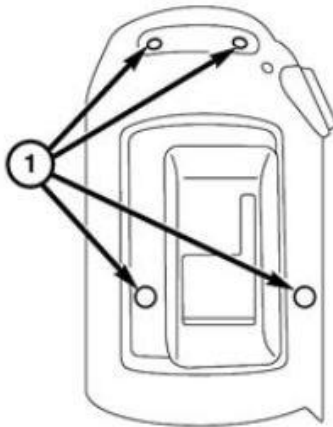

Ignition Switch Installation (Continued)

- Unclip the upper and lower shrouds from one another by applying hand pressure along the seams where the shrouds connect on the sides. Drop the lower shroud down to access the back of the Push-to-Start button.



- Remove the OEM connector from the rear of the Push-to-Start button and plug it into the mating connector on the InterMotive harness. Plug the male connector from the InterMotive harness into the mating connector at the rear of the Push-to-Start button.

Service Brake Installation

- Locate the Service Brake switch above the Service Brake and remove the connector from the switch.
- Plug the mating connector from the C-EVO755-A harness into the OEM switch.
- Plug the OEM connector into the mating connector from the C-EVO755-A harness.

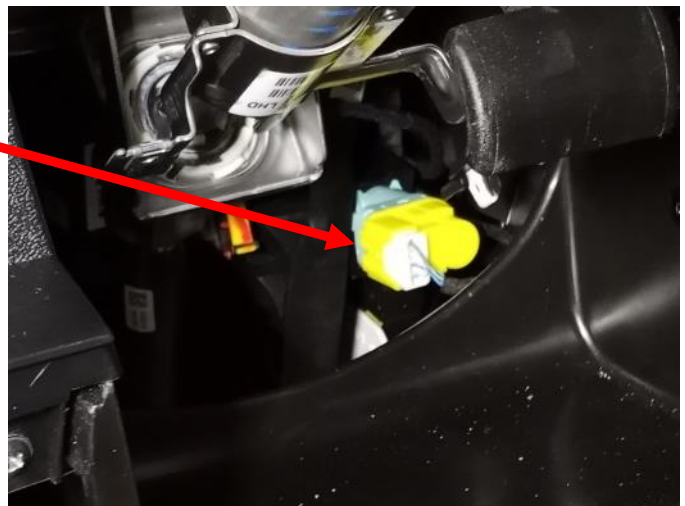

Hood Switch Installation:

The OEM hood latch will need the 840-00312 Hood Switch Assembly installed.

1. Locate the hood latch under the hood.
2. Remove the 3 nuts attaching the latch to the body.
3. Remove the latch and disconnect the hood release cable and separate it from the latch.
4. Install the hood switch harness (840-00312) onto the hood latch using the provided hardware.

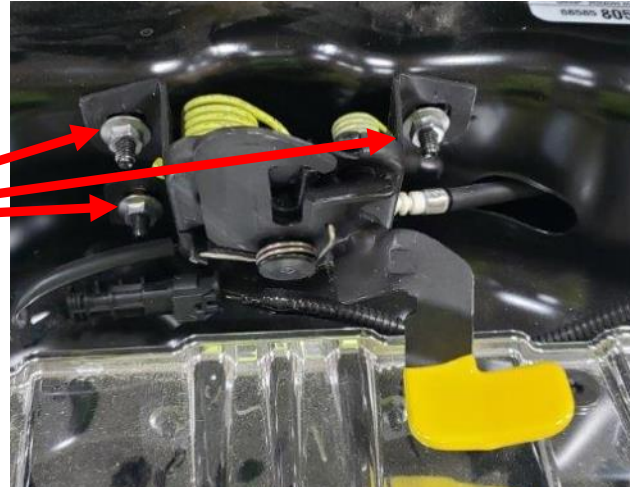

5. Slide the wires through the opening in the corner and position the switch as shown.



6. After the switch is properly positioned, fasten it down with the bolt, washer, and lock-nut.

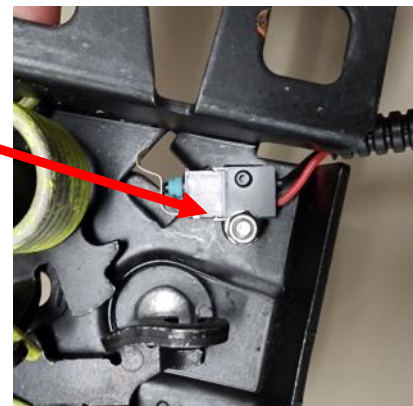

7. Zip-tie the cable to the hood latch shown in the picture.

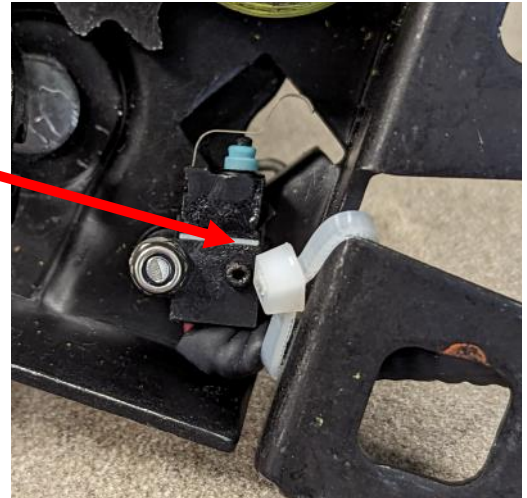

8. Attach the hood release cable onto the hood latch.

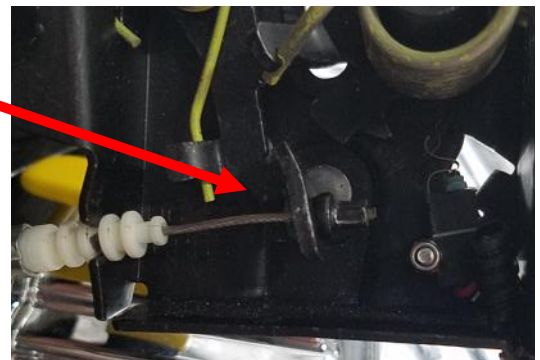

9. Attach and tighten the 3 nuts.

10. Plug the mating connector of the InterMotive hood switch harness (Part #840-00305) into the installed hood switch connector.



11. Locate the pass-through hole on the firewall on the driver's side of the vehicle (see photo).

12. Remove the plug and route the hood switch harness through the hole.

13. Plug the 2-pin Molex connector into the mating connector on the C-EVO755-A main harness.



C-EVO755-A Module

1. Remove the four screws from the lower center panel below the shifter. It will be necessary to remove the cupholder to access the lower two screws.
2. Remove the lower center panel by pulling toward the rear of the vehicle.



3. Mount the module in the location shown in the photo with screws and/or double-sided tape.



Monitor Mode Button Installation

A push button with an integral LED is provided in the kit (Part #S-H84KX).

1. Drill a 16mm (0.630") hole in the desired mounting location. A recommended location for the button is in the recessed area to the left of the steering wheel (see photo).
2. Remove the lock nut from the Monitor Mode button and route the harness through the hole. Mount the button in the hole.
3. Slide the lock nut onto the harness and secure it onto the back of the Monitor Mode button.
4. Plug in the 4-pin black connector of the button harness into the mating connector on the C-EVO755-A main harness.

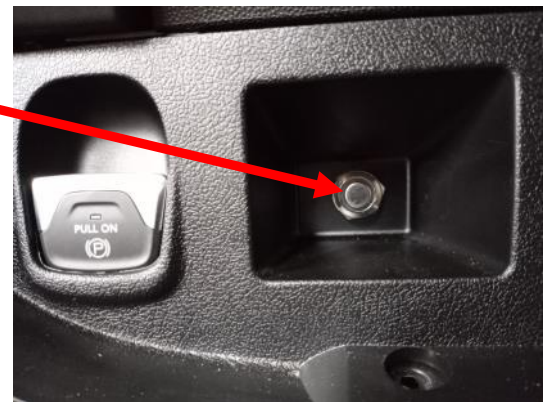

Key Fob Box

A spare key fob will need to be modified and inserted into the provided enclosure to allow the C-EVO755-A system to work with the main key fob outside of the vehicle.



1. Remove the key from the fob.



2. Open the key fob using a small flat head screwdriver.



3. Remove the battery from the key fob.



4. Remove the RAM overlay from the back of the key fob.



Key Fob Box (continued)

5. Place the bottom half of the key fob in the key fob jig (Part #432-00008) as shown in the picture.



6. Flip the key fob and jig upside down and drill a hole through the back of the key fob using a 0.5" drill bit.



7. Place the battery board in the key fob as shown.



8. Snap both halves of the key fob back together. Ensure that the connector on the opposite side of the battery board is centered in the middle of the hole.



9. Place the key fob in the bottom half of the key box provided with the C-EVO755-A.



Key Fob Box (continued)

7. Plug the 2-pin white connector into the battery board and route the harness toward the hole in the side of the box. Place the rubber grommet in the hole as shown.



8. Place the top portion of the box on top and secure it with the four included screws. Plug the 3-pin connector into the mating connector on the main harness.



9. Mount the module on the lower center panel with double-sided tape as shown.



Installation continued

Verify that the following connections and installations have been made:

1. The Data Link Connector and extender harnesses have been installed.
2. The key has been removed from the fob, the fob has the battery board installed and the key fob box has been mounted. The 3-Pin Molex connector has been plugged into the main harness.
3. The Ignition Switch connector has been plugged into the ignition switch and the C-EVO755-A main harness as described on Page 4.
4. The lower center panel has been removed and the C-EVO755-A module has been mounted as suggested on Page 7.
5. The Monitor Mode button has been mounted and has been plugged into the C-EVO755-A main harness.

Make the following connections from the C-EVO755-A main harness to the C-EVO755-A module:

1. Plug the 4-Pin connector into J8 of the C-EVO755-A module.
2. Plug the 4-Pin Molex connector into J5 of the C-EVO755-A module.
3. Plug the 8-Pin Molex connector into J4 of the C-EVO755-A module.
4. Plug the 16-Pin Molex connector into J7 of the C-EVO755-A module.
5. Plug the 3-Pin Molex connector into J13 of the C-EVO755-A module.
6. Plug the 4-pin LIN connector into J2 of the C-EVO755-A module.

Make the following connections to the C-EVO755-A harness as required for the application:

1. If module is configured to monitor auxiliary battery voltage, connect the 2-pin Deutsch connector from the auxiliary battery system to the connector on the C-EVO755-A main harness. **Note:** The Red wire senses the auxiliary battery system voltage. The green wire is an output to indicate when Fast Idle RPM is above configurable value.
2. If module is configured to receive 12V start input, connect the Yellow wire from J4 Pin 7 to an external device providing a 12V output.

Reconnect vehicle battery

With the key in run, plug the free end of the C-EVO755-A Data Link harness into J11 of the C-EVO755-A module.

Once all connections have been made, installation is complete. Before re-installing panels on the vehicle, be sure to conduct all post installation checks and verify correct operation of the module.

MODULE OPERATION

When activated, the C-EVO755-A module will start a vehicle under certain conditions allowing the alternator(s) to keep both the OEM and auxiliary batteries charged properly.

The module initiates the auto-start functions based on any of these three events:

1. The OEM battery voltage is monitored directly on the module, and if it falls below a preset point, the module will start the engine. While the engine is running, the module continues to monitor the battery voltage, and when it increases to a preset level, a timer (configurable) is started. The engine continues to run until the time interval has elapsed at which point the module will stop the engine.
2. The auxiliary battery voltage is monitored directly on the module, and if it falls below a preset point, the module will start the engine. While engine is running, the module continues to monitor the battery voltage, and when it increases to a preset level, the module will stop the engine.
3. If configured to do so, C-EVO755-A can work with a Battery Management System and receive a 12V start trigger. When the 12V start trigger is received, the module will start the engine. When this 12V trigger is removed, the module will stop the engine.

NOTE: The module is configured to monitor EITHER event 2 or event 3, but NOT BOTH. Both OEM and auxiliary battery sources are required to be fully charged in order to stop the engine. "Fully charged" for event 2 means that the module has measured auxiliary battery voltage to be at or above preset level. "Fully charged" for event 3 means that the 12V trigger has been removed.

Fast Idle:

After an auto-start, the engine is commanded to run at a higher RPM (preset) to facilitate optimal charging time. The engine speed is typically set to 1600 RPM (default) but can be modified within limits. As long as the engine coolant temperature (ECT) is within its safe operating range (-10° C —110° C or 14° F—230° F), the vehicle can run at a Fast Idle speed.

Fast Idle is an independent feature controlled by certain preconditions which are common to the auto-start/stop feature. The following are required for the Fast Idle to be enabled:

- Vehicle in Park
- Vehicle engine speed between 400 RPM and 2800 RPM
- ECT as stated above

OverRev Output:

The module has an output which goes active whenever the engine RPM is above a programmed value. The high RPM limit is set to 3700 RPM by default, but for testing purposes can be reduced to 1700 RPM (see Page 15 under diagnostics).

1. With the module in normal mode, start the engine, apply the accelerator to increase RPM beyond the high limit, and verify the appropriate response from the auxiliary battery system.
2. Conversely, verify appropriate response when engine RPM drops back below high limit.

VIN Scroll:

Upon a hard boot, the C-EVO755-A module receives VIN information from the vehicle in order to verify that the module is connected to the vehicle that it is designed for. If power is provided to the module (data link harness is plugged in) without the key in "RUN," the module will VIN scroll (LEDs blink in ascending then descending order) for a few seconds before going to sleep. Pressing the ignition button to turn the ignition on will allow the module to verify VIN information and operate as intended.

Monitor Mode:

For the C-EVO755-A to control engine start/stop, it must first be in "Monitor Mode." If preconditions below are met, this mode can be entered by pushing and holding the Monitor Mode button for a preset amount of time, or by pushing the FOB "Lock" button 3 times. Preconditions for entering Monitor Mode are the following:

- Vehicle in Park
- Service Brake released
- Parking Brake applied
- Hood Closed
- Fuel Level above configured value (default 25% tank)
- Ignition on, engine off (if using the push button to enter Monitor Mode)
- ECT is below "shutdown ECT" configured value

If preconditions are met and Monitor Mode is entered, the Monitor Mode button LED turns ON as a visual indication. If Monitor Mode is entered using the key fob, the car horn will chirp twice and the lights will blink twice as confirmation that Monitor Mode was successfully activated. As long as Monitor Mode is active, the LED remains ON continuously. The ignition can be set to off after entering Monitor Mode.

Upon entering Monitor Mode with the FOB, the instrument cluster will turn on, a 10-second timer will start, and the module will monitor the OEM and auxiliary battery voltages. If both battery voltages are above their respective low battery thresholds and the 10-second timer expires, the system will turn the dash lights off and continue to monitor the battery voltages with the dash lights off. Once the battery voltages drop below their thresholds, the system will turn on the dash lights and start/Fast Idle the engine as normal.

There is a configurable engine-run timeout that will start each time the system auto-starts. The engine will run until both the OEM and auxiliary batteries are fully charged, or until the engine timeout timer expires, whichever comes first.

A continuous LED on the Monitor Mode button indicates normal operation. If the LED is blinking, either an error has occurred or an unwanted state has been entered. Four states are defined:

- Engine failed to start after 3 tries
- Engine failed to stop after 3 tries
- Engine prematurely stopped
- Service brake is applied while in Monitor Mode

The fourth state is an anti-theft precaution. In this case, auto-start/stop is again disabled for a period of time (configurable) before automatically returning to normal Monitor Mode operation. In addition to the Monitor Mode button LED blinking, each of these states will also cause a *module* LED to light up as a way to visually identify the state. Module LEDs 1-4 are assigned to the above states respectively. Error states can be exited by pressing the vehicle's Push-to-Start button. For each of these cases, auto-start/stop function is disabled until Monitor Mode is reset (exiting then reentering).

Exiting Monitor Mode is accomplished either by pushing and holding the Monitor Mode button or by pressing the 2 FOB "unlock" buttons alternately (3 pushes total). If the engine is running, the C-EVO755-A will shut it OFF and then exit Monitor Mode (Monitor Mode button LED turns OFF).

Battery Forced Charge:

An additional feature in Monitor Mode allows the user to start the engine and Fast Idle in order to "top-off" the charge on the auxiliary battery. If the module is in Monitor Mode, the user can press the Monitor Mode button three times within a 3-second window. The engine will then start and go to Fast Idle. Once the auxiliary battery system is fully charged, the C-EVO755-A will shut off the engine.

Note that Fast Idle charging will also terminate if the engine run timer expires, or the fuel level drops below the configured low-fuel threshold level.

Configuration:

The operational aspects of the C-EVO755-A are defined/controlled with the use of several parameters. Each has a preset value stored in non-volatile memory. Any of these values can be modified in the field with the use of an InterMotive download cable and a laptop running a terminal emulator application. This laptop/download cable combination is also used to update firmware in the field. Contact InterMotive to order a download cable (S-H37AX) if required.

The following parameters are available for modification:

- **OEM low voltage trip point** - Engine auto-starts when OEM battery falls to this level. Default value is 11.8V. Range is 8V to 15V.
- **OEM charge restore point** - When voltage level is reached, module will start an extended timer. Default value is 13.5V. Range is low limit to 15V.
- **Extended charge time** - How long engine continues to run after OEM restore point is reached. Default value is 1200 seconds. Range is between 10 and 3600 seconds.
- **Fast Idle engine speed** - Default value is 1600 RPM. Range is between 950 RPM and 2000 RPM.
- **Engine OverRev** - Special output goes active when this value is exceeded. Default value is 3700 RPM. Range is between 2000 and 4500 RPM.
- **Monitor Mode lockdown time** - When in Monitor Mode, a temporary lockout occurs if service brake is applied, disabling auto-start/stop. This lockdown time setting determines how long before the module reverts back to normal Monitor Mode with auto-start/stop functions restored. The Default value is set at 300 seconds. Range is between 10 and 600 seconds.
- **Push Button Latency** - Button must be held at least this long before it takes effect. Default value is 2 seconds. Range is between 2 and 10 seconds.
- **Shutdown ECT** - Maximum coolant temperature beyond which the engine will shut down (if already running) and the module will exit monitor mode. Default value is 110° C (230° F).
- **Maximum ECT** - Maximum coolant temperature beyond which Fast Idle ceases to operate. Default value is 104° C (219° F). Range is between 65° C and 110° C (149° F to 230° F).
- **Minimum ECT** - Coolant temperature must be at least this value before Fast Idle will operate. Default value is -10° C (14° F). Range is -10° C to 15° C (14° F — 59° F).
- **Toggle Crank feature ON/OFF** - If enabled, the OverRev output will be active during crank.
- **Auxiliary Battery low voltage trip point** - Engine auto-starts when auxiliary battery falls to this level. Default value is 49.9V. Range is between 40V and 60V.
- **Auxiliary Battery charge restore point** - When voltage level is reached, module will stop the engine. Default value is 57V. Range is between low limit (as set above) and 60V.
- **Low Fuel Level threshold value** - If fuel level on vehicle is below this value, system will not enter monitor mode. Default value is 25% of full tank. Range is between 0% and 100%.
- **Engine-Run Timeout Value** - Maximum allowable time engine will run on a single auto-start event. Default time is 60 minutes. Range is between 50 and 120 minutes.

Using a laptop and download cable, a configuration menu is available and can be used to make changes to any of the previous parameters. Contact InterMotive for further instructions on how to set this up.

Diagnostics

The C-EVO755-A module is equipped with diagnostic features which can facilitate troubleshooting. Diagnostic functions use module LEDs as well as the red test button to assist the user.

There are four sets of red LEDs tied to fuses F1 - F4. When lit, they indicate the adjacent fuse is blown. Five other LEDs labeled 1 - 4 and "ST" are used to display status information depending on the diagnostic page that is selected. The "ST" LED will "blink out" the current diagnostic page. For example, it will blink once if on page 1, then delay and blink once again. If on page 2, it will blink twice then delay, then twice again, etc. There are 7 pages currently defined. If the "ST" LED is OFF, the other 4 LEDs will identify a Monitor Mode error if one should occur.

Pages are sequentially selected by pushing the red Test button; the next page's data is displayed after each push. One can proceed either forward (1->7) with Park Brake applied or reverse (7->1) with Park Brake released.

Pages 1-6 will display status information as follows:

	<u>PAGE1 Module Inputs 1-4</u>	<u>PAGE2 Module Inputs 5-7</u>	<u>PAGE3 Outputs</u>
LED1	Monitor Mode Button	Unused	LCO1
LED2	Hood Switch Valid	Aux Battery Low Request	LCO2
LED3	Hood Closed	Unused	LCO3
LED4	Start button pressed	Monitor Mode LED	LCO4
	<u>PAGE4 Relay 1-4</u>	<u>PAGE5 Internal Use Only</u>	<u>PAGE6 Internal Use Only</u>
LED1	Relay1	—	—
LED2	Relay2	—	—
LED3	Relay3	—	—
LED4	Relay4	—	—

Page 7 is a special mode that modifies some operational parameters to help make testing the module easier. These changes are only temporary, and the parameter values return to normal the next time the module is powered up:

- Extended charge time is set to 15 seconds.
- Engine OverRev value set to 1700 RPM.
- Monitor Mode lockdown time is set to 10 sec (after pressing Service Brake while in Monitor Mode).
- Engine-Run Timeout value is set to 1 minute.

Post Installation Checks

With all connections properly made to the module, ignition switch, hood latch, and auxiliary battery system, verify that engine will start/stop using the OEM key and the vehicle drives properly.

Monitor Mode:

Begin with vehicle stopped, in PARK, ignition on and engine off, hood closed, parking brake applied, and service brake released.

1. Push and hold the Monitor Mode button for at least 2 seconds (depending on the button latency setting). The button LED will light up indicating the vehicle is now in Monitor Mode. The module is now monitoring both the OEM battery voltage as well as either the auxiliary battery voltage or the 12V start input.
2. Push and hold the Monitor Mode button again and verify LED turns OFF, taking module out of Monitor Mode.
3. Apply the Parking Brake and put the vehicle in some gear other than PARK. Push and hold the Monitor Mode button again and verify module **does not** go into Monitor Mode. Release button.

Post Installation Checks (continued)

4. Push and hold the Monitor Mode button and verify LED turns OFF, taking module out of Monitor Mode.
5. Put the vehicle back into PARK, apply and hold the service brake, and push and hold the Monitor Mode button again to verify the module does not go into Monitor Mode. Release button and service brake.
6. Open the hood and push and hold the Monitor Mode button again to verify the module **does not** go into Monitor Mode. Release button.
7. Close the hood and repeat STEP 1 with the ignition on/engine off. Module should go into Monitor Mode.
8. Push ignition button to OFF position.
9. Turn ON some vehicle loads that can run with the ignition off such as the headlights to draw down the OEM battery. When the battery voltage eventually falls to the preset low threshold, verify engine automatically starts.
10. With the engine running, verify Fast Idle is enabled after a couple seconds. The engine RPM should increase to the preset point and stabilize until the module stops the engine.
11. Verify engine runs for the appropriate amount of time and then stops automatically. **NOTE:** For testing purposes this run time can be reduced with a diagnostic feature as explained on Page 15.
12. Repeat STEP 9 to get the engine running again. Once engine is running at Fast Idle, apply the service brake and verify the following:
 - Fast Idle is disabled
 - Engine stops
 - Monitor Mode button LED starts blinking
13. Verify Monitor Mode button LED continues to blink for some time and then returns to continuous ON status. **NOTE:** While blinking, the auto-start/stop feature is disabled.
14. With the engine OFF, draw down the auxiliary battery or cause an external auxiliary battery management system to send the 12V engine start request signal.
 - If the module is configured to monitor auxiliary battery voltage directly, verify the engine starts and runs at Fast Idle until the auxiliary battery voltage reaches the preset level.
 - If the module is configured to receive a 12V request signal from a battery management system, verify the engine starts and runs at Fast Idle while the signal is active (12V) and then shuts OFF when the signal goes inactive (0V).
15. Push and hold the Monitor Mode button again and verify LED turns OFF. In this state, auto-start/stop is deactivated. Verify this by drawing down the OEM battery (see STEP 9) and observing the engine will not auto-start.
16. Verify alternate activation of Monitor Mode by pressing the Fob "lock" button 3 times.
17. Verify alternate deactivation of Monitor Mode by pressing the Fob "unlock" button 3 times, alternating between the two unlock buttons with each press.

If the module fails any step in the checklist, review the installation instructions and check all connections. If necessary, call InterMotive Technical Support at (530) 823-1048.

Submit product registration at www.intermotive.net

C-EV0755-A

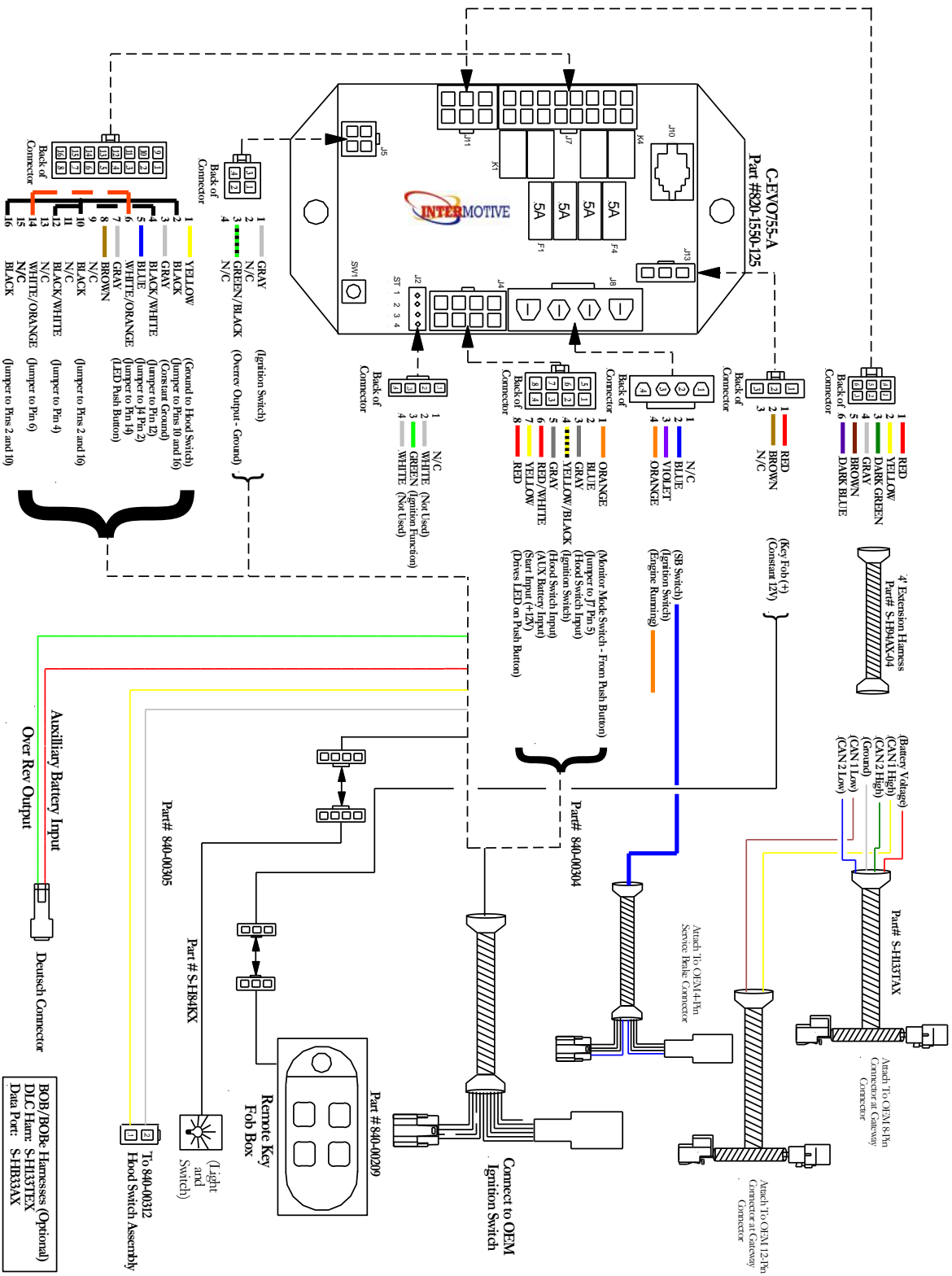

If the C-EV0755-A fails any step in the post installation test, review the installation instructions and check all connections. If necessary, call InterMotive Technical Support at (530) 823-1048

C-EV0755-A Parts List



820-1550-125

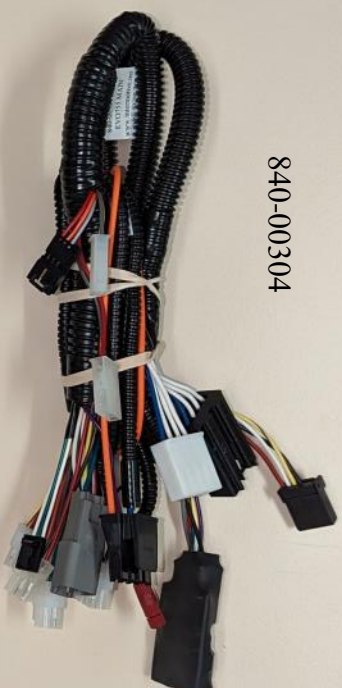

840-00304



840-00209



840-00305



S-H84KX



S-H94AX-04



S-H133TAX



840-00312