

Instructions



B-ILISP511-C Shift Interlock **2021 - 2026 Ford E-Series**

Contact InterMotive for additional vehicle applications

System Overview

The ILISP511-C is a wheelchair lift safety interlock which will work with the key on or key off. It will enable the lift when certain vehicle safety conditions are met, and will lock the transmission shifter in Park when the lift is in use (not stowed). Optional Plug & Play harnesses are available for most applications which makes the installation fast and easy.

Installation Instructions

Disconnect vehicle battery before proceeding with installation.



WARNING
Disconnect the battery to
prevent setting a check engine
light.

IMPORTANT — READ BEFORE INSTALLATION

It is the installer's responsibility to route and secure all wiring harnesses where they cannot be damaged by sharp objects, mechanical moving parts and high heat sources. Failure to do so could result in damage to the system or vehicle and create possible safety concerns for the operator and passengers.

Avoid placing the module where it could encounter strong magnetic fields from high current cabling connected to motors, solenoids, etc. Avoid radio frequency energy from antennas or inverters next to the module. Avoid high voltage spikes in vehicle wiring by always using diode clamped relays and solenoids when installing upfitter circuits.

CAUTION

All electronic products are susceptible to damage from Electrostatic Discharge or ESD. Ground yourself before handling or working with the module and harnessing by first touching chassis ground, such as the barrel of the cigarette lighter.



B-ILISP511-C Module

Remove the lower dash panel below the steering column area and find a suitable location to mount the module so that the Diagnostic LED's can be viewed with the lower dash panel removed. Locate the module in an area away from any high heat sources (engine heat, heater ducts, etc.). Do not actually mount the module until all wire harnesses are routed and secure. The last step of the installation is to mount the module.

Instructions

Gateway Plug and Play Harness (4-pin connector)

1. Locate the vehicles Gateway Module. It will be mounted below the lower left dash panel.
2. Remove the harness behind the Gateway module by pressing the locking tab and pulling outward.
3. Plug the Female side of the InterMotive Gateway Harness into the back of the Gateway module. Ensure the connection is fully seated and secured by the locking tab.
4. Plug the Male side of the InterMotive Data Link Harness into the Gateway harness.
5. Secure the B-ILISP511-C Gateway harness so that it does not hang below the lower dash panel.
6. Plug the free end of the Data Link harness into the mating 4-pin connector on the B-ILISP511-C module.

Gateway Module →

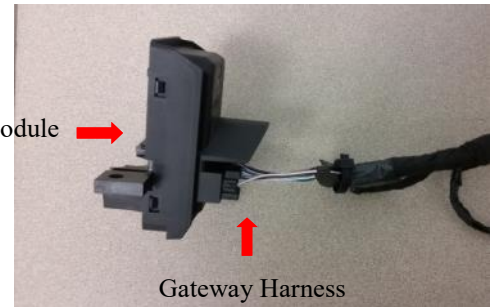

↑
Gateway Harness



LED Display Panel Mounting - Black 4-pin connector

Locate a suitable position on the dashboard, within view of the driver to mount the LED Display Panel. Ensure there is open space behind the dash where the panel is mounted. The harness is 40" in length, which is the maximum distance the display can be from the module.

1. Drill a 5/8" hole in the dash where the center of the display will be located.
2. Attach the Black 4-pin connector of the LED display panel harness to the module.
3. Run the other end of the harness under the dash and out through the 5/8" hole.
4. Attach the end to the LED Display Panel.
5. Ensure the panel is level and secure using supplied screws.

Instructions

Control Inputs/Outputs - 8-pin connector

Refer to the B-ILISP511-C CAD drawing as reference when reading these instructions.

Lengthen the following wires, using solder and heat shrink or tape.

Orange or Green – This *Lift Enable/Vehicle Secure* output provides 12V@8 amps when it is safe to operate the lift. Connect this output to the lift's "enable" signal.

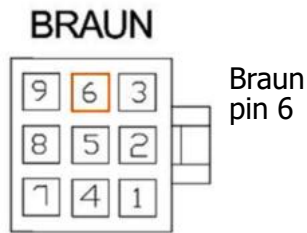

Drawings are looking into the backside of the connectors where the wires exit the connector.

Note: connecting the Lift Enable/Vehicle Secure Orange wire to the wrong lift pin can damage the interlock.

If in doubt, try connecting a fused (8A) source 12V signal to the pin in question to ensure it enables the lift and does not draw too much current, such as when connecting to a ground pin. If the lift draws more than 8 amps on it's enable signal, a control relay will need to be installed.

Instructions

Shift Lock Harness

1. Remove the upper and lower steering column covers by removing the 3 screws in the lower column cover.



2. Locate the Shift Lock (4-pin) harness.
3. Unplug the Shift Lock connector.
4. Plug the OEM Shift Lock connector into the mating connector on the B-ILISP511-C harness.
5. Plug the 4-pin connector on the B-ILISP511-C harness into the mating connector on the OEM Shift Lock harness.

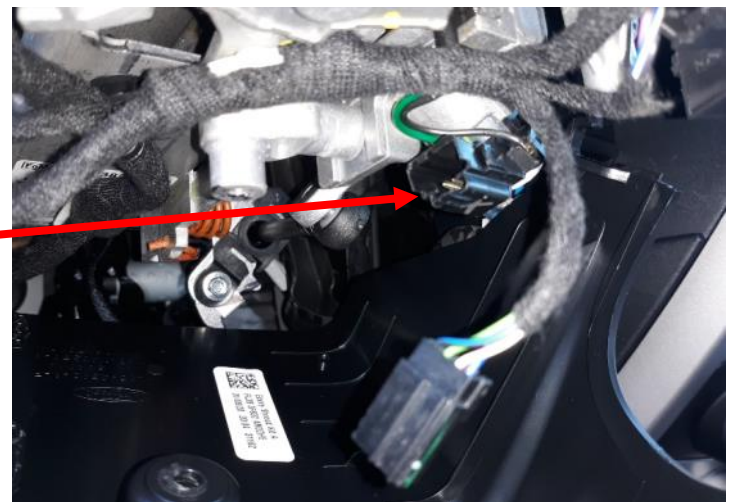

Connect the 8 pin connector to the module

B-ILISP511-C Module

Ensure all the harnesses are properly connected and routed, and are not hanging below the dash area. Mount the B-ILISP511-C module as described on page one and secure using screws or doubled sided tape.

Reconnect vehicle battery

Instructions

Post Installation / Check List

B-ILISP511-C

The following checks must be made after installation of the system, to ensure correct and safe operation of the lift. If any of the checks do not pass, do not deliver the vehicle. Recheck all connections as per the installation instructions.

Key On function:

1. The system will wake up when the fob or pendant deploy buttons are pushed.
2. With the module awake and the vehicle in Park, the (P) and Shift Lock LEDs will be illuminated.
3. When the Park Brake is applied, the (PB) LED will be illuminated.
4. When the Lift is deployed, the Lift Deployed LED will be illuminated.
5. With the Park Brake applied, the PB, P, Shift Lock, and Vehicle Secure LED's will be illuminated, and the lift will be operational (enabled).



Vehicle Secure/Lift Enable, Lift Deployed, Park Brake, Park, Shift Lock

Key Off function: (if optional Park Brake input supplied)

- Vehicle must be in Park before turning key off.
- With the vehicle in Park and the Park Brake applied, the (P), (PB), and Vehicle Secure LED's will be on.
- When the lift starts to deploy, the Shift Lock and Lift Deployed LEDs will illuminate.

When the lift is stowed and ignition power is not present for 5 minutes, the system will enter a low current "sleep" mode of operation. To wake from "sleep" mode, turn the ignition on (key on) or press the lift deploy button on the pendant or fob (may have to be depressed for a second or two to wake the system). All display LEDs will illuminate for approximately 2 seconds as a "prove out". The backlit LEDs will remain on as long as the module is awake.

Note: If the vehicle has Daytime Running Lights they will be activated when the Lift Door is open and/or the Park Brake is on and the Ignition Key is on.

Note: Do not leave the lift deployed when the vehicle is not in use. This will cause a current draw on the vehicle's electrical system and could result in a dead battery.

Instructions

LEAVE IN VEHICLE

Operating Instructions - Shift Interlock

B-ILISP511-C (2021 - 2026 Ford E-Series)

System Operation

The B-ILISP511-C is a wheel chair lift safety interlock which will operate with the key on or key off. It will enable the lift when certain vehicle safety conditions are met, and will lock the transmission shifter in Park when the wheelchair lift is in use (not stowed). The B-ILISP511-C prevents the vehicle from being shifted out of park if the lift is not stowed.

Key On function:

1. When the vehicle is in "Park" the (P) LED will be ON.
2. When the Park Brake is applied, the (PB) LED will be ON.
3. When the Lift is deployed, the Lift Deployed LED will be ON.
4. With the vehicle in Park and either the Park Brake applied or the lift deployed, the Shift Lock LED will be ON and the transmission cannot be shifted out of Park.
5. With the vehicle in Park, Park Brake applied, and the fob or pendant deploy buttons pushed, the Vehicle Secure LED will be ON and the lift will be operational. **All LEDs will be illuminated on the display panel.**

Key Off function: (if discrete Park Brake supplied)

- Vehicle must be in Park before turning key off.
- With the vehicle in Park, the (P) LED and Shift Lock LED will be ON.
- With the Park Brake applied and the lift deployed, all LEDs will be ON, and the lift will be operational.

All display LEDs will turn ON for approximately 2 seconds as a "prove out". The backlit LEDs remain ON as long as the module is awake.

Sleep Mode:

When the lift is stowed and ignition power is not present for 5 minutes, the system will enter a low current "sleep" mode of operation. To wake from "sleep" mode, turn the ignition on (key on) or press the lift deploy button on the pendant or fob (may have to be depressed for a second or two to wake the system). All display LEDs will illuminate for approximately 2 seconds as a "prove out". The backlit LEDs will remain on as long as the module is awake.

B-ILISP511-CD Blunt Cut Harness

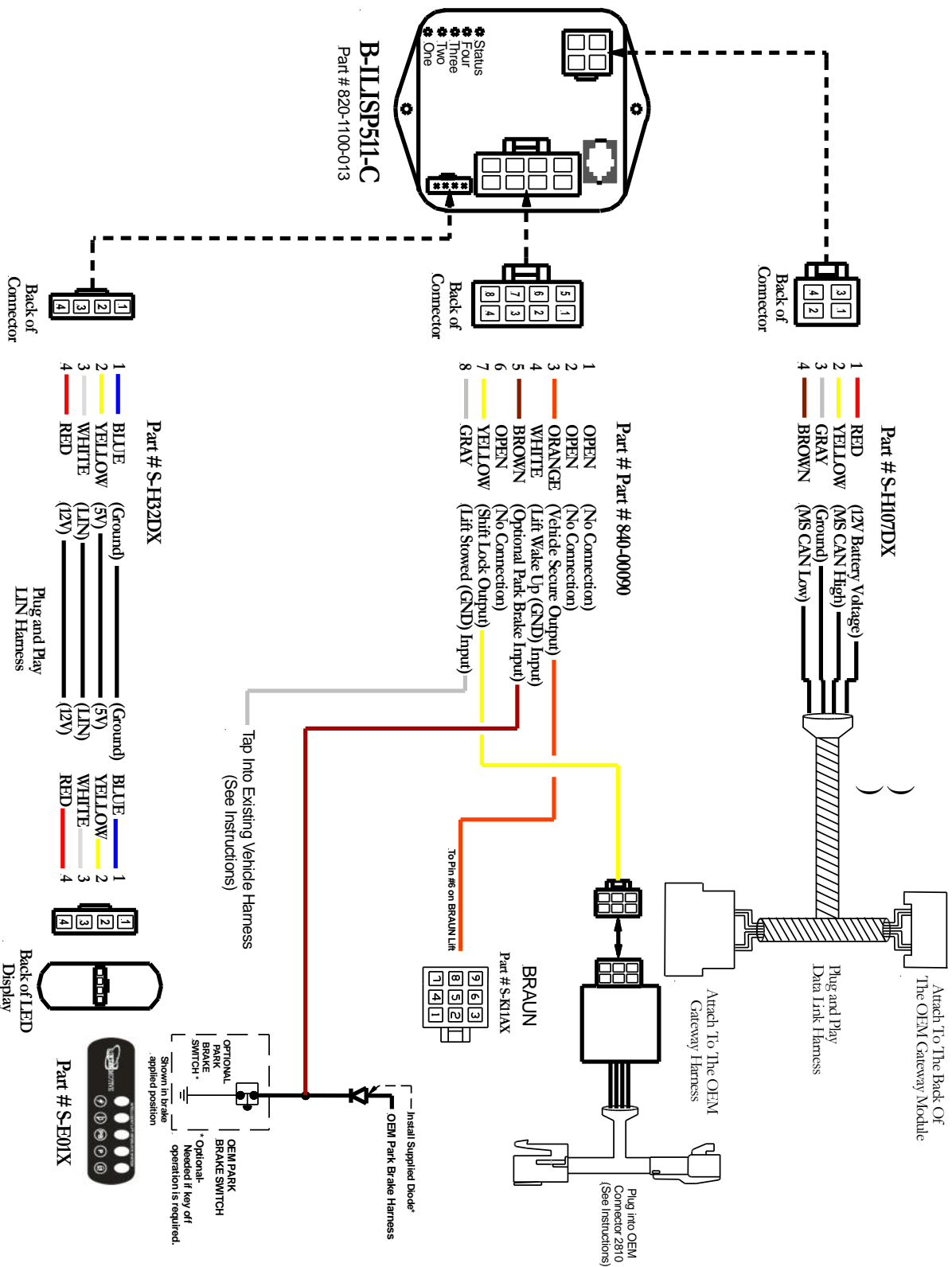

Submit product registration at www.intermotive.net

If the B-ILISP511-C fails any step in the Post Installation Check List, review the installation instructions and check all connections. If necessary, call InterMotive Technical Support at (530) 823-1048.

B-ILISP511-CDP Plug and Play Harness

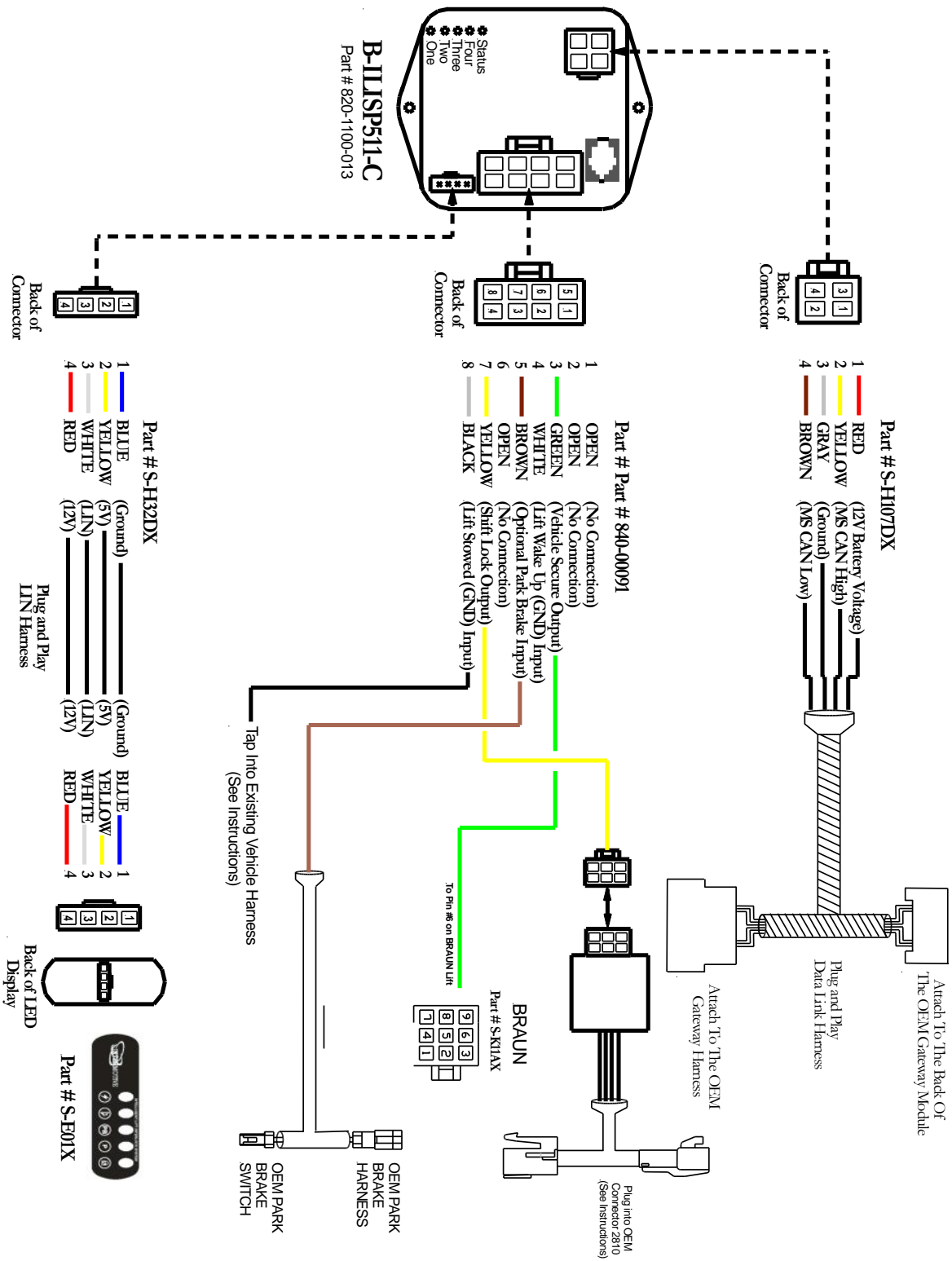

Submit product registration at www.intermotive.net

If the B-ILISP511-C fails any step in the Post Installation Check List, review the installation instructions and check all connections. If necessary, call Intermotive Technical Support at (530) 823-1048.