

B-BOM507-BC Black Out Module

2017 - 2022 Ford F250-F550

Contact InterMotive for additional applications



Introduction

The B-BOM507 module has the ability to eliminate all exterior lighting (except DRL's if activated) to aid in covert operations. When activated, with the headlights turned off, The B-BOM507 will eliminate the reverse lights and the Service Brake lights.

Installation Instructions

Disconnect vehicle battery before proceeding with installation.



WARNING
Disconnect the battery to
prevent setting a check engine
light.

IMPORTANT - READ BEFORE INSTALLATION

It is the installer's responsibility to route and secure all wiring harnesses where they cannot be damaged by sharp objects, mechanical moving parts and high heat sources. Failure to do so could result in damage to the system or vehicle and create possible safety concerns for the operator and passengers.

It is important to avoid placing the module where it could encounter strong magnetic fields from high current cabling connected to motors, solenoids, etc. Also avoid radio frequency energy from antenna's or inverters next to the module. Finally, avoid high voltage spikes in vehicle wiring by always using diode clamped relays when installing upfitter circuits.

B-BOM507-BC Module

Remove the lower dash panel below the steering column area and find a suitable location to mount the B-BOM507-BC module. Locate the module in an area away from any external heat sources (engine heat, heater ducts, etc.). Do not actually mount the module until all wire harnesses are routed and secure. The last step will be to mount the module.

B-BOM507-BC Module Mounting

Ensure all harnesses are properly connected and routed, and are not hanging below the dash area. Mount the B-BOM507-BC module using screws or double sided tape. Reinstall the lower dash panel.

Gateway Plug and Play Harness (6-pin connector)

1. Locate the vehicles Gateway Module (C2431). It will be mounted below the lower left dash panel.
2. Remove the harness behind the Gateway module by pressing the locking tab and pulling outward.
3. Plug the Female side of the InterMotive Gateway Harness into the back of the Gateway module. Ensure the connection is fully seated and secured by the locking tab.
4. Plug the Male side of the InterMotive Data Link Harness into Gateway harness.
5. Secure the BOM Gateway harness so that it does not hang below the lower dash panel.

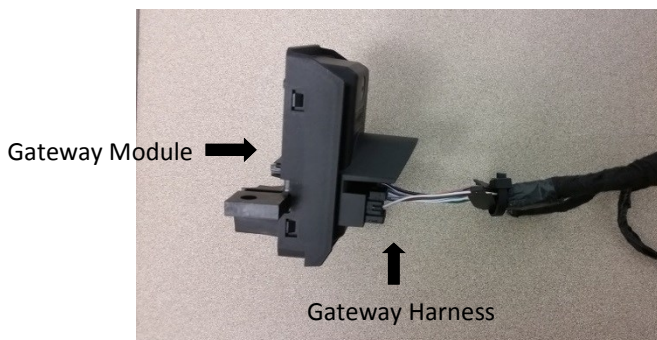

InterMotive Plug and Play Gateway Harness

4-Pin BOM LCO Connector Pin-Out Definition

Connector J5 contains the B-BOM507-BC (LCO) pins. Each output is rated at 1A.

The 4 LCO pins on connector J5 are defined as follows (supplied cable harness S-H111BX):

- Pin #1 - LCO 1, Purple Wire, Cargo Lamp Circuit (page 6).
- Pin #2 - LCO 2, Pink Wire, Cluster Dimmer Down (page 10)
- Pin #3 - LCO 3, Yellow Wire, Chime Mute Output (page 11)
- Pin #4 - LCO 4, Tan Wire, Cluster Dimmer Up (page 10)

Connect the outputs to the vehicle equipment as indicated.



4 Pin Output

4-Pin BOM Relay Connector Pin-Out Definition

Connector J8 contains the 4 BOM fused relay output pins. These 4 fused output pins are connected to 4 relay outputs. Each relay output is capable of 10A maximum.

The 4 fused relay output pins on connector J8 are defined as follows (supplied cable harness S-H117HX):

- Pin #1 - Dark Brown, connect to BCM side of Center High Mounted Brake Lamp Circuit (page 6).
- Pin #2 - Green/Brown, connect to BCM side of Reverse Lamp Circuit (page 5).
- Pin #3 - Green/Orange, connect to BCM side of Right Brake Lamp Circuit (page 7).
- Pin #4 - Grey/Orange, connect to BCM side of Left Brake Lamp Circuit (page 7).

Pin # 1 2 3 4

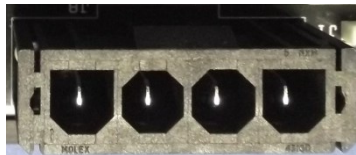

4 Pin Output

16-Pin BOM Relay Connector

The 16 Pin Molex connector will be used to connect the harness side of the rear light circuits.

Pin #3 - Black, connect female bullet to male bullet from the included momentary switch (photo below).

Pin #9 - Orange, connect to harness side of Center High Mounted Brake Lamp Circuit (page 6).

Pin #11 - Green, connect to harness side of Reverse Lamp Circuit (page 5).

Pin #13 - Blue, connect to harness side of Right Brake Lamp Circuit (page 7).

Pin #15 - Gray, connect to harness side of Left Lamp Circuit (page 7).

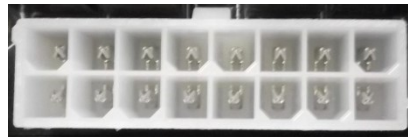

16 Pin Molex

4-Pin BOM Input Connector Definition

Connector J4 contains the BOM's 4 discrete wire inputs. Two of these are active low (1 and 2), The active low inputs have their own internal pull up resistors so they can be left floating when not used or not active.

The 4 input pins on connector J4 are defined as follows:

- Pin #1 - Blackout Input, Active low, Green/White Wire, Momentary low to activate Blackout Mode, connect the female bullet to the male bullet from the included momentary switch (photo below).
- Pin #2 - Armed Input Active low, Violet Wire, Momentary low to activate DarkCar. Connect this wire to a momentary switch that will ground the input. (Optional)
- Pin #3 - Blackout Input, Active High, Red/White Wire, Momentary +12V to activate Blackout Mode.

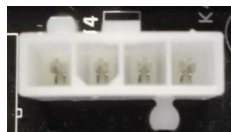

4 Pin Input

Momentary Switch

Drill a 16mm (0.630") hole in the desired mounting location. Route the momentary switch harness through the hole and mount the switch in the hole. Connect the bullets to the mating bullets from the B-BOM507-BC module.



BCM Connections

Locate the BCM near the passenger compartment. Locate the connector **C2280C** plugged into the BCM and disconnect it. Refer to page 9 for connector location. The supplied white 4-pin pigtailed will be tapping into several of these wires.

Note: Performing one step at a time, these connections must be made using solder and the supplied heat shrink tubing. Cut the tubing to 1" lengths for this purpose.

Cargo Lamps Circuit

1. Locate Pin #26 White wire of connector C2280C.
2. Verify with DVM there is 12 volts when cargo lamps are on and 0V when cargo lamps are off.
3. Cut the White wire about 3 inches from the connector
4. Attach the BCM side of the White wire to pin 30 of the relay. (Violet/White wire)
5. Attach the connector side of the White wire to pin 87A of the relay. (Violet/Black wire)
6. Locate the Purple wire, pin 1 (4 pin connector) on the BOM module and attach to pin 86 of the relay.
7. Attach a ground to pin 85 of the relay.
8. Securely mount relay.

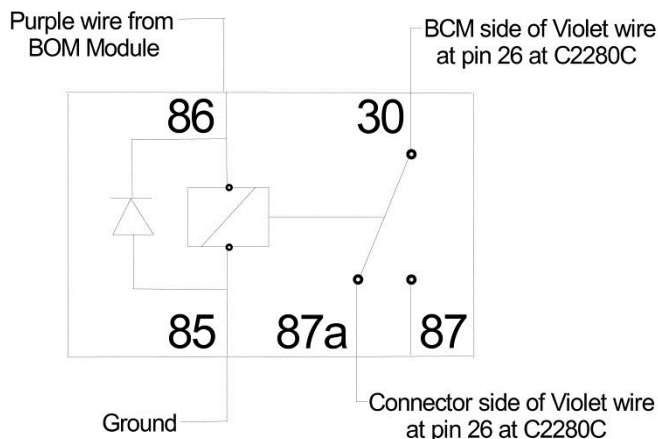

Reverse Lamp Circuit

The supplied **male** pigtail has Green/Brown wire and the **female** pigtail has the Green wire.

1. Locate Pin #11 Green/Brown wires of Connector C2280C.
2. Verify with a DVM that there is 12V on the Green/Brown wires when the vehicle is in Reverse and 0V when the vehicle is in any gear other than Reverse.
3. Cut the Green/Brown wire, pin #11 about 3 inches from the connector.
4. Attach the BCM side of the Green/Brown wire, pin 11 to the Green/Brown wire in the **male** pigtail.
5. Attach the harness side of the Green/Brown wire, pin 13 to the Green wire in the **female** pigtail.
6. Plug connector back into the BCM.

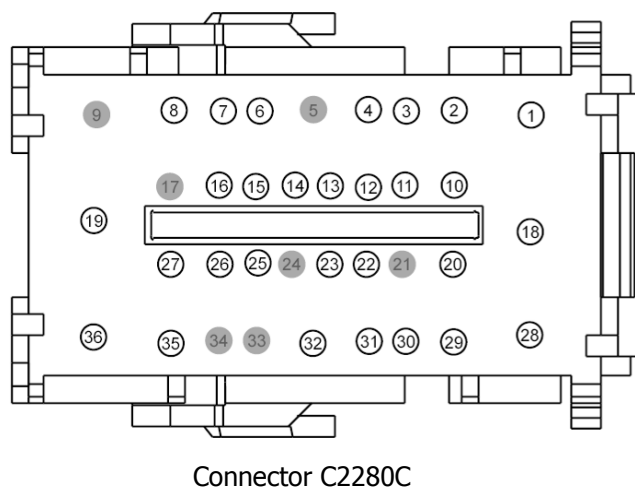

Continue to next page.

BCM Connections (cont.)

Locate the **blue** connector **C2280E** plugged into the BCM and disconnect it. Note the pin numbers on the connector. Refer to page 9 for connector location. The supplied white 4-pin pigtails will be tapping into several of these wires.

Note: Performing one step at a time, these connections must be made using solder and the supplied heat shrink tubing. Cut the tubing to 1" lengths for this purpose.

Center High Mounted Brake Lamp Circuit

The supplied **male** pigtail has Brown wire and the **female** pigtail has the Orange wire.

1. Locate Pin #13 Brown wires of Connector C2280E. It will be a 22 gauge wire.
2. Verify with a DVM that there is 12V on the Brown wire when the Service Brake is pressed and 0V when the Service Brake is *not* pressed.
3. Cut the Brown wire, pin #13 about 3 inches from the connector.
4. Attach the BCM side of the Brown wire, pin 13 to the Brown wire in the **male** pigtail.
5. Attach the harness side of the Brown wire, pin 13 to the Orange wire in the **female** pigtail.

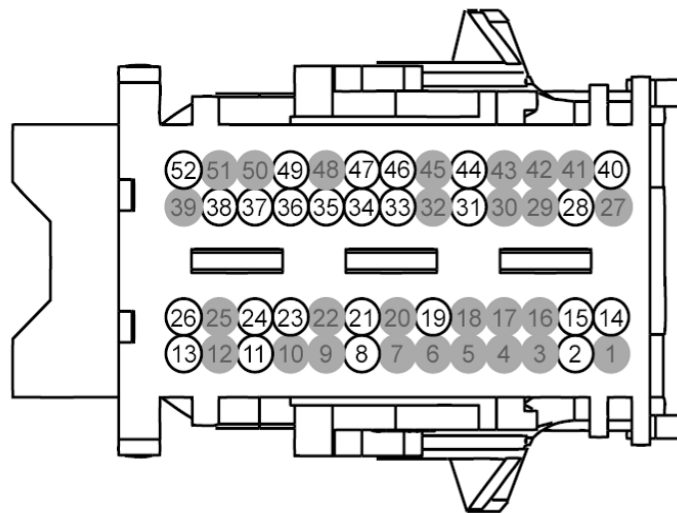

Connector C2280E

BCM Connections (cont.)

1. Locate the **blue** connector **C2280E** plugged into the BCM and disconnect it. Note the Pin Numbers on the connector. The supplied white 4-pin pigtails will be tapping into several of these wires.

The supplied **male** pigtail has Green/Orange and Gray/Orange wires and the **female** pigtail has the Blue and Gray wires.

Right Brake Lamp Circuit

1. Locate Pin #52 Green/Orange wire on connector C2280E.
2. Verify with a DVM that there is 12V on the Green/ Orange wire when the Service Brake is depressed and 0V when the Service Brake is *not* depressed.
3. Cut the Green/Orange wire, pin #52 about 3 inches from the connector.
4. Attach the BCM side of the Green/Orange wire, pin #52 to the Green/Orange wire in the **male** pigtail.
5. Attach the harness side of the Green/Orange wire, pin #52 to the Blue wire in the **female** pigtail.

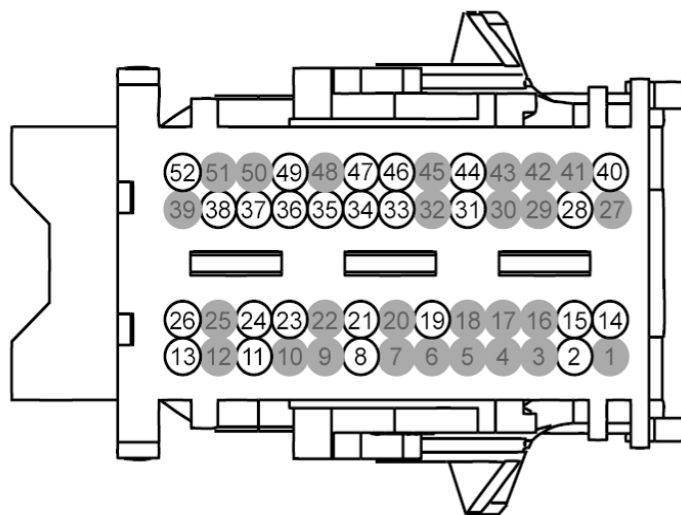

Connector C2280E

Left Brake Lamp Circuit

1. Locate Pin #26 Gray/Orange wire on connector C2280E.
2. Verify with a DVM that there is 12V on the Grey/Orange wire when the Service Brake is depressed and 0V when the Service Brake is *not* depressed.
3. Cut the Grey/Orange wire, pin #26 about 3 inches from the connector.
4. Attach the BCM side of the Gray/Orange wire, pin 26 to the Gray/Orange wire in the **male** pigtail.
5. Attach the harness side of the Gray/Orange wire, pin 26 to the Gray wire in the **female** pigtail.

Auxiliary Lamp Module 2017-2019 (if equipped)

The vehicle will have an Auxiliary Lamp module if there are TWO brake lamps on the left and right side. Skip this step if not equipped.

The Auxiliary Lamp Module controls the secondary brake lights and is located on the driver side compartment. Locate connector **C263C** under the right hand side on the instrument cluster.

This part of the installation will require 2 additional relays.

Left Brake Circuit

1. Locate Pin #1 Gray/Orange wire of connector C263C.
2. Verify with DVM there is 12 volts when brake lamps are on and 0V when brake lamps are off.
3. Cut the Gray/Orange wire about 3 inches from the connector
4. Attach the Connector side of the Gray/Orange wire to pin 30 of relay 1.
5. Attach the harness side of the Gray/Orange wire to pin 87A of relay 1.
6. Locate the Purple wire, pin 1 (4 pin connector) on the BOM module and attach to pin 86 of relay 1
7. Attach a ground to pin 85 of relay 1.
8. Securely mount relay 1.

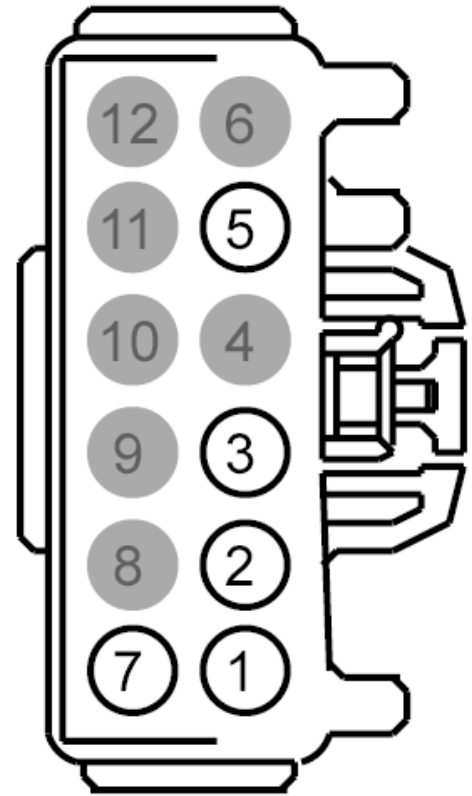

Connector C263C

Right Brake Circuit

1. Locate Pin #2 Green/Orange wire of connector C263C.
2. Verify with DVM there is 12 volts when brake lamps are on and 0V when brake lamps are off.
3. Cut the Green/Orange wire about 3 inches from the connector
4. Attach the Connector side of the Green/Orange wire to pin 30 of relay 2.
5. Attach the harness side of the Green/Orange wire to pin 87A of relay 2.
6. Locate the Purple wire, pin 1 (4 pin connector) on the BOM module and attach to pin 86 of relay 2.
7. Attach a ground to pin 85 of relay 2.
8. Securely mount relay.

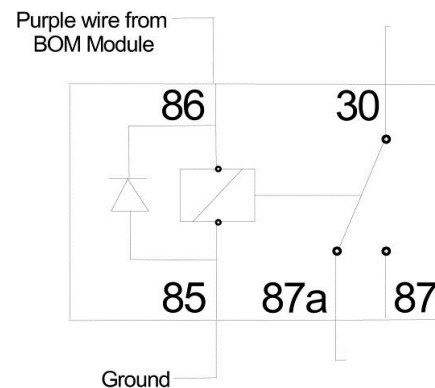

Dual Brake Lamps 2020 - 2022 (If Equipped)

Locate the **blue** connector **C2280D** (See page 11 for location) plugged into the BCM and disconnect it. Note the Pin Numbers on the connector. The supplied white 4-pin pigtails will be tapping into several of these wires.

The supplied **male** pigtail has Green/Orange and Gray/Orange wires and the **female** pigtail has the Blue and Gray wires.

Right Brake Lamp Circuit 2

1. Locate Pin #2 Yellow/Gray wire on connector C2280D.
2. Verify with a DVM that there is 12V on the Yellow/Gray wire when the Service Brake is depressed and 0V when the Service Brake is *not* depressed.
3. Cut the Yellow/Gray wire, pin #2 about 3 inches from the connector.
4. Attach the BCM side of the Yellow/Gray wire, pin #2 to the Green/Orange wire in the **male** pigtail.
5. Attach the harness side of the Yellow/Gray wire, pin #2 to the Blue wire in the **female** pigtail.

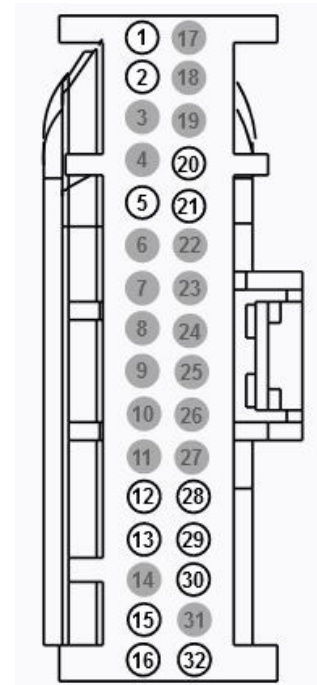

Connector C2280D

Left Brake Lamp Circuit 1

1. Locate Pin #1 Green wire on connector C2280D.
2. Verify with a DVM that there is 12V on the Green wire when the Service Brake is depressed and 0V when the Service Brake is *not* depressed.
3. Cut the Green wire, pin #1 about 3 inches from the connector.
4. Attach the BCM side of the Green wire, pin 1 to the Gray/Orange wire in the **male** pigtail.
5. Attach the harness side of the Green wire, pin 1 to the Gray wire in the **female** pigtail.

Dual Brake Lamps 2020 - 2022 (If Equipped)

Skip this step if not equipped.

Locate **C2280E** (See page 11 for location). This part of the installation will require 2 additional relays.

Left Brake Circuit 2

1. Locate Pin #24 White/Green wire of connector C2280E.
2. Verify with DVM there is 12 volts when brake lamps are on and 0V when brake lamps are off.
3. Cut the White/Green wire about 3 inches from the connector
4. Attach the Connector side of the White/Green wire to pin 30 of relay 1.
5. Attach the harness side of the White/Green wire to pin 87A of relay 1.
6. Locate the Purple wire, pin 1 (4 pin connector) on the BOM module and attach to pin 86 of relay 1
7. Attach a ground to pin 85 of relay 1.
8. Securely mount relay 1.

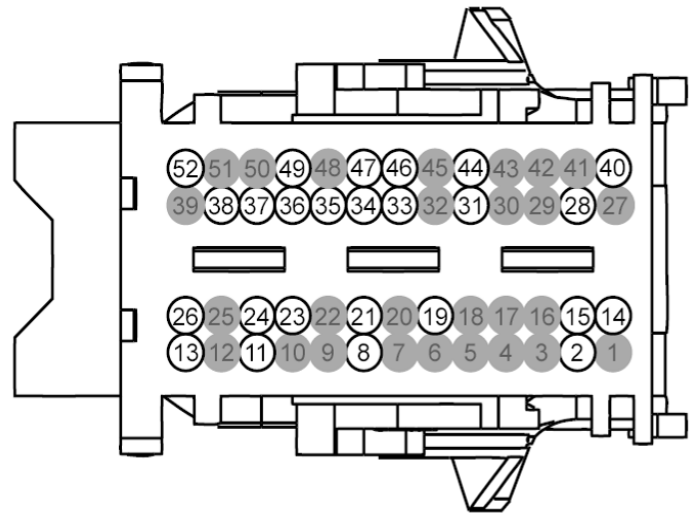

Connector C2280E

Right Brake Circuit 1

1. Locate Pin #23 Gray/Violet wire of connector C2280E.
2. Verify with DVM there is 12 volts when brake lamps are on and 0V when brake lamps are off.
3. Cut the Gray/Violet wire about 3 inches from the connector
4. Attach the Connector side of the Gray/Violet wire to pin 30 of relay 2.
5. Attach the harness side of the Gray/Violet wire to pin 87A of relay 2.
6. Locate the Purple wire, pin 1 (4 pin connector) on the BOM module and attach to pin 86 of relay 2.
7. Attach a ground to pin 85 of relay 2.
8. Securely mount relay.

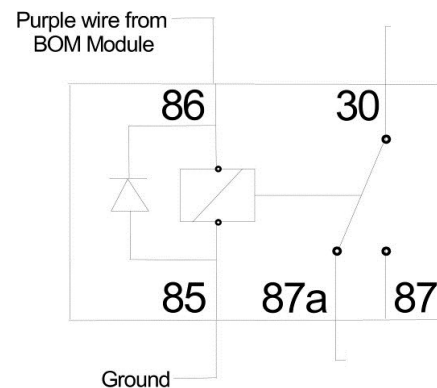

BODY CONTROL MODULE (BCM)

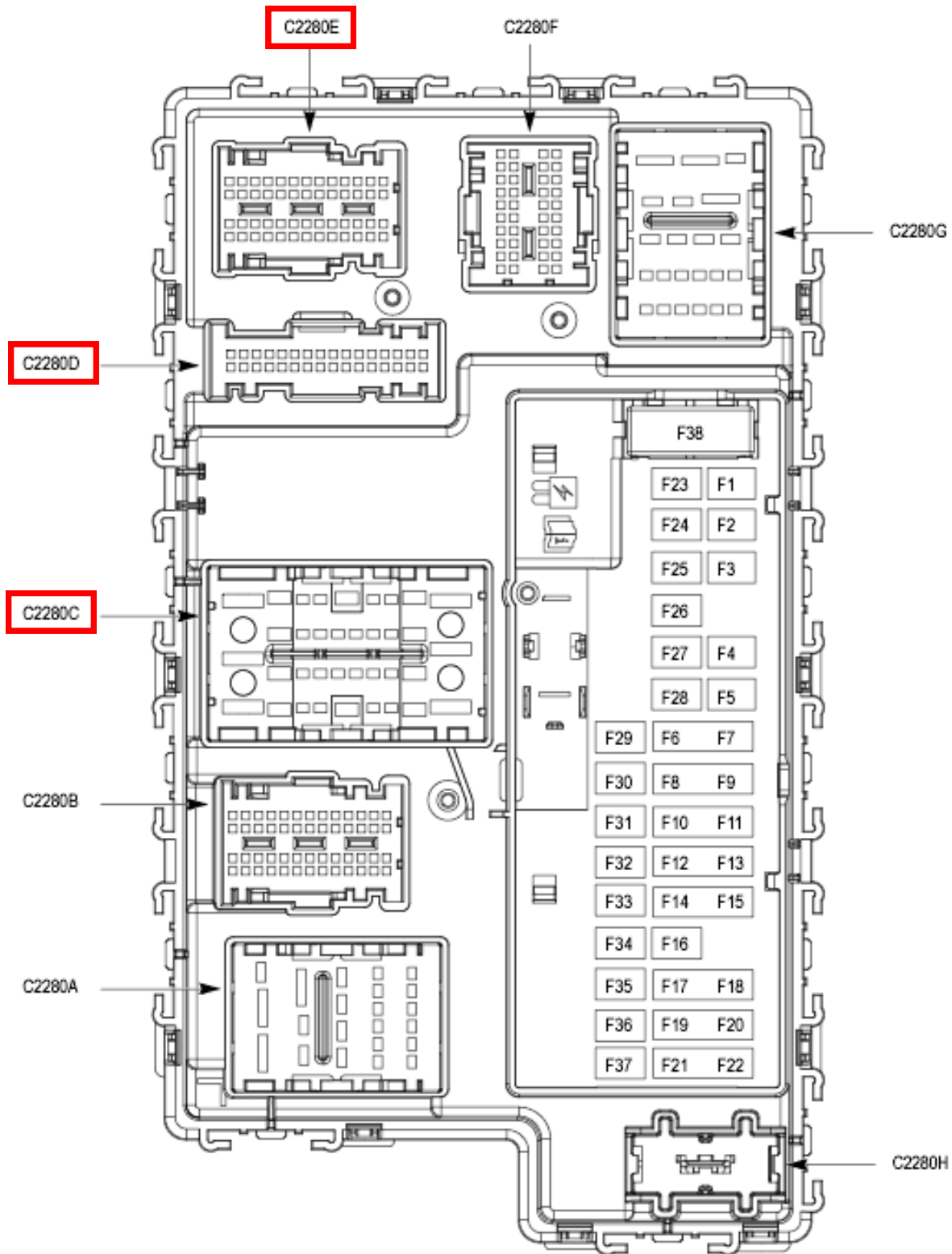

Cluster Control Installation Instructions

When in Blackout mode the module will turn the cluster backlighting off. The following two connections must be made for this feature to function correctly.

Remove Headlamp switch from panel to get to connector C205.



Head Lamp Switch

Connector:	Description	Color	Name
C205	HEADLAMP SWITCH		1440

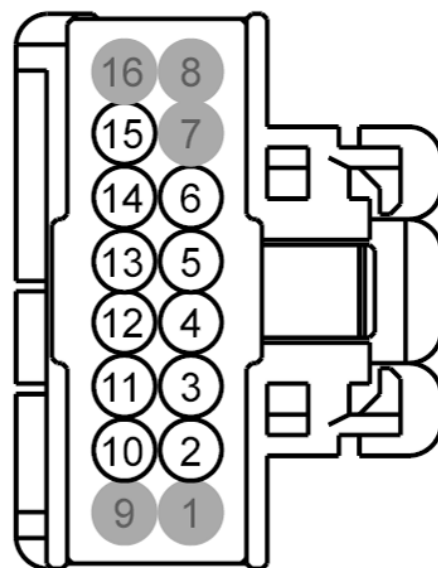

Head Lamp Switch Connector

Dim Down Circuit

1. Locate Pin #3 (Brown wire) on C205.
2. Strip some of the insulator and momentarily ground the wire to verify the cluster brightness goes down.
3. Connect the circuit to the Pink Wire pin 2 of the 4 pin Molex connector.

Dim Up Circuit

1. Locate Pin #6 (Yellow wire) on C205.
2. Strip some of the insulator and momentarily ground the wire to verify the cluster brightness goes up.
3. Connect the circuit to the Tan Wire pin 4 of the 4 pin Molex connector.



4 Pin Output

Chime Mute Installation Instructions

Yellow Wire Connection

The B-BOM507-BC kit provides a harness which consists of a white 4 pin connector with a Yellow wire.

Connect the yellow wire to the vehicle as follows:

Locate the BCM near the passenger compartment (See page 11 for location). Locate the **blue** connector **C2280E** plugged into the BCM and disconnect it. Note the Pin Numbers on the connector.

1. Locate Pin #33 Green Wire. It will be a 26 gauge wire.
2. Verify with a DVM that there is Ground signal on the Brown wire when the Driver Door is closed.
3. Verify Ground signal goes away when Driver Door is open.
4. Strip a small amount of wire insulation from the Brown wire (do not cut wire) and attach the Yellow wire using solder and tape.

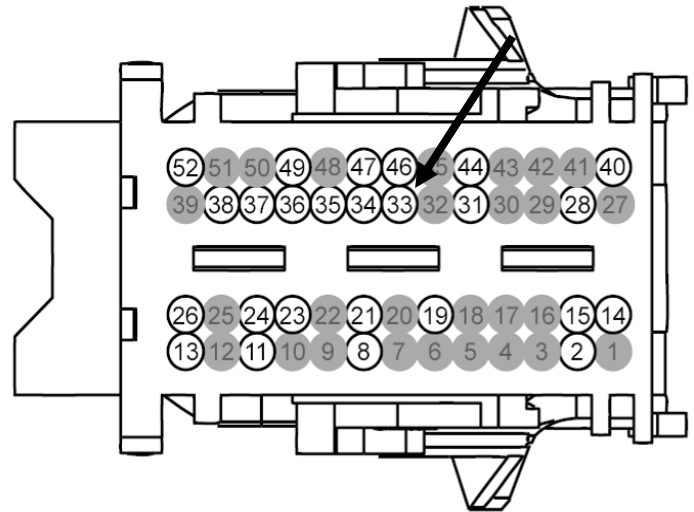

Connector C2280E

Chimes Mute Post Installation Test

With vehicle in Park and the Park Brake applied:

1. Turn Key to Run (do not start engine) and plug the 6 pin Data Link connector into the B-BOM507-BC module. This allows the B-BOM507-BC to read the vehicles VIN to verify which vehicle it is plugged into.
2. Verify that the LED's on the module are not scrolling (meaning it has successfully acquired and recognizes the VIN).
3. Verify the following chimes no longer sound:
 - **Door Ajar Warning Chime** - Key in Run (engine on or off), Trans in Park, Door ajar
 - **Key-in-Ignition Warning Chime** - Key in ignition (Off or ACC), door ajar
 - **Headlamps On Warning Chime** - Key removed, Headlights on, door ajar
 - **Safety Belt Warning Chime** - Key switched to Run, driver seatbelt unbuckled. Note: this last chime may sound occasionally due to the electrical architecture of the vehicle. This is normal behavior and cannot be avoided.

Post Installation / Check List

The following checks must be made after installation of the system, to ensure correct and safe operation. If any of the checks do not pass, do not deliver the vehicle. Recheck all connections per the installation instructions.

1. Turn ignition key on (to "Run").
2. Apply the Parking Brake and Turn Off all lights (High Beams, Low Beams, and Parking Lights).
3. Arm vehicle (if necessary).
4. Press the momentary switch.
5. Verify Instrument Cluster turns OFF.
6. Hold Service Brake and verify the Brake lights are disabled.
7. Turn on Low Beams, this will disable Blackout.
8. Hold Service Brake and verify the Brake Lights are lit.
9. Verify Instrument Cluster backlighting comes on.
10. Turn Off all lights (High Beams, Low Beams, and Parking Lights).
11. Press the momentary switch.
12. Place transmission in Reverse and verify the reverse lights are not lit.
13. Turn on Low Beams.
14. Verify that the Reverse Lights are On.

DO NOT PUT VEHICLE IN SERVICE IF IT DOES NOT PASS ALL OF THE ABOVE TESTS

Contact InterMotive at 530-823-1048 for technical assistance

Diagnostics

Diagnostic mode is entered by pressing the test button on the module. The module provides diagnostic LEDs which illuminate according to the following table. There are multiple pages of diagnostics and the page can be determined by the Status LED. Pressing the test button will cycle through the different pages.

STATUS LED	1-1	2-2	3-3
LED 1	Chimes Enabled	Black Out Active	High Beams
LED 2	Dark Car Control	Armed Enabled	Speed override
LED 3	Not Used	VSS < Max speed	Internal Use
LED 4	Not Used	Headlamp Switch OFF	Internal Use

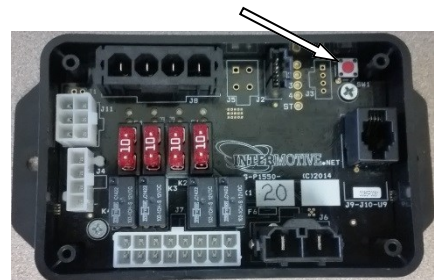

Blackout Operating Instructions

System Operation

The B-BOM507-BC module has the ability to eliminate all exterior lighting (except DRL's if activated) to aid in covert operations. When activated, it will eliminate the parking lamps, reverse lights, and the Service Brake lights.

ARMED Input

The ARMED Input is used only if the vehicle has Dark Car disabled. These are not ideal conditions for the vehicle to be "Blacked Out" so the ARMED Input will enable Dark Car. If the Input is not "Armed", the module will not enter Black-Out Mode.

Note: The input is not used if vehicle has Dark Car enabled.

Black Out Preconditions:

- Parking lights must be OFF.
- Headlights must be OFF.
- Vehicle speed must be less than exit speed. (configurable)
- Vehicle Armed input enabled (if used).
- Press the momentary switch.

Once in Black Out mode, the stop lamps and reverse lamps are inactive. The module will also dim the instrument panel cluster to its lowest level.

To disable Black Out, apply one of the following:

- Press the momentary switch.
- Turn ON parking lights.
- Turn ON Headlights.
- Vehicle speed goes over exit speed.

To bypass the "exit speed", hold the Black Out input while driving and the module will keep the tail lights inactive.

Speed Override

The configurable Exit Speed is used for safety purposes and the speed can be set between 5-20 MPH. To bypass the Exit Speed, enter Black Out Mode by momentarily applying the Black Out Input. Once entered, hold the momentary switch and the module will keep the lights disabled at any speed as long as the input is continuously pressed.

U.S. Patent #9,469,261

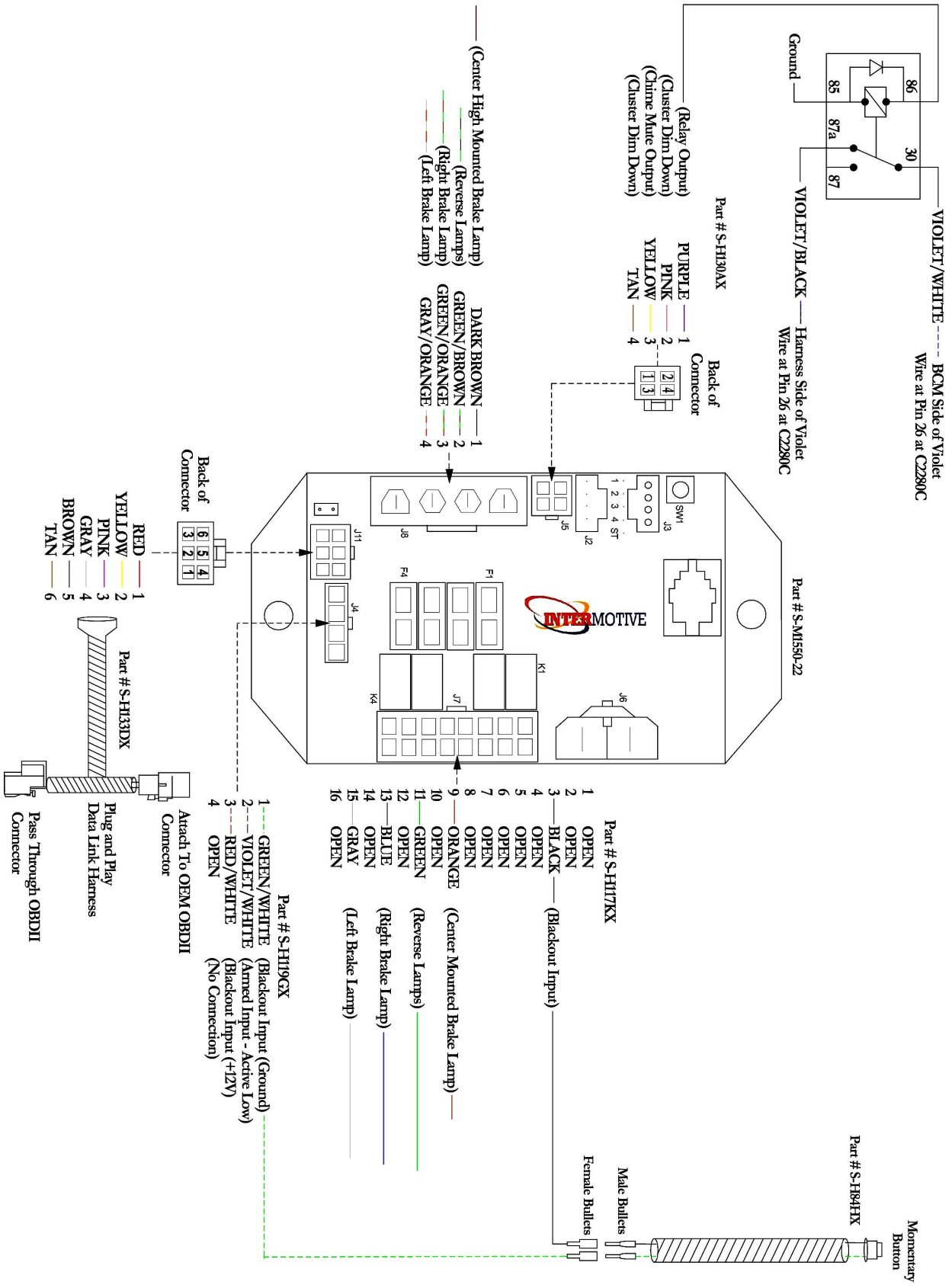

Submit product registration at www.intermotive.net

If the B-BOM507-BC fails any step in the Post Installation Test, review the installation instructions and check all connections. If necessary, call Intermotive Technical Support at (530) 823-1048.