

Idle Timer Controller - A-ITC620-A-P8/P10
P8 — 2009-2018* Chevrolet Express/GMC Savana
P10 — 2017*-2025 Chevrolet Express/GMC Savana
Contact InterMotive for additional vehicle applications
*** See Page 3 for specific details on 2017-2018 vehicles**



Introduction

The A-ITC620-A is an anti-idle system which will shut off gas or diesel engines that are left idling for an extended period of time in Park or neutral. The default timer will shut off the engine after 5 minutes of idling if the Park Brake is applied, and 15 minutes if the Park Brake is not applied. This is similar to CARB diesel anti-idling requirements.

Installation Instructions

**Disconnect vehicle batteries before proceeding with installation
(vehicle may have more than one battery)**



IMPORTANT—READ BEFORE INSTALLATION

It is the installer's responsibility to route and secure all wiring harnesses where they cannot be damaged by sharp objects, mechanical moving parts and high heat sources. Failure to do so could result in damage to the system or vehicle and create possible safety concerns for the operator and passengers.

Avoid placing the module where it could encounter strong magnetic fields from high current cabling connected to motors, solenoids, etc. Avoid radio frequency energy from antennas or inverters next to the module. Avoid high voltage spikes in vehicle wiring by always using diode clamped relays when installing upfitter circuits.

A-ITC620 Module

Remove the lower dash panel below the steering column and find a suitable location to mount the module. Mount the module in an area away from any external heat sources (engine heat, heater ducts, etc.). Do not mount the module until all wire harnesses are routed and secure. The last step of the installation is to mount the module. When installing the harnesses, leave several inches of take-out such that the module can be removed if necessary.

Data Link Harness (6-Pin Connector)

1. Locate the vehicle OBDII Data Link Connector located below the lower left dash panel.
2. Remove the mounting screws for the OBDII connector. Plug the red connector from the A-ITC620-A Data Link T- Harness into the vehicle OBDII connector. Ensure the connection is fully seated and secure with the supplied wire tie.
3. Mount the Black connector from the A-ITC620-A Data Link Harness in the former location of the vehicle OBD II connector.
4. Secure the harness so that it does not hang below the lower dash panel.
5. Plug the 6-pin connector from the Data Link Harness into the 6-Pin connector on the A-ITC620-A module.



A-ITC620-A Harness (12-Pin Connector and 4-Pin Connector)

Most OEM Ignition Switch wires are no longer capable of supplying power to aftermarket systems. Some vehicles now provide Ignition Power outputs that are isolated from the actual Ignition switch signals. If the desired isolated Ignition Output is not available, a relay must be installed to minimize current draw on the Ignition switch wires. The relay must include a kick-back diode to prevent damaging sensitive electronics.

Ignition Switch Connectors

Blunt Cut Connection

1. Remove the lower steering column trim cover. Locate the ignition switch connector and disconnect it from the switch.
2. Locate Pin #4 Red/White wire and Pin #5 Pink wire on the connector.

Confirm that the Pink wire is located between the Red/White wire and the White wire on the connector. There is a second pink wire at Pin #2, do NOT use this wire.

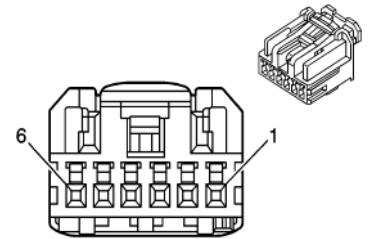

Front View of Connector

Performing one step at a time, attach the correct color wire to each white 2-pin connector wire end. These connections must be made by using solder and the supplied heat shrink tubing. Cut the tubing into 1" lengths for this purpose.

1. Find a place on the vehicle Ignition Harness with ample space to install the white 2-pin pigtail connectors. (Supplied with the A-ITC620-A.)
2. Cut the Ignition Switch Pin #4 Red/White wire and attach the ignition switch side to the female 2-pin connector Pin #1 Red wire.
3. Attach the Harness side of the Pin #4 Red/White wire to the male 2-pin connector Pin #1 Blue wire.
4. Cut the Ignition Switch Pin #5 Pink wire and attach the ignition side of the Pin #5 wire to the female 2-pin connector Pin #2 (Brown wire).
5. Attach the harness side of the Pin #5 Pink wire to the male 2-pin connector Pin #2 (Yellow wire).
6. Plug the two 2-pin Ignition connectors into the A-ITC620-A Harness.
7. Plug the 12 Pin connector of the A-ITC620-A Harness into the A-ITC620-A Module.
8. Plug the 4 Pin connector of the A-ITC620-A Harness into the A-ITC620-A Module.
9. Reattach the Ignition Switch Connector to the Ignition Switch.



Ignition Switch Connectors (Continued)

Plug and Play Connectors

Note: Before ordering a plug and play connector, it will be necessary to determine which ignition switch is installed on the vehicle. This can be determined by looking at the first 3 digits of the VIN. If the second VIN character is an "H" or the first three digits of the VIN are "7GZ", the vehicle is an incomplete vehicle manufactured by **Navistar (P10 version)**. All other combinations of the first three VIN characters will signify that the vehicle has been manufactured by **General Motors (P8 version)**. Manufacturing transitioned from General Motors to Navistar over the course of 2017-2018. If the vehicle is either 2017 or 2018 it is imperative to determine which connector is used on the vehicle.



**GM Ignition Switch Connector
2009-2018 — P8 version**



**Navistar Ignition Switch Connector
2017-2025 — P10 version**

The procedure for installing the plug and play connectors are the same for the Navistar and GM ignition switches.

1. Remove the lower steering column trim cover. Locate the Ignition Switch connector and disconnect it from the switch.



2. Remove the OEM 6 pin connector from the ignition switch and connect it to the female connector of the Idle-Lock harness. Connect the male Idle-Lock connector to the OEM ignition switch.



Optional Shutdown indicators and override inputs

There are 3 optional signals with "flying lead" wires provided for connecting to external equipment or devices as described below. These three signal are located on the A-ITC620-A modules 12 pin connector.

Warning beeper, lamp or LED output - Orange wire, Pin #2. This signal provides 12V when active. The maximum allowed draw on this circuit is 1/2 amp. If an LED is used, it must have either an integral resistor or one wired in series. (A typical value would be $13V/0.02A = 650$ ohms. 620 & 680 are standard values. Use 1/2Watt resistor). Attach this Orange wire to the positive input for the LED or beeper. Attach a ground wire to the negative side of the circuit. This output pulses repeatedly during the final 30 seconds of Shutdown.

Override High input - Green wire, pin #4. Applying 12V to this input will prevent engine shut down, and can be connected to equipment such as a PTO, pumps, compressors, etc.

Override Low input - Blue wire, pin #5. Applying ground to this input will prevent engine shut down, and can be connected to equipment such as a PTO, pumps, compressors, etc.

Ensure that unused flying leads will never make electrical contact with anything by taping, cutting, or extracting the wires (pin extraction requires Molex tool).

If the module's factory default settings will not be changed as described on the following page, proceed to the Post Installation Check List section.

Reconnect the vehicle batteries

Reconfiguration

A special Serial Communication Cable is available from Intermotive to use this method. You will be required to download and install the proper USB driver the first time you use this cable. All driver files are located online at: <http://www.intermotive.net>

- Find the correct drivers for your system and follow the steps to download the latest version (located under the "Driver Version" heading). If unsure about the installation process, contact InterMotive for assistance.
- Download and install the latest release of the Tera Term application from: <http://www.intermotive.net>
- Plug one end of the cable into your PC's USB port, and with the vehicle's key in the off position, plug the other end into the module's COM port.
- Open the Tera Term application. The Tera Term 'New Connection' window will open (see picture).

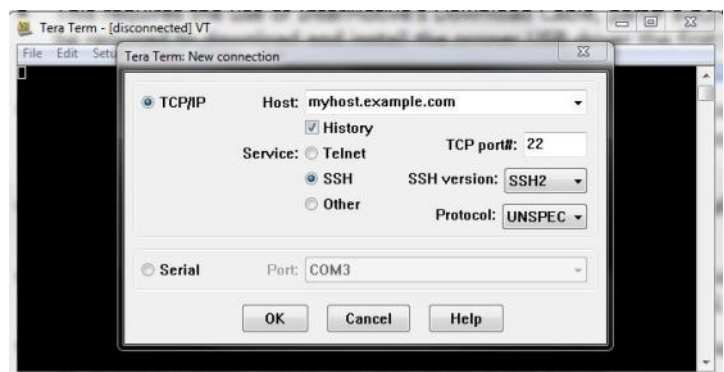

Reconfiguration (Continued)

- Click the 'Serial' button and choose the COM Port that the Intermotive Download Cable is connected to (typically the highest numbered COM Port). Click 'OK'.
- Under the 'Setup' tab, choose 'Serial Port'.
- In the next window, you will need to change several of the default parameters for the Port Settings as follows:
 - Baud rate: 57600
 - Data: 8 bits
 - Parity: None
 - Flow Control: None
 - Transmit delay: 0 msec/char, 0 msec/line
 - Click 'OK'.
- Tera Term setup is now complete.

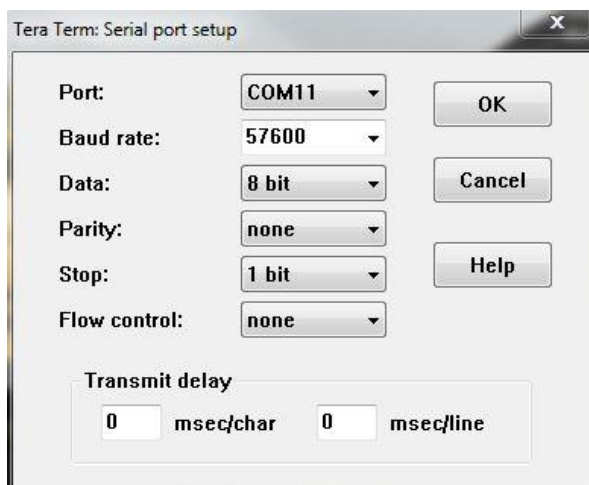

Reconfiguring the Idle Timer Controller (Optional)

1. Turn the vehicle key to the ON position. The ITC620-A module will wakeup and text will display on the open Tera Term window.

```
ITC Configuration Mode
You may modify ITC parameters by entering one of following numbers:
1 = Duration of the Idle Shutoff Timer
2 = The Minimum Engine Temperature for Idle Shutoff
3 = Driver Input ITC Override
Press Escape to Exit Configuration Mode

Change Parameter: 
```

Screenshot 1

2. If text does not appear, unplug the 6 pin connector from the ITC620-A module, wait several seconds and plug the connector back in.

3. If text still does not appear, go to Setup > Serial Port and try re-configuring Tera Term as described on the previous page. If unsuccessful, contact InterMotive for further assistance.

```
ITC Configuration Mode
You may modify ITC parameters by entering one of following numbers:
1 = Duration of the Idle Shutoff Timer
2 = The Minimum Engine Temperature for Idle Shutoff
3 = Driver Input ITC Override
Press Escape to Exit Configuration Mode

Change Parameter: 1
The Idle Shutoff Timer is currently set to: DEFAULT OPERATION
The maximum allowed timer length is 3000 seconds (50 minutes)
Enter new value in Seconds: 
```

Screenshot 2

4. With communication established, type in the word "config" (followed by the enter key) and the screen will look like Screenshot 1.

5. Enter the number (1, 2, or 3) of the parameter to be changed:

```
ITC Configuration Mode
You may modify ITC parameters by entering one of following numbers:
1 = Duration of the Idle Shutoff Timer
2 = The Minimum Engine Temperature for Idle Shutoff
3 = Driver Input ITC Override
Press Escape to Exit Configuration Mode

Change Parameter: 2
The Minimum Engine Temperature for Idle Shutoff is: 100 degrees F
Enter new value up to 200 degrees F: 
```

Screenshot 3

6. If 1 is selected, the screen will look like config Screenshot 2. Key in a new Idle Shutdown Time, in seconds, followed by the Enter key. Changing this value from the default setting will cause Park Brake to have no effect on the Idle Timer duration. To restore the default setting, enter the number 10,000 followed by the Enter key.

7. If 2 is selected, the screen will look like Screenshot 3. Key in a new minimum warm up temperature in degrees F, followed by the Enter key.

```
ITC Configuration Mode
You may modify ITC parameters by entering one of following numbers:
1 = Duration of the Idle Shutoff Timer
2 = The Minimum Engine Temperature for Idle Shutoff
3 = Driver Input ITC Override
Press Escape to Exit Configuration Mode

Change Parameter: 3
Driver Input ITC Override: Disabled
1 = Enable
2 = Disable
Change to Parameter: 
```

Screenshot 4

8. If 3 is selected, the screen will look like Screenshot 4. Changing this value will disable the idle timer reset based on the Service Brake, Parking Brake, and accelerator pedal.

9. Press ESC key when parameters are set correctly.

10. When finished, key off ignition and disconnect the Communication cable.

Post Installation Check List

Putting the module into Test Mode

It is recommended to mount the module after all post installation checks are complete.

1. Start the engine.
2. Enter Test Mode by pushing and holding the Service Brake while setting and releasing the Park Brake 4 times within 10 seconds. When successful, LED10 on the A-ITC620-A module will be lit.
3. Release the Service Brake. When this mode is active, the shut off timer is reduced to 15 seconds. LED 9 will come on for 1 second at the start of the shut off timer. A Park Brake, Service Brake, or Accelerator Pedal input will reset the timer. LED 9 will light to verify each input.
4. Also verify function of any lamp or buzzer connected to the optional indicator output. During the final 5 seconds the indicator will flash or sound multiple times until the engine is shut off.
5. Confirm LED10 goes off when engine is shut off.
6. Turn off the ignition. Status LED will light briefly.

A-ITC620 Module

Ensure all harnesses are properly connected and routed, and are not hanging below the dash area. Mount the module as described on page 1, and secure with screws or double sided tape. Reinstall the column trim cover and under dash panel.

If the A-ITC620-A fails any step in the Post Installation Check List, review the installation instructions and check all connections. If necessary, call InterMotive Technical Support at (530) 823-1048.

Leave in vehicle
Operating Instructions Idle Timer Controller - A-ITC620-A-P8/P10
P8 — 2009-2018* Chevrolet Express/GMC Savana
P10 — 2017*-2025 Chevrolet Express/GMC Savana
Contact InterMotive for additional vehicle applications
*** See Page 3 for specific details on 2017-2018 vehicles**



A-ITC620-A Overview

The A-ITC620-A is an anti-idle engine shut off system. It automatically shuts off the engine if the vehicle is left idling for an extended period of time in Park or Neutral, without operator input.

Default operation: with the Park Brake disengaged the engine will shut off after 15 minutes of idling. If the Park Brake is set, the idle time is 5 minutes before shut off.

Custom operation: A custom timer length may have been set by the final stage vehicle manufacturer. If this is the case, the engine will shut off after this time limit expires, regardless of the Park Brake being set, or not.

Ignition Power Restore and Restart

After an auto-shut off, the ignition key must be cycled off, then back on, before ignition power will be restored, and the vehicle can be restarted.

When A-ITC620-A has switched off Ignition power, there is still a small power draw from the batteries. This draw could potentially drain the batteries if the key is left ON and in the vehicle for several days. For this reason, as well as to prevent theft, the key should always be removed from the Ignition once the operator has finished with the vehicle.

Optional Shutdown Indicators

The vehicle's final stage manufacturer may have installed an optional indicator lamp or buzzer which A-ITC620-A will use to warn of impending engine shut down. If installed, it will flash or sound repeatedly during the final 30 seconds prior to Shut Off.

Applying Service Brake, Accelerator pedal or Park Brake will reset the shut down timer.

Timer Override Inputs

The A-ITC620-A provides Timer Override inputs which the vehicle manufacturer may have wired to other equipment (PTO, AC, etc...). This allows certain equipment on the vehicle to prevent engine shut down as necessary.

Once the optional equipment is switched off the A-ITC620-A will resume Idle Timer shut down operation.

ITC-620-A Plug-and-Play

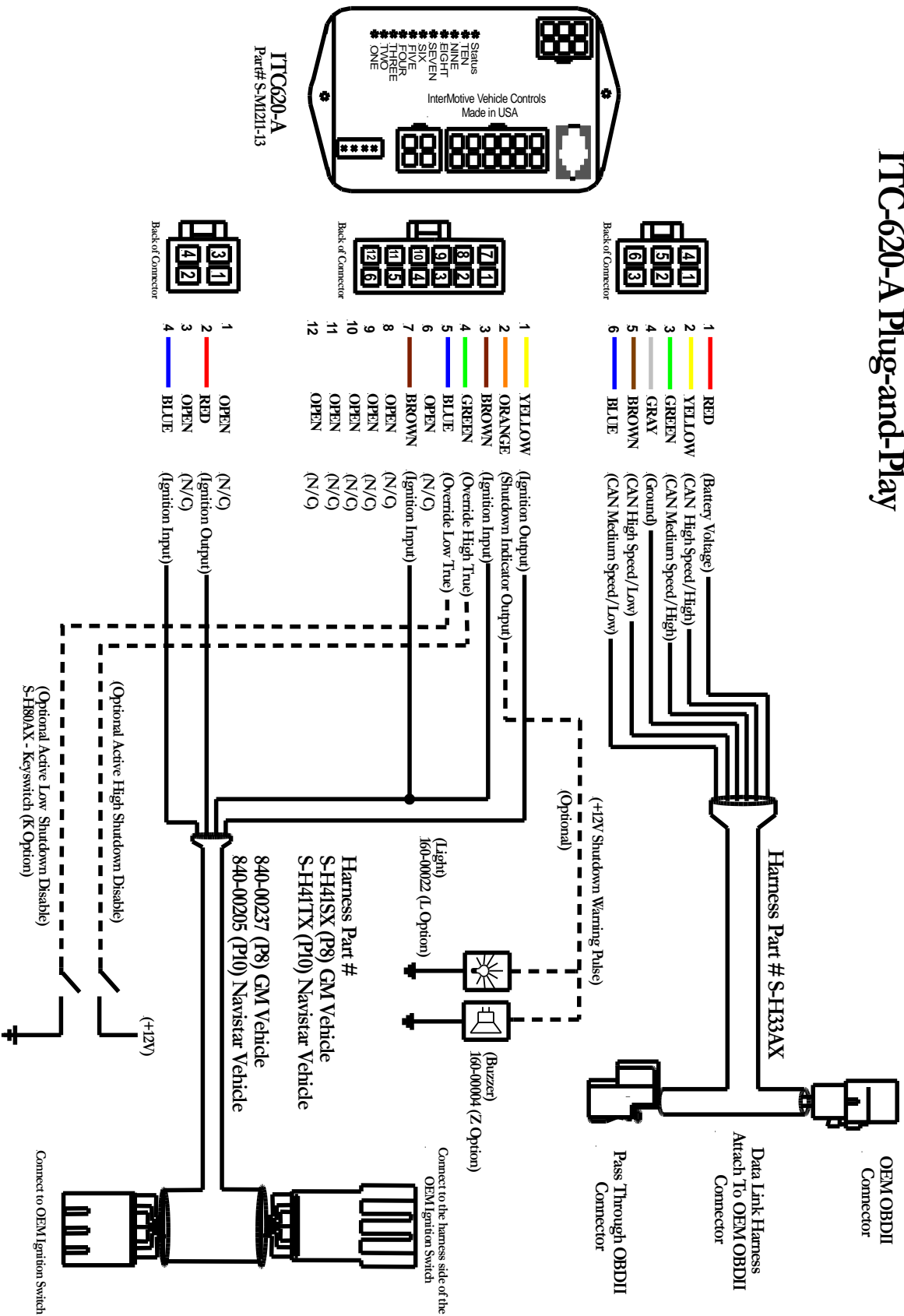

Submit product registration at www.intermotive.net

If the A-ITC620-A fails any step in the Post Installation Check List, review the installation instructions and check all connections. If necessary, call InterMotive Technical Support at (530) 823-1048.

This version A-ITC620-A blunt cut ignition is no longer offered. see PnP ignition solutions.

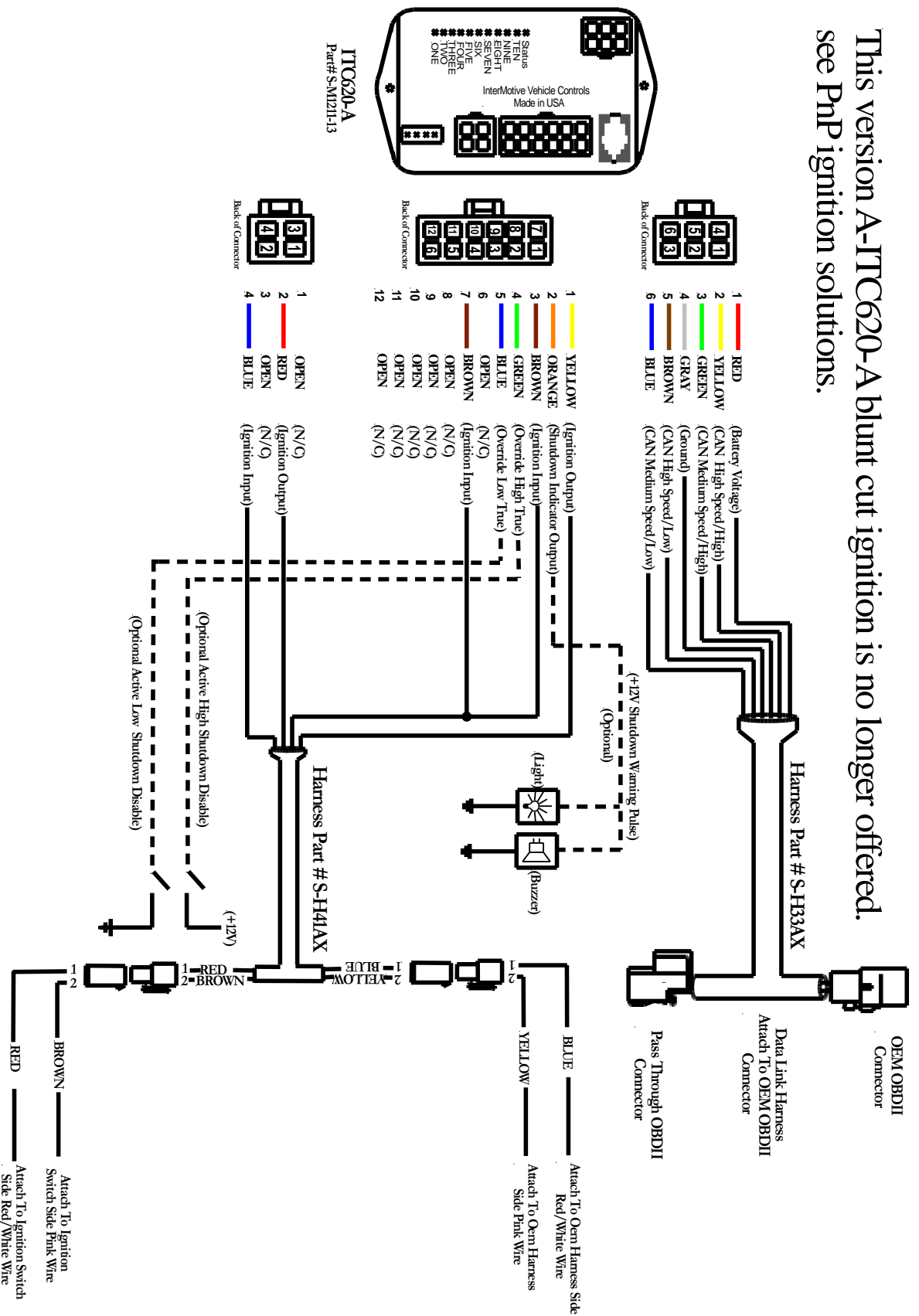

Submit product registration at www.intermotive.net

If the A-ITC620-A fails any step in the Post Installation Check List, review the installation instructions and check all connections. If necessary, call InterMotive Technical Support at (530) 823-1048.