



An ISO 9001:2000 Registered Company

# Intelligent Lift Interlock System (ILIS) Installation Instructions

## Part No: ILIS604-G 2005-2008 Chevrolet Uplander Mini-Van

To aid in installation, first gain access to the connection points. Remove the lower dash panel below the steering column. Also, gain access to the lift power switch and the lift door switch circuits. These are usually accessible in the front control panel. It is not necessary to cut any Chevrolet wires during the installation of the ILIS wire harness.

**LED DISPLAY PANEL (6-Pin Connector)** – Locate a suitable position on the dashboard, within view of the driver for the mounting of the ILIS LED Display Panel. The length of the display harness is 40". This is the maximum distance the display can be from the ILIS control module. Drill a 1" hole in the dashboard where you wish the center of the display to be. Attach the 6-pin end of the LED harness to the ILIS control module. Run the 10-pin end of the harness under the dash and out through the 1" hole. Attach the 10-pin end of the display harness to the ILIS LED Display Panel. Ensure panel is level, and secure using the supplied screws.

The two blunt cut wires (red and black) are for optional backlighting of the lower icons. There are three installation options:

1. Do not connect the wires. The display will function properly, but the lower icons will not be backlit.
2. Connect the black wire to ground and the red wire to a 12V ignition switched power source. This will allow the lower icons to be backlit with the ignition in the "on" position.
3. Connect the black wire to ground and the red wire to a 12V headlamp switched power source. This will allow the lower icons to be backlit only when the headlamps are on.

**MAIN HARNESS** - Position the main harness such that the 12-pin connector is in position to be installed into the control module. *The connector should not be installed into the module until the main harness is fully installed. All Connections must be made with ignition power OFF!* The connection points to be made for the installation of the main harness are listed below.

**Black 8-Pin Connector** – Locate the black, 8-pin Chevrolet connector located behind the lower dash panel above the data link connector (see diagram). Separate the Chevrolet connector and plug the ILIS 8-pin connector between the two ends of the Chevrolet connector. (See photo).

**Note:** If the vehicle is not equipped with cruise control, this connector will not exist in the vehicle. If this is the case, cut the 8 pin T adapter off on the InterMotive harness and discard. You will now have a red wire and a black wire. Attach the red wire to a fused ignition power circuit. This circuit must have voltage in both the run and crank key positions and only those positions. Run the black wire to a known good ground point.



**Black 2-Pin Connector** – Locate the black, 2-pin Chevrolet connector located on the shift lock solenoid (see photo). Separate the Chevrolet connector and plug the ILIS 2-pin connector between the two ends of the Chevrolet connector.



**Black 1-Pin Connector** – Disconnect the black, single-wire Chevrolet connector from the park brake switch (see photo). Plug the female side of the connector from the Brown wire on the ILIS main harness to the parking brake. Install the male side of the connector on the brown wire to the female connector in the Chevrolet harness.

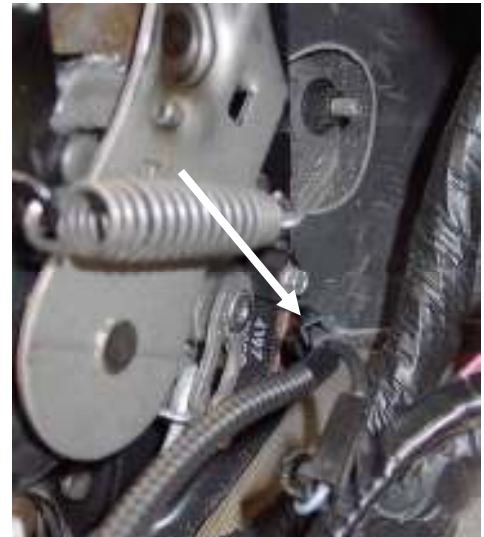

**Park Input Circuit** – Locate the 52-pin Chevrolet Body Control Module (BCM) connector # C2 located to the right and slightly below the hood release handle (see photo). Identify terminal 45 (light green wire). Connect the green wire from the ILIS main harness to this circuit by stripping the insulation, soldering, and taping. Do not cut the OEM Wire.

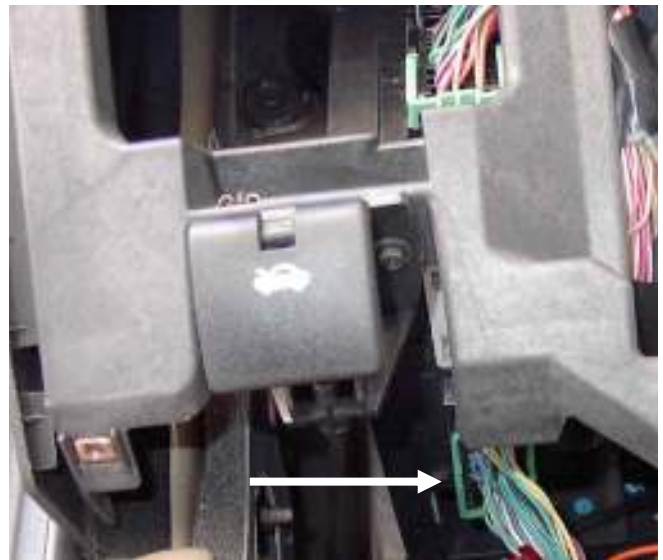
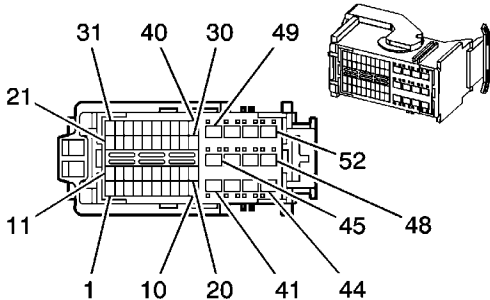

- White 4-Pin Connector** – This connector contains the lift power and lift door circuits. The mating harness is to be fabricated by the installer. The recommended mating connector is Molex Part # 0050841040. The recommended mating terminals are Molex Part # 0002081003. The recommended terminal extractor tool is Molex Part # 0011010168. The recommended hand crimp tool is Molex # 0638116800.

  - Lift Power Circuit** – Locate the lift power switch. Disconnect the circuit from the switch that goes to the lift relay. **Note: this must be a power switch, not a grounding switch.** Connect this circuit to the Blue/White wire from pin # 1 of the white 4-pin connector. Connect the Yellow wire from pin # 2 of the white 4-pin connector to the power switch. The lift power circuit must only activate the lift power relay/solenoid and must not draw more than 7.0 Amps. **Do not power any other loads (ie: lights, motors, etc.) off this circuit**
  - Lift Door Circuit** – **Note: the door switch must provide a ground with the door open. A switch that provides power with the door open will not operate correctly!** Locate the lift door switch circuit. Connect the Red/White wire from pin # 4 of the white 4-pin connector to this circuit.

**Park Output Circuit** – This is an optional circuit that provides a ground in Park gear only. This circuit is useful if the operator wishes to activate or deactivate an accessory only in Park (ie: power operated front door). Attach the **White** wire from the main harness to the ground side of the accessory. If this option is not desired, cut the wire at the 12-pin connector and discard the wire. **Note: This output can only carry low current loads such as a relay primary coil. Higher loads can cause damage to the control module. The current of the load must first be determined and can not exceed 500 milliamps continuous load. This wire must not be attached directly to power without a load, or damage to the control module will result.**

Finally, snap the 12-pin connector of the main wire harness into the control module. Make sure the connector is fully seated. Secure the control module on the metal support bracket behind the lower dash panel using 2-sided foam tape or wire ties.



**An ISO 9001:2000 Registered Company**

## **Post Installation Instructions ILIS 401/501/502/601/602/604**

Upon completion of installation of the Intelligent Lift Interlock System, the following procedure **MUST BE PERFORMED TO VERIFY PROPER INTERLOCK INSTALLATION AND FUNCTION:**

- Set Park Brake, place transmission to Park position, close lift door, and turn Lift Power Switch to the off position. Turn ignition to the “Run” position. Do not start vehicle.
- Verify LED prove-out on LED Status Panel
  - All five (5) LEDs should illuminate for approximately one (1) second upon initial power on.
- Verify that the Park LED, the Park Brake LED, and the Shift Lock LED remain illuminated.
- Place foot on service brake and attempt to shift out of Park. Shift lever should not be allowed to shift out of the Park position. If shift lever is allowed to move, check for loose connections at all connection points.
- Release Park Brake. Verify Park Brake LED and the Shift Lock LED on the LED Status panel are no longer illuminated. Remove foot from service brake and attempt to shift out of Park. Shift lever should not be allowed to shift out of the Park position. If shift lever is allowed to move, check for loose connections at all connection points.
- With Park Brake still released, place foot on service brake and attempt to shift out of park. Shift lever should now be allowed to shift out of Park position. Verify that all LEDs are not illuminated with transmission in any other gear. If shift lever is not allowed to move, check for loose connections at all connection points.
- Place shift lever back to the Park position and verify that the Park LED on the LED Status Panel is illuminated.
- With Park Brake still released, have an assistant open the lift door(s). Verify that the Lift Door LED and the Shift Lock LED on the LED Status Panel are now illuminated. Place foot on service brake and attempt to shift out of Park. Shift lever should not be allowed to shift out of “Park” position. If shift lever is allowed to move, check for loose connections at all connection points.
- Set Park Brake. Verify that the Park Brake LED on LED Status Panel is again illuminated. Turn on Lift Power Switch. Verify that the Lift Power LED on the LED Status Panel is now illuminated. All five (5) LEDs on the LED Status Panel should now be illuminated. Have assistant verify lift operation. Lift should now be operational.
- Release Park Brake. Verify that the Park Brake LED and Lift Power LED on the LED Status Panel are not illuminated. Have assistant attempt to operate lift. Lift should not be operational. If lift operates, check for loose connections at all connection points.
- If any irregular operational issues persist, contact InterMotive at 530-346-1801 for technical assistance.



---

An ISO 9001:2000 Registered Company

---

## **Intelligent Lift Interlock System (ILIS) – Operating Instructions**

The Intelligent Lift Interlock System (ILIS) is a microprocessor driven system for controlling wheelchair lift operation. Lift operation will only be allowed when all of the following conditions are met:

1. The vehicle is in “Park”
2. The parking brake is applied.
3. The vehicle ignition is on.
4. The lift power switch is on.
5. The lift door is open.

The Intelligent Lift Interlock System (ILIS) also will not allow the vehicle to be shifted out of park if the lift door is open. As an added feature, it also will not allow the vehicle to be shifted out of park anytime the parking brake is applied. This feature eliminates excessive parking brake wear due to driving with the parking brake applied.

When the vehicle is first started, or if the key is turned to the “Run” position the five LED’s on the display panel will illuminate for 1-2 seconds as a prove out of the LED’s. After prove out, the operation of the LED’s are as follows:

- Lift Power – Illuminates in green if power is available to the lift. This means that all conditions for lift operation have been met.
- Park Brake – Illuminates in red when the parking brake is applied.
- Park - Illuminates in red when the vehicle is in park range.
- Door Open - Illuminates in red when the lift door is open.
- Shift Lock - Illuminates in amber when the lift door is open and/or the parking brake is applied. If illuminated, the driver will not be allowed to shift out of park.

***All five LED’s must be illuminated for the lift to operate.***

The LED’s can also be used for diagnostic purposes. For example, if the Door Open LED is not illuminated when the lift door is open, the lift will not operate. This means that the ILIS module does not detect that the door is open. Thus, the technician should inspect the lift door switch and its circuit.

# REVISIONS

DATE : 7/18/07 CHANGE : ECN 2007-0002

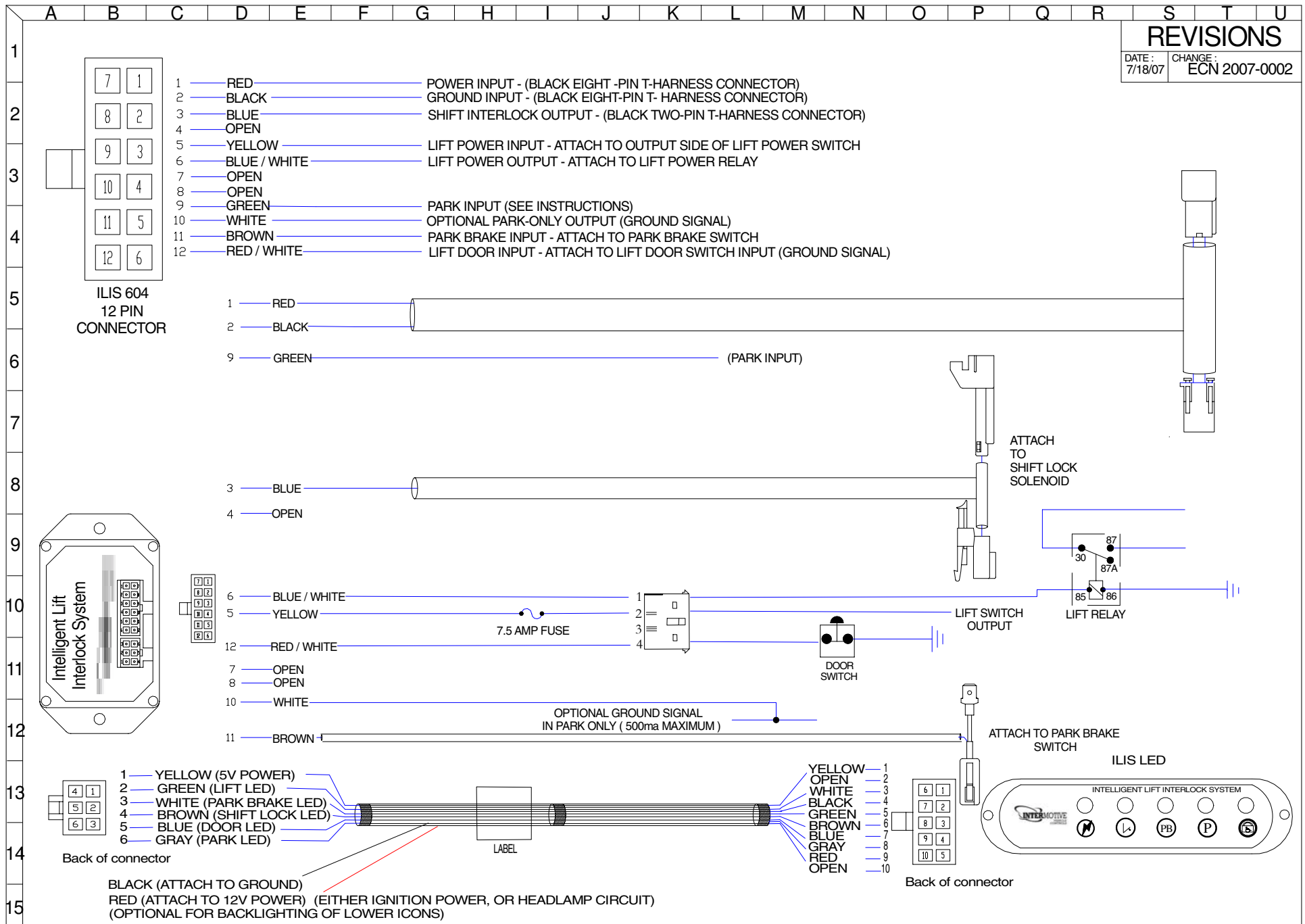

PRODUCT :

## INTELLIGENT LIFT INTERLOCK SYSTEM

DRAWN BY: Bruce Hodge

PART NO: ILIS 604 G

DATE DRAWN : 7/8/05

CHECK BY: Ed Prokopik

DATE CHECKED : 9/2/05