

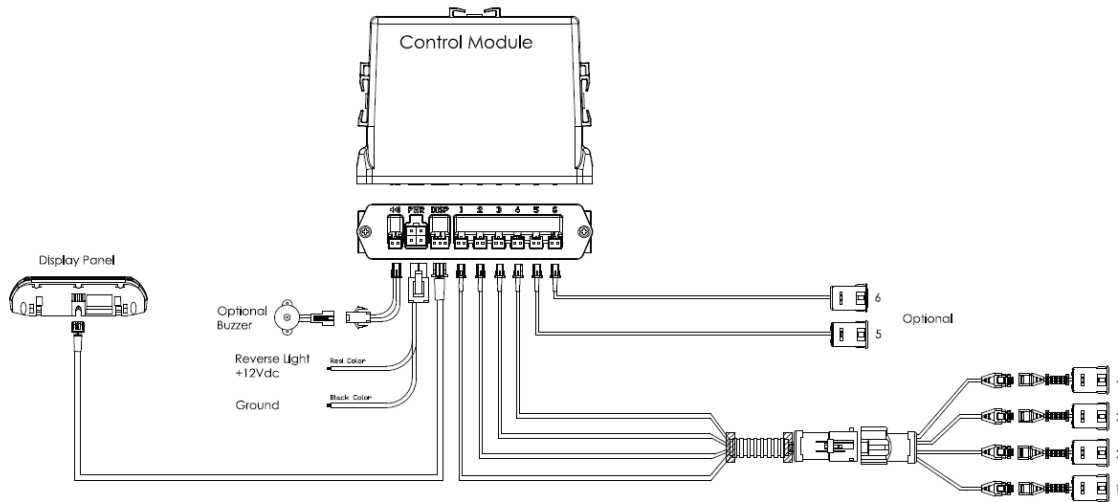

An ISO 9001:2008 Registered Company

Hawkeye^{Plus} Reverse Assistance System Installation Instructions



To aid in installation, first gain access to the connection points. Remove any interior panels covering the left (driver) side of the rear cap and along the upper left side of the vehicle all the way to the front of the vehicle. It is not necessary to cut any OEM wires during the installation of the Hawkeye^{Plus} wire harness.

SENSORS– The procedure for positioning and mounting the sensors depends on the shape of the rear bumper. The sensors must be mounted on a flat surface of the bumper (curved surfaces must not exceed 5°). Sensor height must be 17 – 24 inches from the ground or the sensors will not work properly.

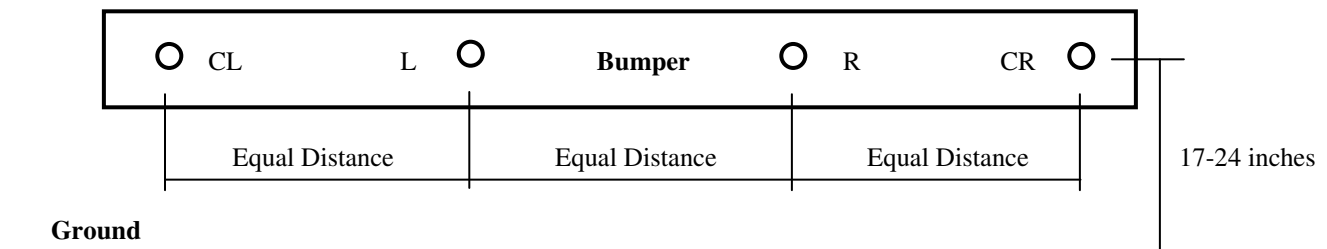

(Fig 1)

NOTE: The preset of the sensitivity for the sensor height is 17 inches above the ground. To avoid false alarm, sensor height must be at least 17 inches.

1. Measure horizontally from each corner of the bumper and mark a distance of 6 - 8 inches for both corner sensors (CL and CR).
2. Divide the remaining distance by 3 and mark the two center sensor locations such that the distance between each sensor is equal (see figure 1).
3. Drill four 1-inch holes (use a 1-inch hole saw) in the bumper through the previous marks.
4. Install the four sensors through the holes in their proper location. **THE SENSORS MUST BE INSTALLED WITH THE DOT POINTING DOWN.**

BUMPER/SENSOR HARNESS – The Bumper/Sensor Harness connects to each sensor and is attached to the bumper.

1. Lay out the Bumper/Sensor Harness along the back of the bumper. Position the connectors with green tape on right-hand (passenger) side of the bumper.
2. Connect each 2-pin connector from the sensors to the proper sensor. Make sure the connectors are fully seated and sealed.
3. Locate an appropriate position on the bumper for the gray 8-pin connector.
4. Drill a ¼” hole and mount the white retaining clip for the gray 8-pin connector.
5. Secure the harness as needed.

MAIN HARNESS – The Main Harness connects the Bumper/Sensor Harness to the Control Unit in the vehicle.

1. Connect the gray 8-pin connector on the Main Harness to the connector located on the bumper.
2. Drill a 5/8” hole in the bottom of the rear of the vehicle.
3. Route the harness through hole and seat the harness grommet securely in the hole.
4. Connect each of the four (4) white connectors to the proper openings on the Control Module. Make sure the connectors are fully seated.
5. Secure the harness as needed.

NOTE: Correct placement of the white connectors is critical for proper operation and diagnostics of the system.

CONTROL MODULE – The control module must be located inside of the vehicle on the left-hand (driver) side. Using the supplied mounting bracket and bolt/nut, attach the control module inside of the vehicle within four (4) feet of the rear tail-lamp assembly. The control module should be attached in a vertical position to prevent water from getting into the module.

CONTROL MODULE DIP SWITCHES - The default setting is switch 1 is On and switches 2-8 are Off. Switches 5-8 are resettable to change sensing distance from 7.0 to 5.5 feet. See (Fig. 4).

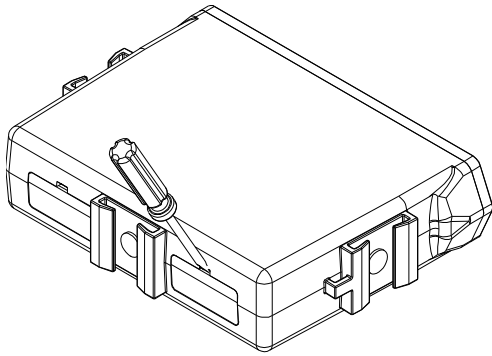

(Fig. 2)

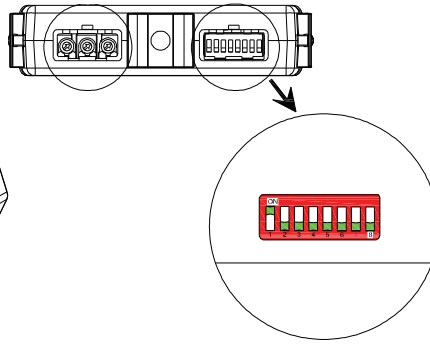

(Fig. 3)

Dip Switch	Setting	Note
1	On	Must be On
2	Off	Must be Off
3	Off	Must be Off
4	Off	Must be Off
5	Sensing Diagram - Refer to table in (Fig. 4)	Default is Type A - All Switches OFF
6		
7		
8		

Sensing Diagram

	Sensor #						Dip Switch Setting			
	1	2	3	4	5	6	5	6	7	8
Type A	Rear 7.0 Feet	Rear 7.0 Feet	Rear 7.0 Feet	Rear 7.0 Feet	-	-	OFF	OFF	OFF	OFF
Type B	Rear 5.5 Feet	Rear 5.5 Feet	Rear 5.5 Feet	Rear 5.5 Feet	-	-	OFF	OFF	OFF	ON

(Fig. 4)

LED DISPLAY PANEL – The LED Display Panel provides system feedback to the driver. Prior to installing the panel, determine if any changes to the default settings are desired. See (Fig. 6). If so, set switches as desired.

LED DISPLAY PANEL DIP SWITCH - The default setting is switches 1-6 are on, switches 7-8 are off.

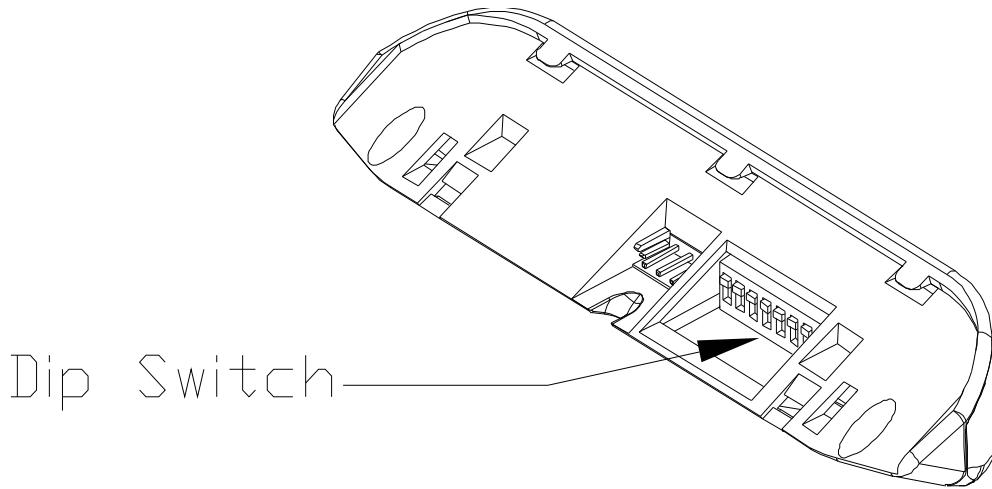

(Fig. 5)

Dip Switch	Function	Note
1	Power	Must be ON
2	Data	Must be ON
3	Buzzer	ON = activate buzzer OFF = no buzzer sound
4	Buzzer Volume 1	ON = louder OFF = does not affect the loudness of buzzer volume
5	Buzzer Volume 2	ON and Dip Switch 4 ON = loudest OFF = does not affect the loudness of buzzer volume
6	Feet/Meter	ON = Feet OFF = Meter
7	LED Bar Display Swap	ON = to swap the LED bar display for LEFT/RIGHT sensor indicator when the display is installed upside down
8	Number Display Rotation	ON = to invert the displayed number when the display is installed upside down

(Fig. 6)

Note: If mounting the LED panel in an inverted position, switches 7 and 8 must both be switched to "On" for proper readout.

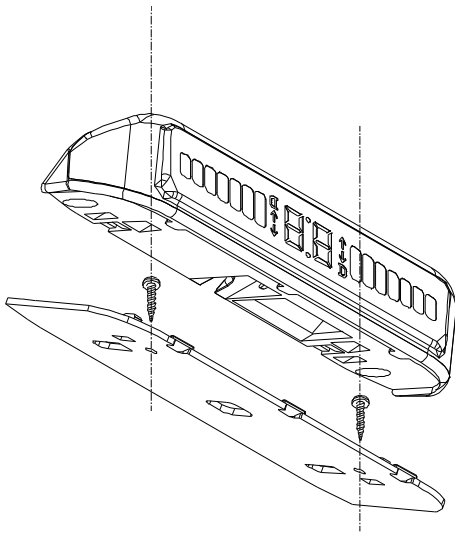

(Fig. 7a) Normal position.

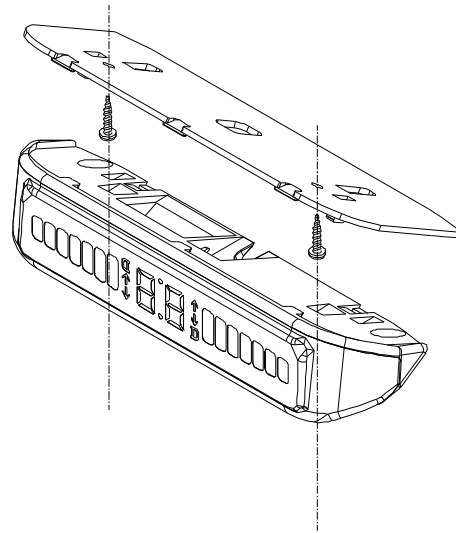

(Fig. 7b) Inverted position.

Mounting LED Panel

1. Using two of the supplied screws (different types are provided, but only two are needed), secure the display bracket (Fig. 7a or Fig. 7b), then attach the display to the bracket. If desired, drill a hole through the dash to route the display wire harness.
2. Run the display wire harness along the left (driver) side to the back of the vehicle.
3. Connect the white 3-pin connector to the proper opening on the control module. Make sure the connector is fully seated.
4. Secure the harness along the left side of the coach.

POWER/GROUND HARNESS – The Power/Ground Harness provides power to the Control Module when the transmission is placed in reverse.

1. Verify that chassis ignition power is OFF.
2. Locate the OEM circuit that provides power to the reverse lamp in the rear tail-lamp assembly. Connect the red wire from the Hawkeye ^{Plus} Power/Ground Harness to this circuit. Note: if using an external rear backup alarm, do not attach the Hawkeye ^{Plus} red wire to the same side tail-lamp wire as the backup alarm or it may interfere with the Hawkeye ^{Plus} operation. Example: If the external backup alarm gets power from the right tail-lamp wire, the Hawkeye ^{Plus} red wire must be attached to the left side tail-lamp wire.
3. Connect the ground eyelet to a known good ground point near the tail lamp assembly.
4. Connect the white 4-pin connector to the proper opening on the control module. Make sure the connector is fully seated.
5. Secure the harness as needed.

POST-INSTALLATION TESTING

IMPORTANT: Ensure no objects are present within 10 feet of the bumper while testing.

1. Verify that the park brake is firmly set. Turn the ignition key to “ACC” position and place the transmission in reverse. The display indicator should activate and produce a single audible beep.
2. With the aid of an assistant, verify that the corner sensors are connected into the proper openings on the Control Module:
 - 2.1 Use a cloth to cover the two middle sensors. Holding a flat dense object (5” x 20”), approach the Passenger side corner (#4) sensor from approximately 7.0 feet away. Verify that the LED Display shows proper distance and orientation. Repeat procedure for the driver side corner (#1) sensor
 - 2.2 Remove covers from the middle sensors and block the corner sensors. Repeat procedure as in 2.1. Verify that the LED Display shows proper distance and orientation.
3. If the system gives a warning without an object in the proper zone (false alarm):
 - 3.1 Check for proper sensor installation and orientation (dot on sensor must be facing down).
 - 3.2 The sensors may be detecting the ground. NOTE: The preset of the sensitivity for the sensor height is 17 inches above the ground. To avoid false alarm, sensor height must be at least 17 inches. If sensor height is correct, adjust sensitivity (see next page).

SYSTEM SELF TEST

Immediately after the system powers up (when vehicle is shifted into reverse), it will do a sensor self test. If a sensor circuit is malfunctioning, or a sensor is disconnected, the corresponding sensor # will be displayed briefly on the LED display. That corresponding sensor circuit should be inspected. The sensor circuits are labeled numerically at the back of the control module. On the bumper, the outermost sensor on the driver side is sensor #1, then proceeding towards the passenger side, #2, #3, and finally #4 which is the outermost sensor on the passenger side of the bumper.

Sensor Malfunction or No-connect Visual Display Status

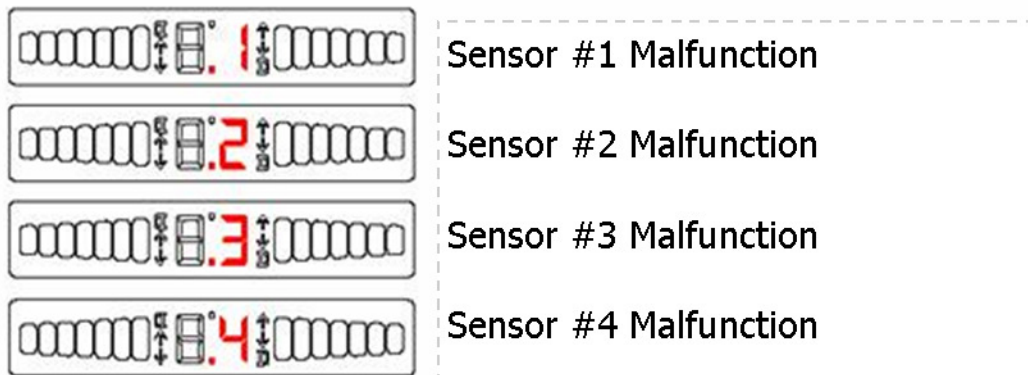

GUIDE TO ADJUST SYSTEM SENSITIVITY (POTENTIOMETER # 1 ONLY)

NOTE: Potentiometer # 2 and potentiometer# 3 are currently used.



not

1. Open the control module cover using a screw driver (see Fig. 2)
2. Use a cart or other mobile object with a piece of 3/4" plywood (18"x24") on the side facing the sensors (Fig. 8). A dense material is required to reflect the ultra sonic waves.
3. Position the cart in the direct path of a sensor at the distance of five feet. (Fig. 8)
4. Insert a small screwdriver into the # 1 potentiometer and gently turn the potentiometer clockwise to the stopping point.

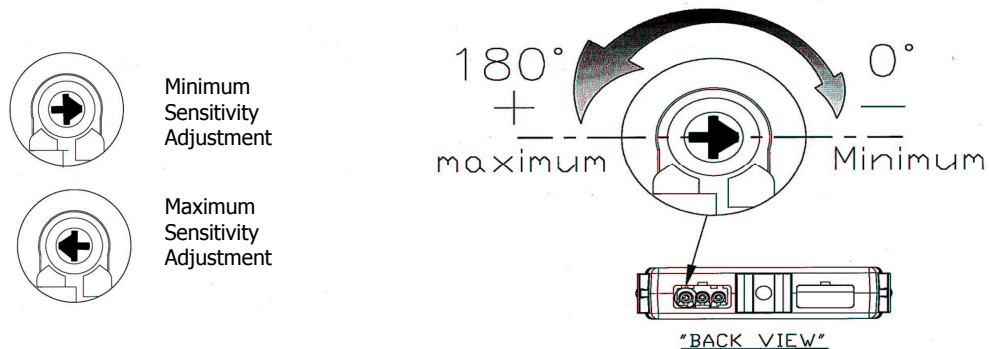

(Fig. 9)

5. Set the park brake, block the wheels and place the transmission in reverse. The display panel should now have a blank reading.
6. Slowly turn the potentiometer counter-clockwise until the display gives a numerical reading of the distance of the cart and has a consistent audible sound.
7. Reset the module by placing the vehicle in park or by unplugging the module power connector. Removing the power from the module allows the module to recognize the new sensitivity adjustment.
8. Place vehicle in reverse or reinstall the module power connector. Move the cart away from the bus and note the display readings. Move the cart forward, measure the cart distance and compare the distance with the display reading.
9. Adjust the sensitivity further if needed. Turning the potentiometer clockwise reduces the sensitivity and turning the potentiometer counter-clockwise increases sensitivity. Note: newer modules have increased sensitivity and allow 180° of adjustment. Newer modules can be identified by a blue dot on the connector side of the black plastic housing. (see Fig.9).
10. Repeat Post-Installation Testing. If necessary, readjust and retest.
11. Replace cover on the back of the Control Module.

CAUTION!

This system is not designed to prevent contact with small or moving objects. This system is designed to provide a warning to assist the driver in detecting large stationary objects when moving in reverse at “parking speeds” of approximately 4 mph. The Hawkeye^{Plus} Reverse Assistance System may have reduced performance or be activated in inclement weather.

To help avoid personal injury, always use caution when in reverse and when using the Hawkeye^{Plus} Reverse Assistance System.



13395 New Airport Rd
Auburn, CA 95602
530-823-1048 Phone
530-823-1516 Fax
www.intermotive.net