



An ISO 9001:2000 Registered Company

Guardian II Commercial Lift Interlock (GRD602-A)

Installation Instructions

Application

**Chevy Full Size Van (GMT 610) – 2003-2007
2001-2002 Requires Auxiliary Kit # GRDC1**

GUARDIAN II MODULE - Remove the lower dash panel below the steering column. The Guardian II Module should be positioned behind the metal knee bolster bracket below the steering column. It can be secured using self tapping screws, adhesive foam tape, or wire ties. Do not secure the module until all harnesses are installed and proper lift operation has been verified.

LED DISPLAY PANEL – This harness can be identified by the blue tape near the 6-pin connector. Locate a suitable position on the dashboard, within view of the driver, for the mounting of the LED Display Panel. The length of the display harness is 40". This is the maximum distance the display can be from the Guardian II Module. Drill a 3/4" hole in the dashboard where you wish the center of the display to be. Snap the blue taped end of the LED display harness into the Guardian II Module in the connector labeled in blue "Display". Either end of the harness can be used. Run the other end of the harness under the dash and out through the 3/4" hole. Snap the end of the display harness into the LED Display Panel. Ensure panel is level, and secure using the supplied screws.



LIFT HARNESS - This harness can be identified by the green tape near the 6-pin connector. Attach the red wire with the inline fuse to the vehicle battery positive post. There is a large eyelet taped to the fuse holder that can be used for this purpose. Attach the black wire with the eyelet to a good ground point. Run the gray cable back towards the lift. The black wire in the gray cable will attach to the lift door switch. This switch must provide a ground only when the lift door is **open**. Attach the red wire in the gray cable to the interlock input to the lift. This wire will provide 12V to the lift when all interlock conditions are met. Maximum current for this circuit is 8A. The interlock inputs on FMVSS 403/404 compliant lifts are as follows:

Ricon – Red wire to Pin 7 of 9-pin connector (Ricon Part # 32753).
Braun –Red wire to Pin 6 of 9-pin connector (Grey/Red wire).
Maxon –Red wire to white/red wire on Maxon lift.

For non FMVSS 403/404 compliant lifts, consult the lift manufacturer for proper hookup.

Finally, snap the green-taped end of the harness into the connector labeled in green “Lift” on the Guardian II Module.



Before continuing installation, the following check must be performed:

Verify that the vehicle ignition is off and the lift door is fully closed for at least 5 minutes. This will ensure the Guardian II module is in sleep mode. Open the lift door. All three indicators on the LED Display Panel should briefly illuminate as a prove-out after the module wakes up. If they do not, check to make sure each harness is connected to the proper Guardian II Module connector as outlined in the above steps. Only proceed to the next step if the indicators illuminate. Otherwise, damage can occur to the module.

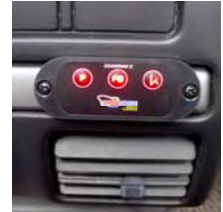

VEHICLE HARNESS -

2003-2007 models only! 2001-2002 models require Auxiliary Kit # GRDC1. Do not install the wrong application harness or damage to vehicle will result!

Gray 6-Pin Connector – Disconnect the gray, 6-pin Chevrolet connector located behind the left side of the lower dash panel directly behind the park brake release handle. (See below item 1). Separate the Chevrolet connector and plug the Guardian II 6-pin connector between the two ends of the Chevrolet connector.

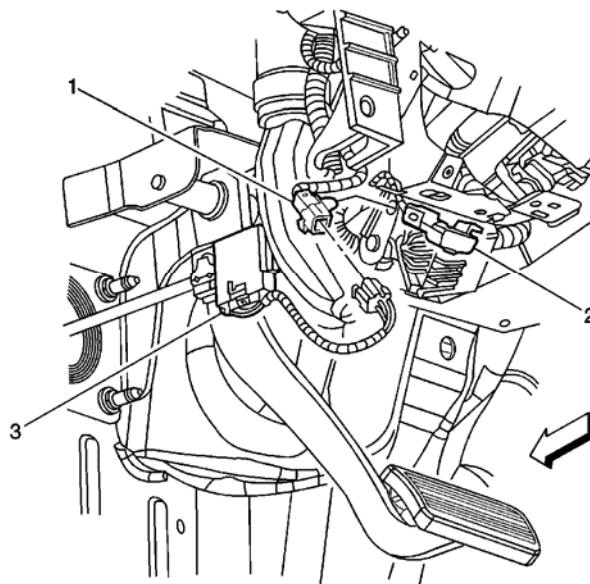

Park Brake Connector – Disconnect the black, single-wire Chevrolet connector from the park brake switch. Plug the female side of the Black connector from the Guardian II Vehicle harness to the parking brake. (See below item 1). Install the male spade side to the female connector in the Chevrolet harness. (See below item 2).

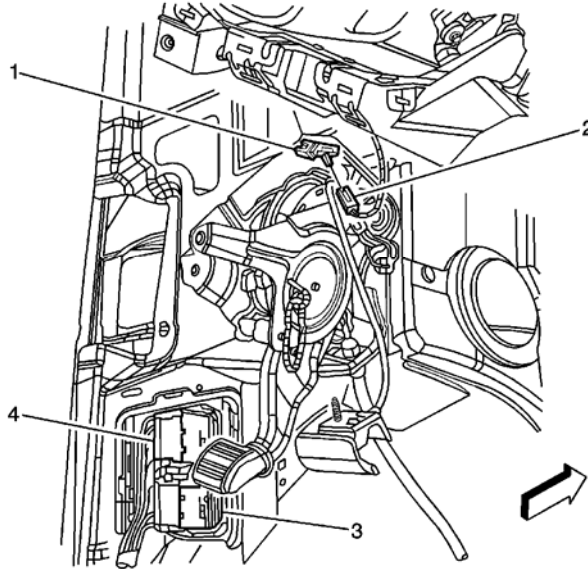

Finally, plug the orange taped 6-pin connector into the Guardian II Module in the connector labeled in orange “Vehicle 1” and plug the 4-pin connector into the connector labeled in white “Vehicle 2”.



Secure the Guardian II Module in its final location and test for proper operation. (See Post Installation Check List).





An ISO 9001:2000 Registered Company

Guardian II Commercial Mobility Lift Interlock (GRD502-A/602-A)

Post Installation Check List

The following checks must be made after installation of the InterMotive Guardian GRD502 or GRD602 to ensure correct and safe operation of the lift. If any of the checks do not pass, do not deliver the vehicle. Recheck all connections as per the installation instructions.

Begin the checklist with the vehicle in the following state:

- Lift stowed
- Park brake set
- Transmission in park
- Ignition off
- All Guardian LED's not illuminated (sleep mode)
- Lift access door closed

1. Turn on the ignition. Verify that all three LED's prove out and the Park (P) and Park Brake (PB) icons remain illuminated.
2. Attempt to deploy the lift. The lift must not deploy.
3. Release the park brake and open the lift access door. The Park Brake (PB) icon should now be off and the lift access door icon should be illuminated.
4. Attempt to deploy the lift. The lift must not deploy.
5. Attempt to shift the transmission out of park. The transmission shift lever must not be able to shift.
6. Set the park brake. All three icons should now be illuminated.
7. Attempt to deploy the lift. The lift should deploy.
8. With the lift deployed, attempt to shift the transmission out of park. The transmission shift lever must not be able to shift.
9. Stow the lift and close the lift access door. The Lift Access Door Open icon should now be off.
10. Turn off ignition.
11. Wait approximately 5 minutes for the module to enter "sleep mode." This is verified when all LED's turn off.
12. Open the lift access door. The module should prove-out all three LED's and the LED's should remain illuminated. The lift should be able to deploy. Deploy the lift.
13. Stow the lift and close the lift access door. Installation is complete.



An ISO 9001:2000 Registered Company

Guardian II Commercial Lift Interlock (GRD502-A/602-A)

Operating Instructions

The Guardian II is a microprocessor driven system for controlling wheelchair lift operation. Lift operation will only be allowed when all of the following conditions are met:

1. The vehicle is in "Park".
2. The parking brake is applied.
3. The lift door is open.

The Guardian II also will not allow the vehicle to be shifted out of park if the lift door is open or the parking brake is engaged.

The Guardian II will operate with the vehicle ignition on or off. When the ignition is turned on or the lift door is opened, the LED panel will prove out by illuminating the three red indicators briefly. When the lift door is closed and ignition power is not present for 5 minutes, the Guardian II will enter a low current "sleep" mode of operation. To wake up from "sleep" mode, the ignition must be turned on or the lift door must be opened. After prove out, the operation of the indicators is as follows:

- "P" - Illuminates in red if vehicle is in Park range.
- "PB" - Illuminates in red when the parking brake is engaged. If illuminated, the driver will not be allowed to shift out of park.
- "Lift Door Open Icon" – Illuminates in red when the lift door is open. If illuminated, the driver will not be allowed to shift out of park.

The Lift will only operate if all three LED's are simultaneously illuminated.

The indicators can also be used for diagnostic purposes. For example, if the Lift Door Open icon is illuminated when the lift door is closed, the driver will not be able to shift out of park. This means that the Guardian II detects that the lift door is open. Thus, a technician should inspect the lift door switch and its circuit for proper operation.

REVISIONS

DATE :	CHANGE :
11/9/07	Rev B

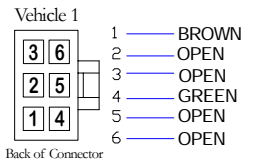

- 1 — BROWN (Park Brake Signal)
- 2 — OPEN (Not Used)
- 3 — OPEN (Not Used)
- 4 — GREEN (Park Signal)
- 5 — OPEN (Not Used)
- 6 — OPEN (Not Used)

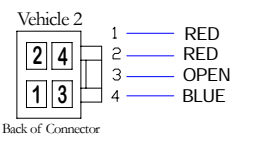

- 1 — RED (Ignition Power)
- 2 — RED (Ignition Power)
- 3 — OPEN (Not Used)
- 4 — BLUE (Shift Lock Out)

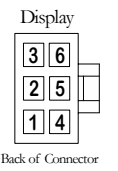

- 1 — YELLOW (5 V)
- 2 — WHITE (Door Open LED)
- 3 — BLACK (Park Brake LED)
- 4 — BROWN (Not Used)
- 5 — BLUE (Park LED)
- 6 — RED (Not Used)

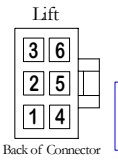

- 1 — RED (Lift Power Out-12V)
- 2 — BLACK (Lift Door In - Ground)
- 3 — YELLOW (Battery Power)
- 4 — BLACK (Ground)
- 5 — OPEN (Not Used)
- 6 — RED (Battery Power)

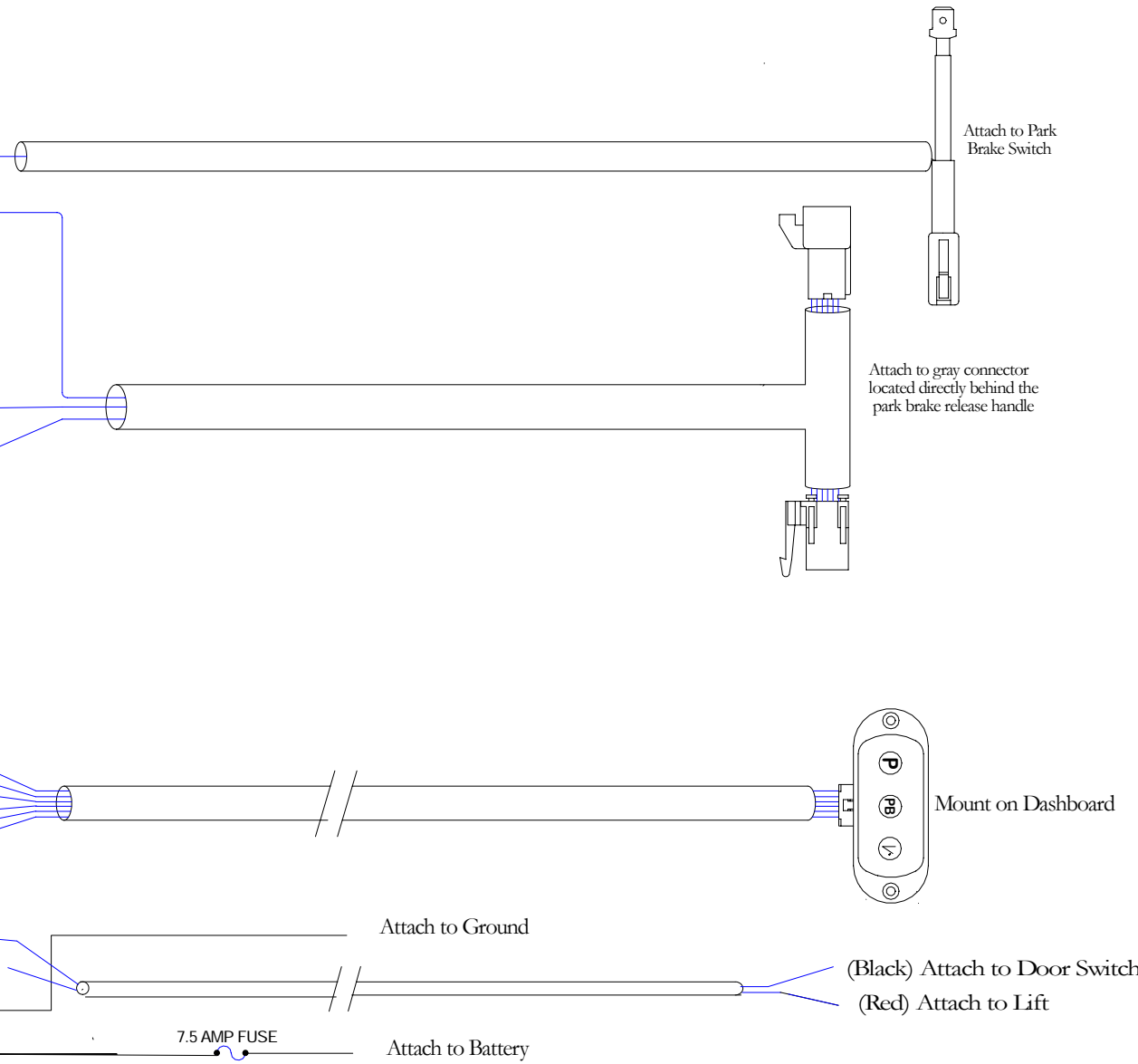
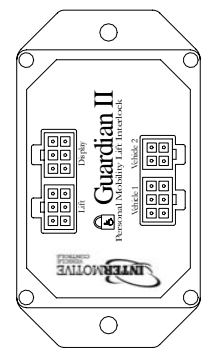

PRODUCT: Chevy Guardian II

DRAWN BY:	Bruce Hodge	PART NO.:	GRD602-A
DATE DRAWN:	6/6/05	CHECK BY:	Ed Prokopik
		DATE CHECKED:	6/6/05