



Guardian I 501-BB/BR/BG - Symptom Flow Chart

Condition	Possible Cause	Action
•No prove out of any LEDs	•Connections •LED Panel •Harness(es) •Power •Ground •Module	•Go to Pinpoint Test A
•LED Indicators Alternate (LED's lighting up one after another.)	•Connections •Module •Harness(es)	•Go to Pinpoint Test B
•All LED's Flash	•Connections •Harness(es) •Current Draw of Lift •Module Revision	•Go to Pinpoint Test C
•One or More LED's not illuminated, when condition(s) met	•Connections •Lift Power •Lift not Stowed •Harness(es) •Module	•Go to Pinpoint Test D
•LED's properly illuminated, but lift not operating	•Connections •Harness(es) •Lift •Module	•Go to Pinpoint Test E
•Lift Operates when Safety Conditions Not Met	•Connections •Harness(es) •Module •Lift	•Go to Pinpoint Test F
•Lift Operates Intermittently	•Connections •Harness(es) •Lift •Module	•Go to Pinpoint Test G
•Shifter Never Locks	•Connections •Module •Lift stowed signal •Harness(es) •OEM - shift lock solenoid	•Go to Pinpoint Test H
•Cannot Shift Out of Park	•Connections •OEM - shift lock solenoid •Lift stowed circuit •Harness(es) •Module	•Go to Pinpoint Test J
•Some, but not all, Display Panel LED's Do Not Prove Out Properly	•Connections •LED Display Panel •Harness(es) •Module	•Go to Pinpoint Test K

The following items are necessary for proper diagnosis:

Digital Multimeter (Do Not Use A Test Lamp)
 Inductive Ammeter, capable of measuring down to 0.1 amps DC
 Guardian 501-BB/BG/BR documentation
 (Available at www.intermotive.net) 02/05/09

PINPOINT TEST A: NO PROVE OUT OF ANY LEDs

No prove out (all LED's light up) of the LED's when module power is applied or module "wakes up", indicates that:
 - the Guardian module does not have power.
 - the LED display or harness damaged.

Estimated Time To Complete: 12 Minutes

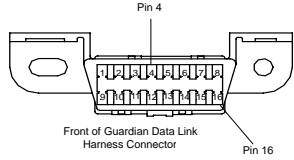
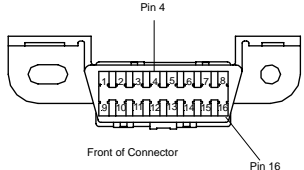
Test Step	Result/Action to Take
<p>A1 Ensure that all connectors are installed correctly</p> <ul style="list-style-type: none"> Carefully inspect module and harness(es). Refer to schematics in Guardian documentation to verify correct harness connector is in the correct module plug. <p>• Are all harness connectors properly installed into module?</p>	<p>Results _____</p> <p>Yes Go to A2</p> <p>No Review install instructions, reinstall all connectors in their proper position. Test system for normal operation.</p>
<p>A2 Check voltage at "Data Link 1" connector at the module.</p> <ul style="list-style-type: none"> Using a Digital Multimeter measure voltage by back probing the Data Link 1 connector. Measure the voltage by back probing the Data Link 1 connector Pin # 1 Red wire (Red Digital Mutimeter test lead) and Ground (Black Digital Mutimeter test lead).  <p>• Is the voltage greater than 11.5 Volts?</p>	<p>Results _____</p> <p>Yes Go to A6</p> <p>No go to A4</p>
<p>A4 Check the voltage at Guardian's Data Link Connector (DLC)</p> <ul style="list-style-type: none"> Using a Digital Multimeter, measure voltage between pin 16 (Red Digital Mutimeter test lead) and pin 4 (Black Digital Mutimeter test lead) of Data link connector.  <p>• Is the voltage greater than 11.5 Volts?</p>	<p>Results _____</p> <p>Yes Contact InterMotive for assistance with the InterMotive Data Link harness.</p> <p>No Go to A5</p>
<p>A5 Check the voltage at Data Link Connector (DLC)</p> <ul style="list-style-type: none"> Disconnect Guardian Data link harness from the OEM Data Link connector. Measure the voltage at OEM Data link connector between pin 16 (Red Digital Mutimeter test lead) and pin 4 (Black Digital Mutimeter test lead).  <p>• Is the voltage greater than 11.5 Volts?</p>	<p>Results _____</p> <p>Yes Contact InterMotive for assistance with the InterMotive Data Link harness</p> <p>No Check the OEM fuse for the DLC (Data Link Connector). If the DLC fuse is okay, contact OEM dealer for OEM electrical system service.</p>

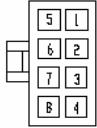
Test Step	Result/Action to Take
A6 Check voltage from the module at the "LED" connector <ul style="list-style-type: none"> At the Guardian module, Back probe the connector labeled "LED". Using a Digital Multimeter, measure voltage between "LED" connector pin #1 Yellow wire (Red Digital Mutimeter test lead) and Ground (Black Digital Mutimeter test lead).  <p style="text-align: center;">"LED" connector receptacle</p> <ul style="list-style-type: none"> Is the voltage greater than 4.5 Volts? 	<p style="text-align: center;">Results _____</p> <p>Yes Go to A7</p> <p>No Contact InterMotive for assistance with Guardian module</p>

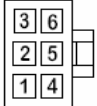
Test Step	Result/Action to Take
A7 Check voltage at "LED" display connector <ul style="list-style-type: none"> Using a Digital Multimeter, measure voltage at the "LED" Display connector. Back probe the "LED" Display connector Pin #1 Yellow wire (Red Digital Mutimeter test lead) and Ground (Black Digital Mutimeter test lead) .  <p style="text-align: center;">Back of Harness connector at the display panel</p> <ul style="list-style-type: none"> Is the voltage greater than 4.5 Volts? 	<p style="text-align: center;">Results _____</p> <p>Yes Contact InterMotive for assistance with LED Panel.</p> <p>No Contact InterMotive for assistance with the "LED" Display harness</p>

PINPOINT TEST B: LED INDICATORS ALTERNATE
Alternating LED's (LED's lighting up one after another) indicates that:
- the Guardian module cannot communicate with the OEM vehicle communications network

Estimated Time To Complete: 12 Minute:

Test Step	Result/Action to Take
B1 Ensure that all connectors are installed correctly <ul style="list-style-type: none"> Carefully inspect module and harness(es). Verify correct harness connector in the correct module plug. Refer to schematics in Guardian documentation. <ul style="list-style-type: none"> Are all harness connectors properly installed into module? 	<p style="text-align: center;">Results _____</p> <p>Yes Go to B2</p> <p>No Review install instructions, reinstall all connectors in their proper positions. Test system for normal operation.</p>

Test Step	Result/Action to Take
B2 Ensure that all wires are in their correct connector cavity <ul style="list-style-type: none"> Carefully inspect all harness connectors. Verify that each connector has the correct wires in the correct connector pin cavity. Refer to schematics in Guardian documentation for wire colors and pin locations. <ul style="list-style-type: none"> Are all wires secure, and in their correct connector pin cavity? 	<p style="text-align: center;">Results _____</p> <p>Yes Go to B3</p> <p>No Contact InterMotive for assistance with harness and connectors</p>

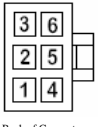
Test Step	Result/Action to Take
B3 Check for data communication <ul style="list-style-type: none"> At the Guardian module, Back probe the connector labeled "Data Link 1". Using a Digital Multimeter, measure voltage the at Pin # 3 Yellow wire (Digital Multimeter Red Lead) at the back of the harness connector and (Digital Multimeter Black Lead) chassis ground, and between pin # 6 Brown wire (Digital Multimeter Red Lead) at the back of the harness connector and (Digital Multimeter Black Lead) chassis ground.  <p style="text-align: center;">Back of Connector Data Link 1</p> <ul style="list-style-type: none"> Are the two voltage readings 2.4-2.6 Volts? 	<p style="text-align: center;">Results _____</p> <p>Yes Go to B6</p> <p>No Go to B4</p>

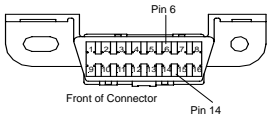
Test Step	Result/Action to Take
B4 Check voltage at Guardian's Data Link Connector (DLC). <ul style="list-style-type: none"> Measure voltage at data link connector between pin 6 and chassis ground and between pin 14 and chassis ground.  <p style="text-align: center;">Front of Connector</p> <ul style="list-style-type: none"> Are both voltage readings 2.4-2.6 Volts? 	<p style="text-align: center;">Results _____</p> <p>Yes Contact InterMotive for assistance with the InterMotive Data Link harness</p> <p>No Go to B5</p>

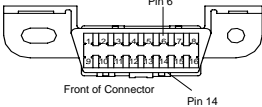
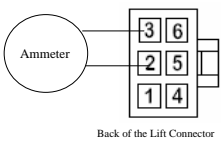

Test Step	Result/Action to Take
<p>B5 Check voltage at the OEM Data Link Connector.</p> <ul style="list-style-type: none"> Disconnect Guardian's Data Link Connector (DLC) T harness from the OEM data link connector, measure voltage at the OEM data link connector between pin 6 and chassis ground and between pin 14 and chassis ground.  <ul style="list-style-type: none"> Are both voltage readings 2.4-2.6 Volts? 	<p>Results_____</p> <p>Yes Contact InterMotive for assistance with the InterMotive Data Link harness</p> <p>No Contact OEM dealer</p>
<p>B6 Check for CAN-Communication</p> <ul style="list-style-type: none"> Disconnect Guardian's Data Link Connector (DLC) "T" harness from OEM data link connector. Using a Scan Tool, or InterMotive "Canalyzer", insert into OEM data link connector, attempt to communicate with the PCM by retrieving fault codes or reading data. <ul style="list-style-type: none"> Is communication with PCM successful? 	<p>Results_____</p> <p>Yes Contact InterMotive for assistance with the InterMotive Data Link harness</p> <p>No Contact OEM dealer for network communication concerns</p>
<p>PINPOINT TEST C: All LED'S FLASH</p> <p>Flashing of the LED indicators on the LED display indicates that:</p> <p>-there is excessive current draw on the lift output circuit</p> <p>Estimated Time To Complete: 12 Minutes</p>	
Test Step	Result/Action to Take
<p>C1 Ensure that all connectors are installed correctly</p> <ul style="list-style-type: none"> Carefully inspect module and harness(es) Verify correct harness connector in the correct module plug Refer to schematics in Guardian documentation <ul style="list-style-type: none"> Are all harness connectors properly installed into module? 	<p>Results_____</p> <p>Yes Go to C2</p> <p>No Review install instructions, reinstall all connectors in their proper positions. Test system for normal operation.</p>
Test Step	Result/Action to Take
<p>C2 Ensure that all wires are in their correct connector cavity</p> <ul style="list-style-type: none"> Carefully inspect all harness connectors Verify that each connector has the correct wires in the correct connector pin cavity Refer to schematics in Guardian documentation for wire colors and pin locations <ul style="list-style-type: none"> Are all wires secure, and in their correct connector pin cavity? 	<p>Results_____</p> <p>Yes Go to C3</p> <p>No Contact InterMotive for assistance with harness and connectors</p>
Test Step	Result/Action to Take
<p>C3 Check for over current condition</p> <ul style="list-style-type: none"> Disconnect 6-pin "Lift" connector at the module. Using a jumper wire of 18 gauge or larger, jumper the RED wire PIN # 3 to the GREEN wire pin # 2 at the back of the 6-pin "LIFT" harness connector. (This jumper is used to temporarily bypass Guardian operation to check lift operation). Place an inductive ammeter, capable of measuring down to 0.1 amps DC, around the jumper wire. (An inductive ammeter should be used since most internal shunt ammeters cannot handle amperages exceeding 10 amps without meter damage). Activate lift. <p>NOTE: If the meter is hooked up properly, there should be a reading of more than 0.0 Amps with the lift operating.</p> <ul style="list-style-type: none"> Is the current draw greater than 10 amps during lift activation? 	 <p>Results_____</p> <p>Yes It will be necessary to install a relay on the lift output circuit.</p> <p>No Contact InterMotive for assistance with Guardian module.</p>

PINPOINT TEST D: ONE OR MORE LEDS NOT ILLUMINATED, WHEN CONDITION(S) MET

If a LED indicator fails to light when its associated condition(s) are met:

- there is a problem with an input and/or input circuit.
- there is a problem with the OEM electrical system.
- the Guardian module may have an issue.

Estimated Time To Complete: 18 Minutes

Test Step	Result/Action to Take
<p>D1 Ensure that all connectors are installed correctly.</p> <ul style="list-style-type: none"> Carefully inspect module and harness(es). Verify correct harness connector in the correct module plug. Refer to schematics in Guardian documentation. <p>• Are all harness connectors properly installed into module?</p>	<p>Yes Go to D2.</p> <p>Results _____</p> <p>No Review install instructions, reinstall all connectors in their proper position. Test system for normal operation.</p>
<p>D2 Ensure that all wires are in their correct connector cavity</p> <ul style="list-style-type: none"> Carefully inspect all harness connectors Verify that each connector has the correct wires in the correct connector pin cavity Refer to schematics in Guardian documentation for wire colors and pin locations <p>• Are all wires in their correct connector pin cavity?</p>	<p>Results _____</p> <p>Yes Go to D3</p> <p>No Contact InterMotive for assistance with harness and connectors</p>
<p>D3 Check LED indicators</p> <p>Reminder: Prove out of LED's on the display panel (all status indicator LED's light up) occurs whenever the module comes out of "Idle Mode" or power is initially applied. The icons do not light up until after the status indicator LED's prove out.</p> <ul style="list-style-type: none"> Disconnect the "Data Link 1" connector briefly, then reconnect it, to initiate LED prove out. <p>• Do all LED's on the display panel light up during the prove out cycle after "Data Link 1" is reconnected?</p>	<p>Results _____</p> <p>Yes Go to D4</p> <p>No Go to K3</p>
<p>D4 Observe LED display panel</p> <p>Note: Please review system operation before trying to identify faulty status indicator LED operation.</p> <ul style="list-style-type: none"> Key in the ON position. Perform each function; set park brake, transmission in PARK, move lift away from it's "stowed" position. <p>• Which Status Indicator LED does not illuminate properly (stays off with conditions met, or always on)?</p> <p>Reminder: The icons on the display panel should be backlit whenever the ignition key is on and after status indicator LED prove out. The sole purpose of the icons is to identify the status indicator LED's located directly above each icon.</p>	<p>Results _____</p> <p> Vehicle Secure LED - Go to D5</p> <p> Lift Not Stowed LED - Go to D7</p>

Test Step	Result/Action to Take
<p>D5 Check park brake operation</p> <ul style="list-style-type: none"> • Key in the ON position • Alternately release and apply the parking brake. • Back probe "Park Brake" connector, to check voltage from Pin #3 (Digital Multimeter Red Lead) to Ground (Digital Multimeter Black Lead). <p>• Does the voltage alternate between 0v and 11.5v? (0v with Park Brake applied.)</p>	<p>Results_____</p> <p>Yes GO to D6.</p> <p>No Contact OEM dealer or check park brake switch and circuits.</p>
<p>D6 Check park operation</p> <ul style="list-style-type: none"> • Verify that the vehicle transmission range selector is in the PARK position. • Using a scan tool, monitor the transmission range sensor data. <p>• Does the gear selector correlate to the Transmission Range sensor data on scan tool?</p>	<p>Results_____</p> <p>Yes Contact InterMotive for assistance with Guardian module.</p> <p>No Contact OEM dealer concerning Transmission Range sensor and network communication issues</p>
<p>D7 Check lift stowed switch circuit operation</p> <ul style="list-style-type: none"> • Using a Digital Multimeter, measure the voltage from the back of pin #5 (Brown wire) at the connector labeled "Lift" on the Guardian Module to chassis ground. • Alternately activate and deactivate the lift stowed switch by moving the lift appropriately. <div data-bbox="592 653 690 766" style="text-align: center;"> <p>Back of the Lift Connector</p> </div> <p>• Does the voltage on pin #5 measure higher than 4.5 Volts with the lift not stowed, then drop to less than 0.2 Volts with the lift stowed?</p>	<p>Results_____</p> <p>Yes Contact InterMotive for assistance with Guardian module.</p> <p>No The voltage does not change when the lift is stowed or not - Go to D8.</p>
<p>D8 Check lift stowed switch circuit operation</p> <ul style="list-style-type: none"> • Move lift away from stowed position. • Disconnect the "Lift" connector at the Guardian Module. • With the Digital Multimeter set to resistance, measure between the "Lift" harness Pin #5 and chassis ground. • Activate Lift Stowed switch by hand. <div data-bbox="592 968 690 1081" style="text-align: center;"> <p>Back of the Lift Connector</p> </div> <p>• Does resistance alternate between ∞ (open) and closed?</p>	<p>Results_____</p> <p>Yes - Lift stowed switch needs adjustment.</p> <p>No - The resistance stays high (Open) - Go to D9 The resistance stays low (Short) - Go to D10</p>
<p>D9 Check lift stowed switch circuit operation</p> <ul style="list-style-type: none"> • Disconnect the connector labeled "Lift" on the Guardian module (leave all other connectors in place). • Using a Digital Multimeter, in resistance mode, measure the resistance between the "Lift" harness Pin #5 and the wire connection at the lift stowed switch. (Not the chassis ground wire.) <div data-bbox="592 1291 690 1404" style="text-align: center;"> <p>Back of the Lift Connector</p> </div> <p>• Is the resistance near 0 ohms?</p>	<p>Results_____</p> <p>Yes Lift stowed switch needs replacing.</p> <p>No Contact InterMotive for assistance with Guardian harness.</p>
<p>D10 Check Lift Stowed Switch Circuit</p> <ul style="list-style-type: none"> • Disconnect the "Lift" harness at the lift adaptor. • Measure the resistance at the lift harness Pin #5 to chassis ground. <p>Is the resistance < 2 ohms?</p>	<p>Results_____</p> <p>Yes Harness is shorted. Contact InterMotive for assistance.</p> <p>No If open circuit, Lift Stowed Switch needs replacement.</p>

PINPOINT TEST E: LEDS PROPERLY ILLUMINATED, BUT LIFT NOT OPERATING

If the lift does not operate with the lift power LED indicator lit:

- there is a problem with the wiring harness to the lift

- there is a problem with the lift

- the Guardian module have an issue.

Estimated Time To Complete: 12 Minutes

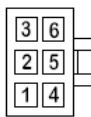
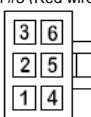
Test Step	Result/Action to Take
<p>E1 Ensure that all connectors are installed correctly</p> <ul style="list-style-type: none"> Carefully inspect module and harness(es) Verify correct harness connector in the correct module plug Refer to schematics in Guardian documentation <p>• Are all harness connectors properly installed into module?</p>	<p>Yes Go to E2</p> <p>Results _____</p> <p>No Review install instructions, reinstall all connectors in their proper position. Test system for normal operation.</p>
<p>E2 Ensure that all wires are in their correct connector cavity</p> <ul style="list-style-type: none"> Carefully inspect all harness connectors Verify that each connector has the correct wires in the correct connector pin cavity Refer to schematics in Guardian documentation for wire colors and pin locations <p>• Are all wires secure, and in their correct connector pin cavity?</p>	<p>Yes Go to E3</p> <p>Results _____</p> <p>No Contact InterMotive for assistance with harness and connectors</p>
<p>E3 Check for vehicle secure.</p> <ul style="list-style-type: none"> Key in the ON position, Park Brake applied, and the transmission in Park. Using a Digital Multimeter, measure the voltage between pin # 2 (Green wire) at the back of the "Lift" connector at the Guardian module, and chassis ground. <p>• Is the measured voltage 11.5 volts or greater?</p>  <p style="text-align: center;">Back of the Lift Connector</p>	<p>Yes Go to E5</p> <p>Results _____</p> <p>No Go to E4</p>
<p>E4 Check for lift power</p> <ul style="list-style-type: none"> Key in the ON position, Park Brake applied, and the transmission in Park. Using Digital Multimeter measure voltage between "Lift" connector Pin #3 (Red wire) and chassis ground. <p>• Is the measured voltage 11.5 volts or greater?</p>  <p style="text-align: center;">Back of the Lift Connector</p>	<p>Results _____</p> <p>Yes Contact InterMotive for assistance with Guardian module.</p> <p>No Check lift power source at the lift adaptor or harness.</p>
<p>E5 Check for lift operation</p> <ul style="list-style-type: none"> Disconnect lift interlock connector from lift Jumper 12 Volt battery power to the lift power wire at the lift connector <p>(Note: you may need to match up which wire on the lift connects to the "lift power" (Red wire from the module) wire on the harness in order to determine which lift wire to power up)</p> <p>• Does the lift operate?</p>	<p>Results _____</p> <p>Yes Repair lift interlock harness from Guardian module to lift connector (Red wire from the module)</p> <p>No Check lift circuits and system. Contact lift manufacturer if still no lift operation.</p>

PINPOINT TEST F: LIFT OPERATES WHEN SAFETY CONDITIONS NOT MET

If the lift operates even though the lift output LED indicator is not lit:

- there is a problem with the wiring harness to the lift.
- there is a problem with the lift.
- the Guardian module may have an issue.

Estimated Time To Complete: 6 Minutes

Test Step	Result/Action to Take
F1 Ensure that all connectors are installed correctly <ul style="list-style-type: none"> • Carefully inspect module and harness(es) • Verify correct harness connector in the correct module plug • Refer to schematics in Guardian documentation 	<p style="text-align: right;">Results_____</p> <p>Yes Go to F2</p> <p>No Review install instructions, reinstall all connectors in their proper position. Test system for normal operation.</p>
<ul style="list-style-type: none"> • Are all harness connectors properly installed into module? 	
Test Step	Result/Action to Take
F2 Ensure that all wires are in their correct connector cavity <ul style="list-style-type: none"> • Carefully inspect all harness connectors • Verify that each connector has the correct wires in the correct connector pin cavity • Refer to schematics in Guardian documentation for wire colors and pin locations 	<p style="text-align: right;">Results_____</p> <p>Yes Go to F3</p> <p>No Contact InterMotive for assistance with harness and connectors</p>
<ul style="list-style-type: none"> • Are all wires secure, and in their correct connector pin cavity? 	
Test Step	Result/Action to Take
F3 Check lift operation <ul style="list-style-type: none"> • Disconnect "Lift" connector from Guardian module and attempt to operate lift 	<p style="text-align: right;">Results_____</p> <p>Yes Check for bypass jumper wires or short to power on lift circuit or at the lift</p> <p>No Contact InterMotive for assistance with Guardian module</p>
<ul style="list-style-type: none"> • Does the lift operate? 	

PINPOINT TEST G: LIFT OPERATES INTERMITTENTLY

Estimated Time To Complete: 6 Minutes

Test Step	Result/Action to Take
G1 Check lift operation <ul style="list-style-type: none"> • Observe LED's when lift won't operate 	<p>Refer to the symptom chart for diagnosis based on the LED display indicators during faulty operation</p>
<ul style="list-style-type: none"> • What does the LED panel display? 	

PINPOINT TEST H: SHIFTER NEVER LOCKS		Estimated Time To Complete: 12 Minutes	
Test Step		Result/Action to Take	
H1 Ensure that all connectors are installed correctly • Carefully inspect module and harness(es) • Verify correct harness connector in the correct module plug • Refer to schematics in Guardian documentation • Are all harness connectors properly installed into module?		Yes Go to H2 No Review install instructions, reinstall all connectors in their proper position. Test system for normal operation.	
H2 Ensure that all wires are in their correct connector cavity • Carefully inspect all harness connectors • Verify that each connector has the correct wires in the correct connector pin cavity • Refer to schematics in Guardian documentation for wire colors and pin locations • Are all wires in their correct connector pin cavity?		Yes Go to H3 No Contact InterMotive for assistance with harness and connectors	
H3 Observe LED display panel • Key in the ON or OFF position. • Perform each function; set park brake, transmission in park, lift not stowed. (Move lift away from it's stowed position.) • Does the Lift Not Stowed Indicator LED illuminate properly?  Reminder: The icons on the display panel should be backlit whenever the ignition key is on and after status indicator LED prove out. The sole purpose of the icons is to identify the status indicator LED's located directly above each icon.		Results _____ Yes - Contact InterMotive for assistance with Guardian module and/or OEM shift lock mechanism. No - Go to D7	
PINPOINT TEST J: CANNOT SHIFT OUT OF PARK		Estimated Time To Complete: 12 Minutes	
Test Step		Result/Action to Take	
J1 Ensure that all connectors are installed correctly • Carefully inspect all harness connectors • Verify that each connector has the correct wires in the correct connector pin cavity • Refer to schematics in Guardian documentation for wire colors and pin locations • Are all wires in their correct connector pin cavity?		Yes Go to J2 No Review install instructions, reinstall all connectors in their proper position. Test system for normal operation.	
J2 Ensure that all wires are in their correct connector cavity • Carefully inspect all harness connectors • Verify that each connector has the correct wires in the correct connector pin cavity • Refer to schematics in Guardian documentation for wire colors and pin locations • Are all wires secure, and in their correct connector pin cavity?		Yes Go to J3 No Contact InterMotive for assistance with harness and connectors	
J3 Remove Guardian Data Link 1 • Disconnect data link 1 connector at module • Turn ON ignition, Release Parking Brake, and Press on Service Brake. • Can you shift out of park?		Results _____ No Contact OEM for shift lock repair. Yes Contact InterMotive for assistance with Guardian module	

PINPOINT TEST K: SOME, but not all, DISPLAY PANEL LEDs DO NOT PROVE OUT PROPERLY

If an LED indicator does not light when the ignition key is initially turned to ON or power is initially applied to the module.

- there is a problem with the LED indicator display and/or circuit.

- the Guardian module may have an issue.

Estimated Time To Complete: 12 Minutes

Test Step	Result/Action to Take
<p>K1 Ensure that all connectors are installed correctly</p> <ul style="list-style-type: none"> Carefully inspect module and harness(es) Verify correct harness connector in the correct module plug Refer to schematics in Guardian documentation <p>• Are all harness connectors properly installed into module?</p>	<p>Results _____</p> <p>Yes Go to K2</p> <p>No Review install instructions, reinstall all connectors in their proper position. Test system for normal operation.</p>
<p>K2 Ensure that all wires are in their correct connector cavity</p> <ul style="list-style-type: none"> Carefully inspect all harness connectors Verify that each connector has the correct wires in the correct connector pin cavity Refer to schematics in Guardian documentation for wire colors and pin locations <p>• Are all wires secure, and in their correct connector pin cavity?</p>	<p>Results _____</p> <p>Yes Go to K3</p> <p>No Contact InterMotive for assistance with harness and connectors</p>
<p>K3 Check LED Drive Circuit</p> <ul style="list-style-type: none"> Back probe the failing pin at the "LED" connector during prove out. Pin #2 if "Vehicle Secure" LED failure. (Red Digital Mutimeter test lead) Pin #6 if "Lift Not Stowed" LED failure. (Red Digital Mutimeter test lead) <p>Black Digital Mutimeter test lead to ground.</p> <p>Note: Prove out lasts about 2 sec. at the beginning, when module is first powered up. To cause this, disconnect, then reconnect the "Data Link 1" connector.</p> <div data-bbox="584 903 714 1060" style="text-align: center;"> <p>"LED" connector receptacle</p> </div> <p>Is voltage less then 2v, but greater then 4v? (Typical 3.1v)</p>	<p>Results _____</p> <p>Yes Contact InterMotive for assistance with LED display panel</p> <p>No Voltage = 5v. Contact InterMotive for assistance with Guardian Module. Voltage = 0v. Open circuit in harness or LED display. Contact InterMotive for assistance with LED harness or LED display panel.</p>