

EcoLock

Vehicle Secured Idle Reduction System

Overview

- Automatically turns the engine off and on when specific conditions are met and the key is out of the ignition
- Configurable to custom conditions
- Helps meet anti-idling regulations
- Simple plug and play connection
- Keeps vehicle secure

Features

- **FUEL SAVINGS:** Cuts idling fuel consumption nearly in half; pays for itself in a short period of time
- **ECO-FRIENDLY:** Reduces CO2 emissions and saves 19 lbs per gallon burned while idling
- Works while the key is removed from the ignition
- Thermostat regulation available to keep interior temperature comfortable for personnel or temperature-sensitive equipment
- For police vehicles, the gun rack and trunk release are disabled

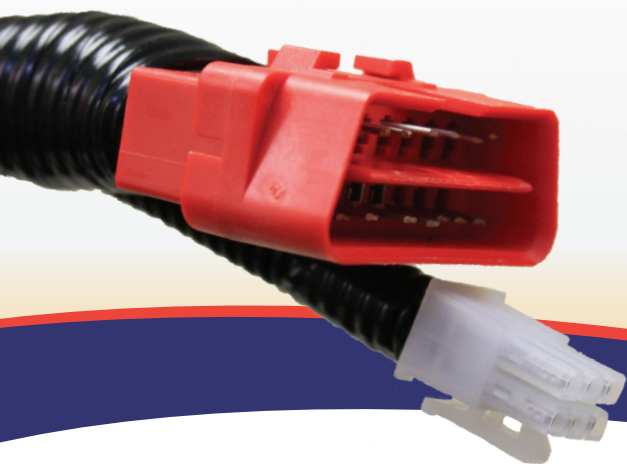

Proudly distributed by

Details

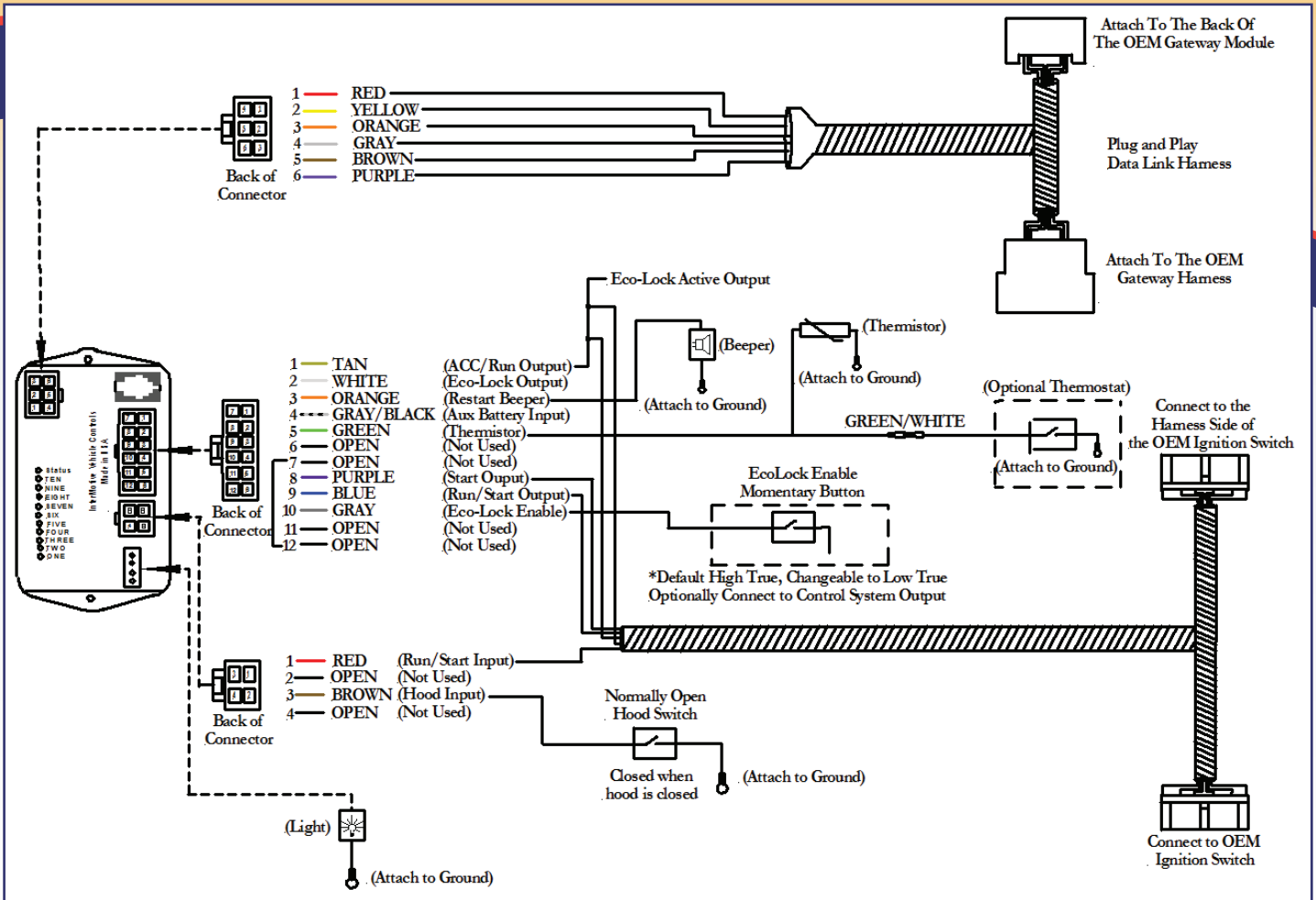

SPECIFICATIONS

Number of Inputs Three active low inputs, one analog input

Number of Outputs Two active high outputs

Current Draw 60-120ma

Quiescent Draw < 2ma (sleep current)

CAN Speed High speed and medium speed

Temperature Range -40°C to 80°C

Dimensions 4" L x 2" W x 1" H